

Design, Operation, and Maintenance Manual for Georgia Digital Faultmeter

Report No. FHWA-GA-91-SP9010

Prepared by

Georgia Department of Transportation
Office of Materials & Research
Forest Park, Georgia



U.S. Department
of Transportation
**Federal Highway
Administration**

June 1991

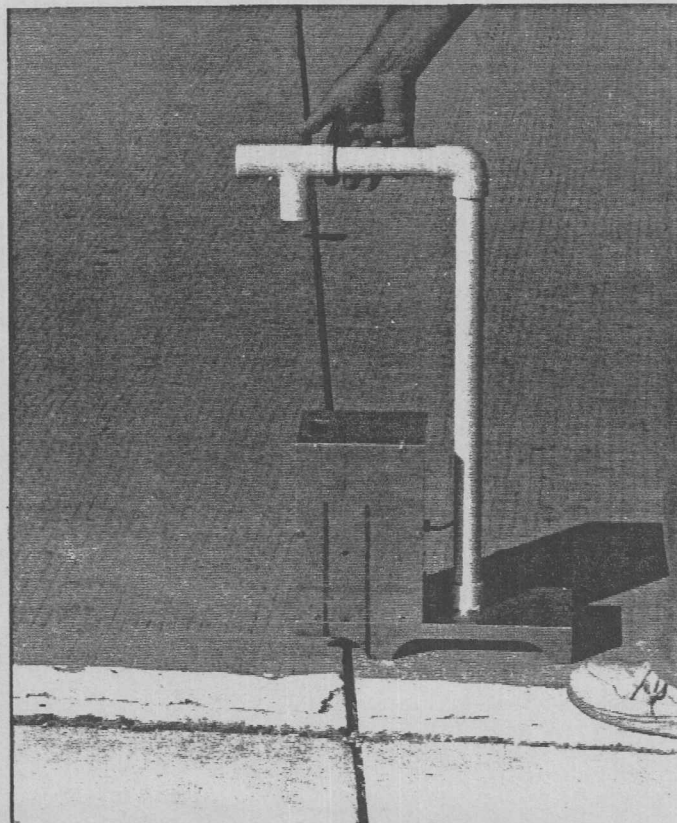

FOREWORD

The Georgia digital faultmeter has been developed for internal use by the Georgia Department of Transportation (Georgia DOT). The Faultmeter is used to measure faulting between slabs that occurs on jointed portland cement concrete pavements. It reads faulting directly in thirty-seconds of an inch, and can be moved without disturbing the reading.

The Design, Operation, and Maintenance Manual describes the faultmeter and its operation. The Manual was one of four products selected for development by the Federal Highway Administration (FHWA) from over 100 proposals in the 1989 Winner Products Program. The Georgia Manual is the first of the four Winner Products to be finalized for distribution.

An early beneficiary of the Georgia faultmeter was the Strategic Highway Research Program (SHRP) Southern Regional Office. The Georgia DOT has fabricated four faultmeters to meet SHRP's specifications.

Sufficient copies of the Manual are being distributed to provide a minimum of two copies to each FHWA regional office, division office, and State highway agency.

Copies for the divisions and States are being distributed directly to the division offices.

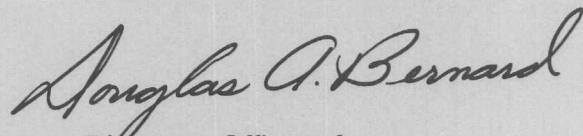

Director, Office of
Technology Applications

NOTICE

This Manual is disseminated under the sponsorship of the Department of Transportation in the interest of information exchange. It does not constitute a standard, specification or regulation.

IMPLEMENTATION PACKAGE
FOR
THE GEORGIA DIGITAL FAULTMETER

DESIGN, OPERATION AND
MAINTENANCE MANUAL

Prepared by:

Jerry Stone
Georgia Department of Transportation
Office of Materials & Research
Forest Park, Georgia

June, 1991

1. Report No. FHWA-GA-91-SP9010	2. Government Accession No.	3. Recipient's Catalog No.	
4. Title and Subtitle Georgia Digital Faultmeter		5. Report Date June, 1991	
		6. Performing Organization Code	
7. Author(s) Jerry Stone		8. Performing Organization Report No. SP 9010	
9. Performing Organization Name and Address Georgia Department of Transportation Office of Materials and Research 15 Kennedy Drive Forest Park, Georgia		10. Work Unit No.	
		11. Contract or Grant No.	
		13. Type of Report and Period Covered Implementation Package	
12. Sponsoring Agency Name and Address Federal Highway Administration 1720 Peachtree Road, N.W., Suite 200 Atlanta, Georgia 30367		14. Sponsoring Agency Code	
		15. Supplementary Notes	
16. Abstract <p>Personnel of the Georgia Department of Transportation, Office of Materials and Research, designed and built electronic digital faultmeters to easily measure concrete joint faulting. The unit reads faulting directly in thirty-seconds of an inch within one second. The reading remains "frozen" in the display allowing the meter to be removed from the road for safety before reading.</p> <p>The objective of this project was to prepare an Implementation Package covering the design, operation and maintenance of the Georgia Digital Faultmeter. Detailed plans, parts lists and cost estimates are included in this Implementation Package.</p>			
17. Key Words Concrete pavement, concrete joints, faulting, Faultmeter		18. Distribution Statement	
19. Security Classif. (of this report) Unclassified	20. Security Classif. (of this page) Unclassified	21. No. of Pages	22. Price

TABLE OF CONTENTS

	<u>Page</u>
List of Figures.....	iv
List of Tables.....	vi
I. INTRODUCTION.....	1
II. DESCRIPTION OF FAULTMETER.....	2
III. OPERATING THE FAULTMETER.....	4
IV. MAINTENANCE.....	6
V. INITIAL CALIBRATION OF FAULTMETER.....	7
VI. COST ESTIMATE.....	8
VII. ELECTRONIC DESIGN, PLANS AND CONSTRUCTION.....	8
VIII. MECHANICAL DESIGN, PLANS AND CONSTRUCTION.....	18
IX. MODIFICATIONS FOR SHRP.....	33

LIST OF FIGURES

<u>Figure</u>		<u>Page</u>
1.	The Ga. DOT Digital Faultmeter.....	1
2.	Close-up of Faultmeter Digital Display.....	2
3.	Bottom of Faultmeter Base.....	3
4.	Operating the Faultmeter.....	4
5.	Faultmeter Sitting on Calibration Stand.....	6
6.	Back of DVM Case.....	9
7.	Front of DVM Case.....	10
8.	DVM Top View - Shows Switch Opened Up.....	10
9.	DVM Top View - Shows Jumpers to Bypass Switch.....	11
10.	DVM Bottom View - Shows Wires to Connect to Control Board...	12
11.	Schematic Diagram for Control P.C. Board.....	13
12.	Component Layout of Control P.C. Board.....	16
13.	Photo of Component Side of Control P.C. Board.....	17
14.	Photo of Foil Side of Control P.C. Board.....	17
15.	Top View of Base Plate Showing Measuring Rod, LVDT and Holder Assemblies.....	18
16.	Side View Showing Inside of Box.....	19
17.	Side View Showing P.C. Mounted to Side of Box.....	20
18.	Faultmeter Calibration Stand.....	20
19.	Drawing A-FM, Overall View of Faultmeter.....	23
20.	Drawing B-FM, Side View of Base Plate.....	24
21.	Drawing C-FM, Top View of Base Plate.....	25
22.	Drawing D-FM, Holder for LVDT.....	26

LIST OF FIGURES (Continued)

<u>Figure</u>		<u>Page</u>
23.	Drawing E-FM, Holder for Measuring Rod.....	27
24.	Drawing F-FM, Stainless Steel Measuring Rod.....	28
25.	Drawing G-FM, Faultmeter Handle.....	29
26.	Drawing H-FM, Top & Bottom View of Electronics Cabinet.....	31
27.	Drawing I-FM, Back & Side View of Electronics Cabinet.....	32
28.	Drawing J-FM, Calibration Stand for Faultmeter.....	34

LIST OF TABLES

<u>Table</u>	<u>Page</u>
1. Parts List - Electronic.....	14
2. Parts List - Mechanical.....	21

THE GEORGIA DIGITAL FAULTMETER

I. INTRODUCTION

The electronic digital faultmeter shown in Figure 1 was designed to simplify measuring concrete joint faulting. This meter was designed, developed and built by The Office of Materials and Research personnel in 1987.

The purpose of this manual is to describe the Georgia Digital Faultmeter in sufficient detail so that any interested party can build their own. The design, operation and maintenance of the meter will be covered. Plans, parts list and cost estimates are also included.

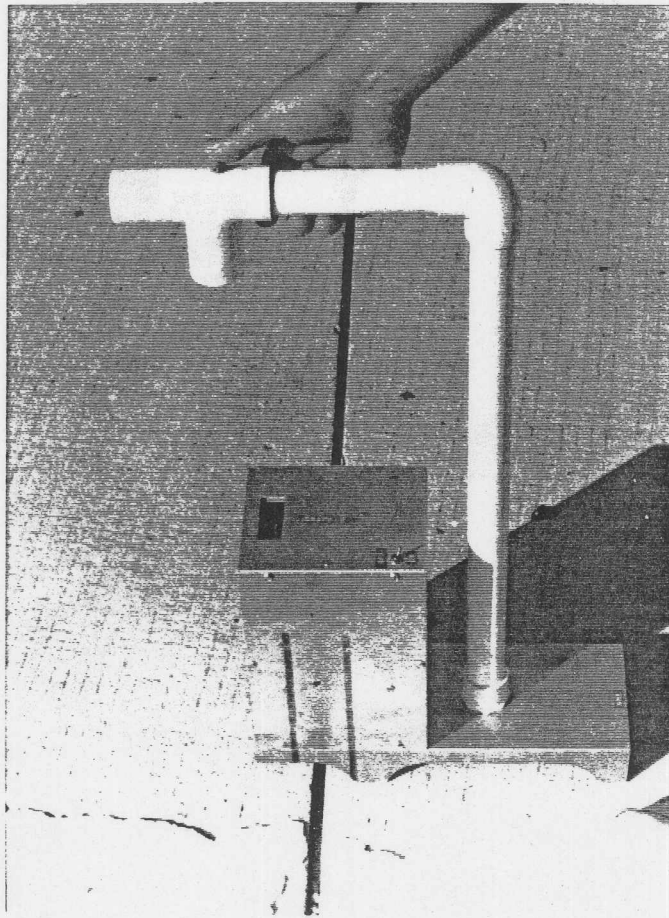

Figure 1. The Georgia DOT Digital Faultmeter

II. DESCRIPTION OF FAULTMETER

The Georgia Digital Faultmeter is very light and easy to use. The unit weighs approximately 7 pounds and supplies a digital readout with the push of a button located on the carrying handle. It reads out directly in 32nds of an inch and shows whether the reading is positive or negative. The unit reads out in 1 second and freezes the reading in the display so it can be removed from the road before reading for a safer operation. Figure 2 shows a close-up of the meter showing the digital display. Note the arrow showing traffic direction.

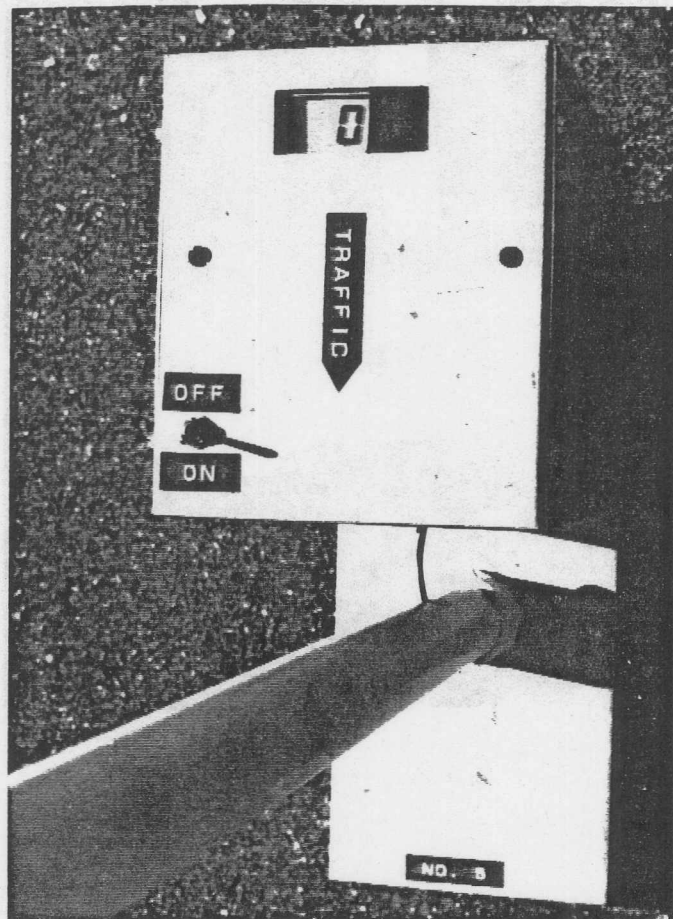

Figure 2. Close-up of Faultmeter Digital Display

Figure 3 shows a view of the bottom of the faultmeter base. The legs of the base set on the slab on the leave side of the joint. The measuring probe,

shown to the right side of the picture, contacts the slab on the approach. Movement of this probe is transmitted to a LVDT to measure joint faulting. The joint must be centered between the guidelines shown on the side of the meter.

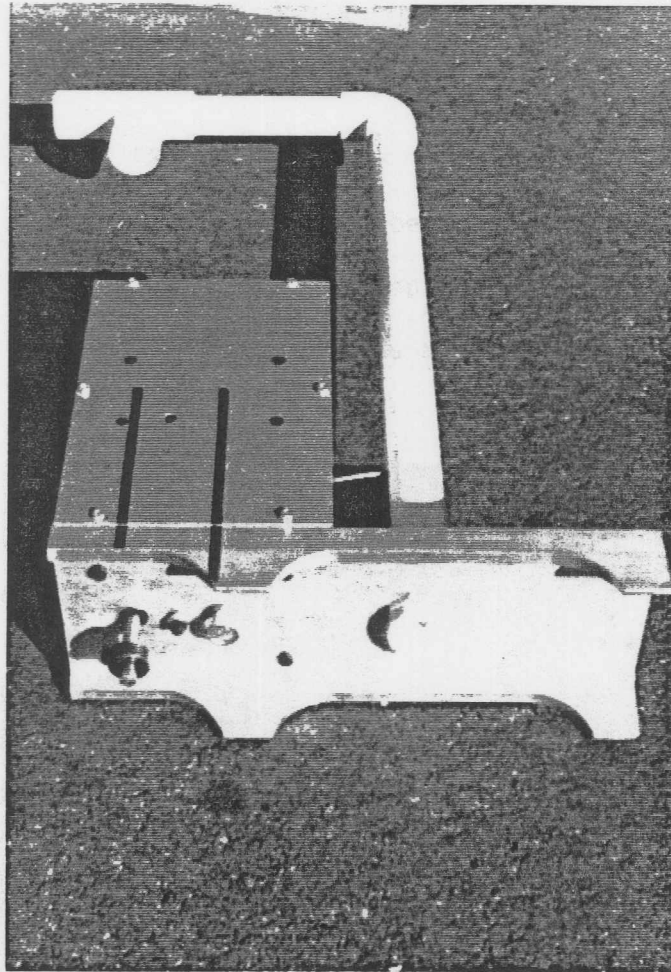

Figure 3. Bottom of Faultmeter Base

Any slab which is lower on the leave side of the joint will register as a positive faulting number. If the slab leaving the joint is higher, the meter gives a minus reading. The Georgia faulting index (F.I.) is the total faulting for 5 consecutive joints in 32nds of an inch.

The faulting of every eighth joint is measured to obtain a representative sample for each mile of concrete. The F.I. is simply the total of all the meter readings times 5 divided by the number of readings. When the meter readings are totalled, the minus readings are ignored. For example, a faulting of 15 indicates an average faulting for each joint of $3/32$ inches.

III. OPERATING THE FAULTMETER

Figure 4 shows the digital faultmeter being used to measure concrete joint faulting. This section gives step by step operating instructions. Complete mechanical and electronic plans, parts lists and cost estimates are given later in this report.



Figure 4. Operating the Faultmeter

To operate the unit: (1) Turn the power switch on. The switch should be left on as long as testing is in progress. Do not turn off between tests. The unit should be turned off at lunch time to conserve batteries. Be sure to turn off at end of the day. (2) Grip the handle of the meter with the thumb resting lightly on the test button. Use the right hand when testing the outside lane and the left hand for the inside lane. This allows the operator to stand safely on the shoulder facing traffic while making the test. There is an arrow on the meter showing traffic direction. (3) Set the meter on the leave side of the joint. A probe contacts the slab on the approach side. The joint must be centered between the two marks on each side of the meter. (4) Push, then instantly release the test button. A one second tone will sound. (5) As soon as the tone stops, lift the meter and move away from the pavement. The meter will remain "frozen" until the next reading is taken. This feature allows the operator to move away from traffic before the meter is read.

Although the meter is very stable, it should be checked at the beginning of each day and after lunch to assure correct readings. Set the meter on the cal. stand shown in Figure 5 with the front end lined up with the cal. 12 mark. In this position the probe rests on a $\frac{3}{8}$ inch block. As $\frac{3}{8}$ inch = $\frac{12}{32}$, a reading of 12 is obtained. Set the meter to line up with the zero mark. The meter should read zero.

So long as the zero and 12 readings are obtained, the unit is working properly. If not, discontinue testing and set the calibration as described in Section V. Be sure to check for any electronic malfunction before adjusting the calibration and zero controls. Extremely low batteries could also cause an erroneous reading.

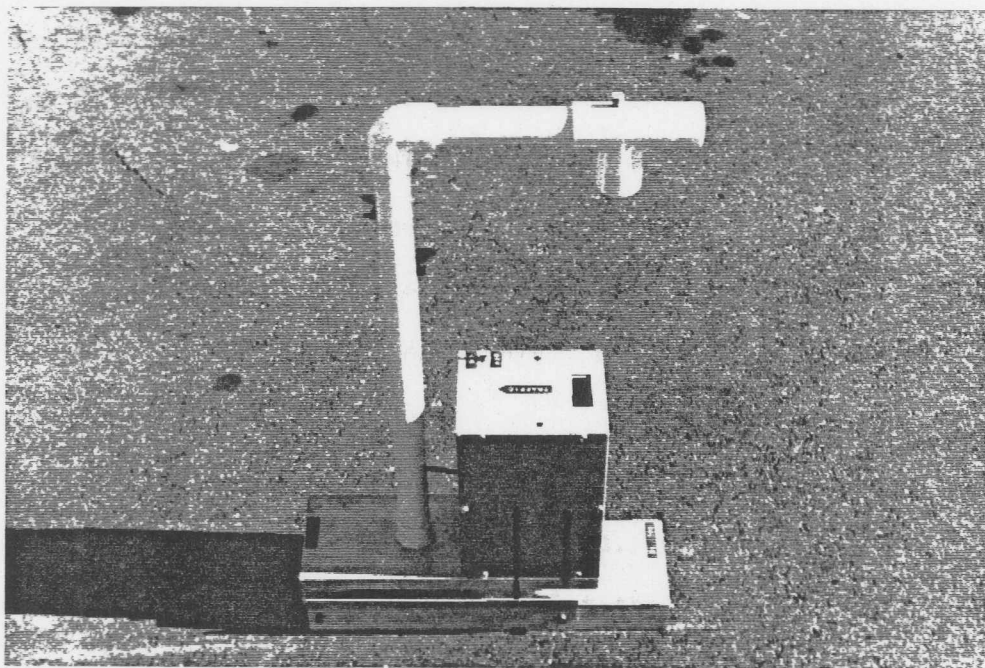

Figure 5. Faultmeter Sitting on Calibration Stand

IV. MAINTENANCE

No routine maintenance of the faultmeter is normally required. Should the batteries need replacing, the 1 second continuous tone will be followed by a 3 second pulsating tone and "LO BATT" will show in the upper left corner of the display. The readings will still be accurate but the batteries should be replaced within a day or so.

If the measuring rod does not move freely, the readings will be in error. This should not be a problem as the rod is made of stainless steel and will not rust. If the rod should get coated with road film and dust, it may be cleaned with a damp cloth. Do not clean with penetrating oil or any products that will leave an oily residue, as this will cause dust to adhere to the rod. If the rod "clicks" when the meter is lifted from the pavement, this is a good indication it is sliding freely.

V. INITIAL CALIBRATION OF FAULTMETER

After the initial calibration, the faultmeter is inherently stable and will not vary from day to day. Of course the meter should be checked daily as described in Section III. Should the calibration ever change, extremely low battery or an electronic problem would normally be indicated. The following set-up procedure should be needed only for initial calibration or after correcting an electronic malfunction.

Zero and calibration controls are provided on the control P.C. board. Both are 20 turn potentiometers. Before beginning, turn each approx. 10 turns from either end to center the adjustment. Set the faultmeter on the calibration stand in the zero position. Hold the test button down for the following steps.

Loosen the bolt that clamps the LVDT in its holder. Slide the LVDT up or down to obtain an approximate "0" reading. Retighten the LVDT clamp. All other adjustments will be made with the zero and calibration potentiometers.

Adjust the zero control to exactly zero. The easiest way is to slowly turn the control until the minus (-) sign in the display flickers on and off. Next move the faultmeter to the calibrate position on the stand. For a 3/8" block and a meter reading in 32nds, a reading of 12 (12/32") should be obtained.

The easiest way is to slowly turn the control up to the next higher number (13 in this case) and down to the next to the next lower number (11 in this case). Turn the control exactly half way between these limits to be in the center of the desired number (12 in this instance).

Re-check the fault meter on the calibration stand in both the zero and calibrate positions. Touch up either control slightly if necessary. It is a good idea to put a drop of fingernail polish or other adhesive on the adjusting screw of the controls after setting them. This keeps the controls from

accidentally moving because of vibration. Try to leave the screwdriver slot open in case they should ever have to be adjusted again.

VI. COST ESTIMATE

The cost of the parts to build the Georgia Faultmeter should be between \$500 - \$700, depending on how many are built. The biggest problem when building only a few units is with the aluminum and stainless steel stock. These must normally be purchased in 12 to 25 ft. minimums.

The minimum purchase of each size costs approximately \$275, but furnished enough material for at least 7 units. Thus the cost per unit for metal stock could vary from \$40 up to \$275.

The LVDT is the single most expensive item. The price is currently \$300 for a $\pm 5/8$ " stroke and \$320 for a ± 1 " stroke. The DVM purchased from Sears cost \$40. The box used to house the electronics costs \$20 - \$25.

All other miscellaneous parts should total less than \$100. This total includes electronic parts, clampite collars, threaded 1/2" stock, PVC pipe, PVC fittings and PVC glue. The clampite collars are available from bearing supply warehouses. The threaded 1/2" stock was obtained from a local hardware.

VII. ELECTRONIC DESIGN, PLANS AND CONSTRUCTION

The electronic measuring circuit was designed around a commercial DVM (digital volt meter) using a LVDT (linear variable differential transformer) for the measuring device. An LVDT is a very rugged device with no mechanical parts to wear out. It was cheaper and much simpler to use the commercial DVM than to build a readout.

A simple control circuit was then built to perform various "housekeeping"

functions for the DVM. The circuit supplies the regulated voltage for the LVDT, scales the LVDT output voltage, provides the low battery alert, provides the one second "test" tone and "freezes" the reading in the DVM display. Plans and a parts list for this circuit are given later in this section.

First, the modifications to the DVM will be covered. The DVM chosen was a Sears #82416. It cost only \$40 and has a data hold feature. First, take out 2 screws and remove the back. Cut a slot in the back as shown in Fig. 6. This allows access for the wires connecting the DVM to the control printed circuit (P.C.) board.

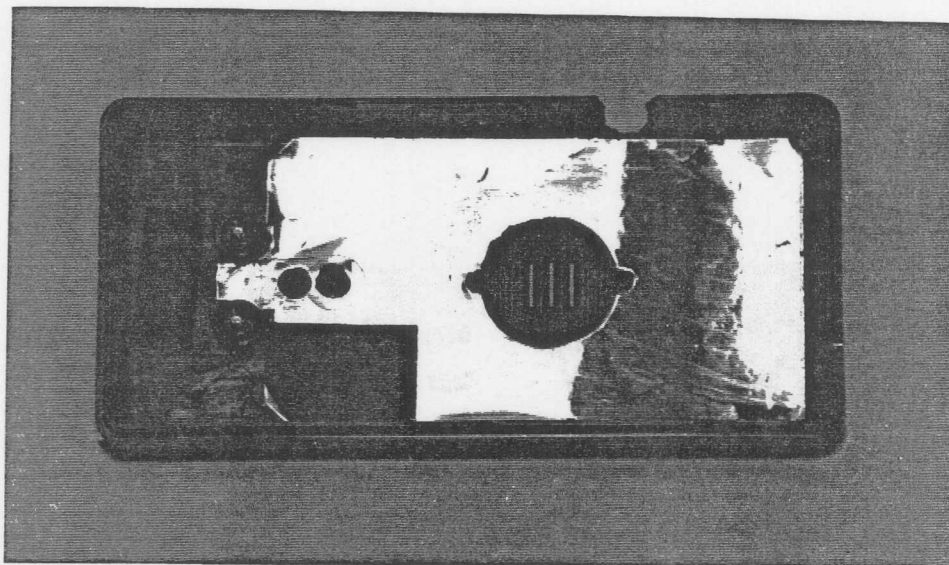

Figure 6. Back of DVM Case

Remove one screw to take the p.c. board off the front part of the case. The front of the case is shown in Figure 7. Remove the clip and discard the knob assembly.

Take out the 4 screws holding the switch to the main p.c. board. Be sure to take out the screws on the back side of the board. Lift up the small p.c. board and expose the switch assembly as shown in Fig. 8. Unsolder the 6 wire

connection cable at the main board. Discard the small board, cable and disc switch assembly.

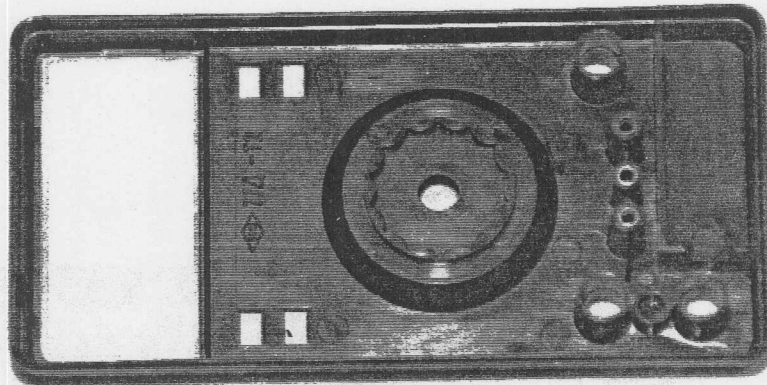

Figure 7. Front of DVM Case

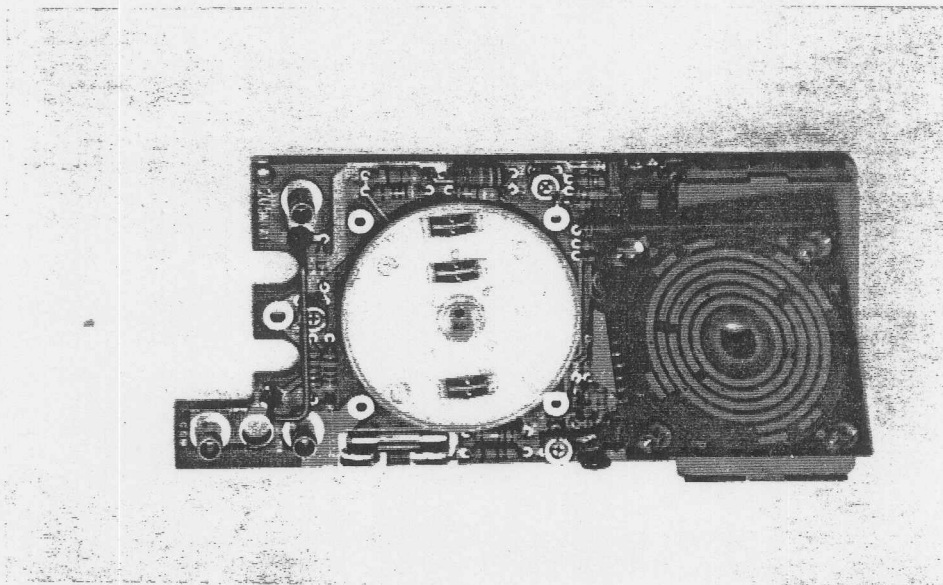

Figure 8. DVM Top View - Shows Switch Opened Up

Originally, the switch that came with the meter was used. The switch was simply left on the 2000 MV (or 2 volt) range. However, after a year or two without changing ranges, the switch became erratic. Normally the switch is being periodically rotated, which helps keep the contacts cleaned. The purpose

in discarding the original switch is to make permanent soldered jumpers to eliminate this potential problem.

Fig. 9 shows the jumpers used to bypass the original switch. Note that 2 jumpers were made directly between the contact rings on the p.c. board used by the original switch. Two short wire jumpers were also required. All 4 jumpers are marked on Fig. 9.

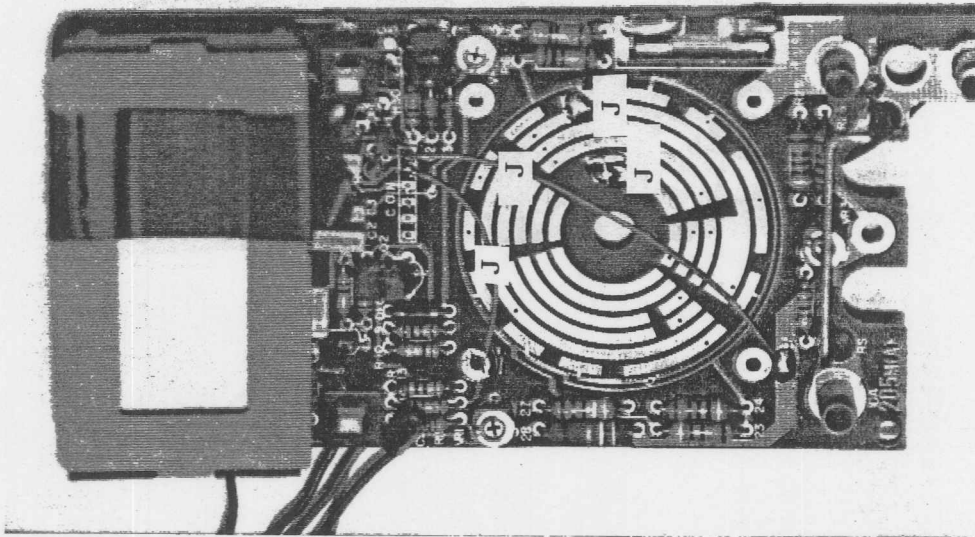

Figure 9. DVM Top View - Shows Jumpers to Bypass Switch

Several connections must be made from the DVM p.c. board to the control p.c. board. First, unsolder the 9 volt battery plug as battery voltage will be supplied from the control board. Make the 5 connections to the back of the board as shown in Fig. 10. These wires, marked (A) through (E), connect to corresponding points on the control p.c. drawing.

Put tape over the right 2 digits to block them out. Only the left hand digit and the overrange are used. This gives a maximum reading of ± 19 . As soon as the reading goes to ± 20 , the display digit blanks to show that the LVDT

range has been exceeded. This assures that an erroneous reading can not be obtained.

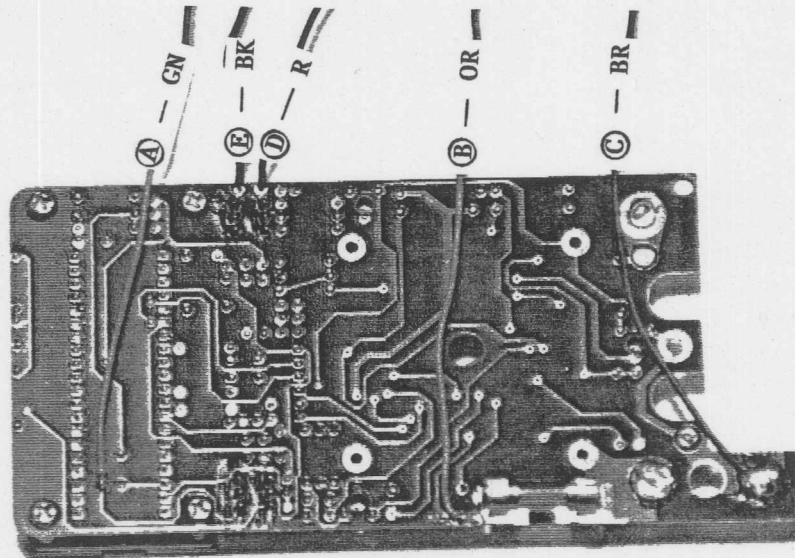

Figure 10. DVM Bottom View - Shows Wires to Connect to Control Board

Remove the power and hold buttons on the DVM as these functions will be handled by the control board. The DVM power switch must be left in the on position and the hold switch in the off position. Reassemble the DVM in its case.

Figure 11 shows a schematic for the control board and Table 1 contains a parts list. This circuit provides regulated power for the LVDT, provides the audible test tone, "freezes" the faulting reading in the display, provides an audible low battery tone and provides a means of adjusting the zero and calibration readings. A simplified description of the operation of the circuit follows.

When the test button is pushed, the output of IC1-b goes low, disabling the

GEORGIA FAULTMETER
 Georgia Department of Transportation
 Office of Materials and Research

Designed by: Jerry Stone 11/4/87 Rev. 10/6/88

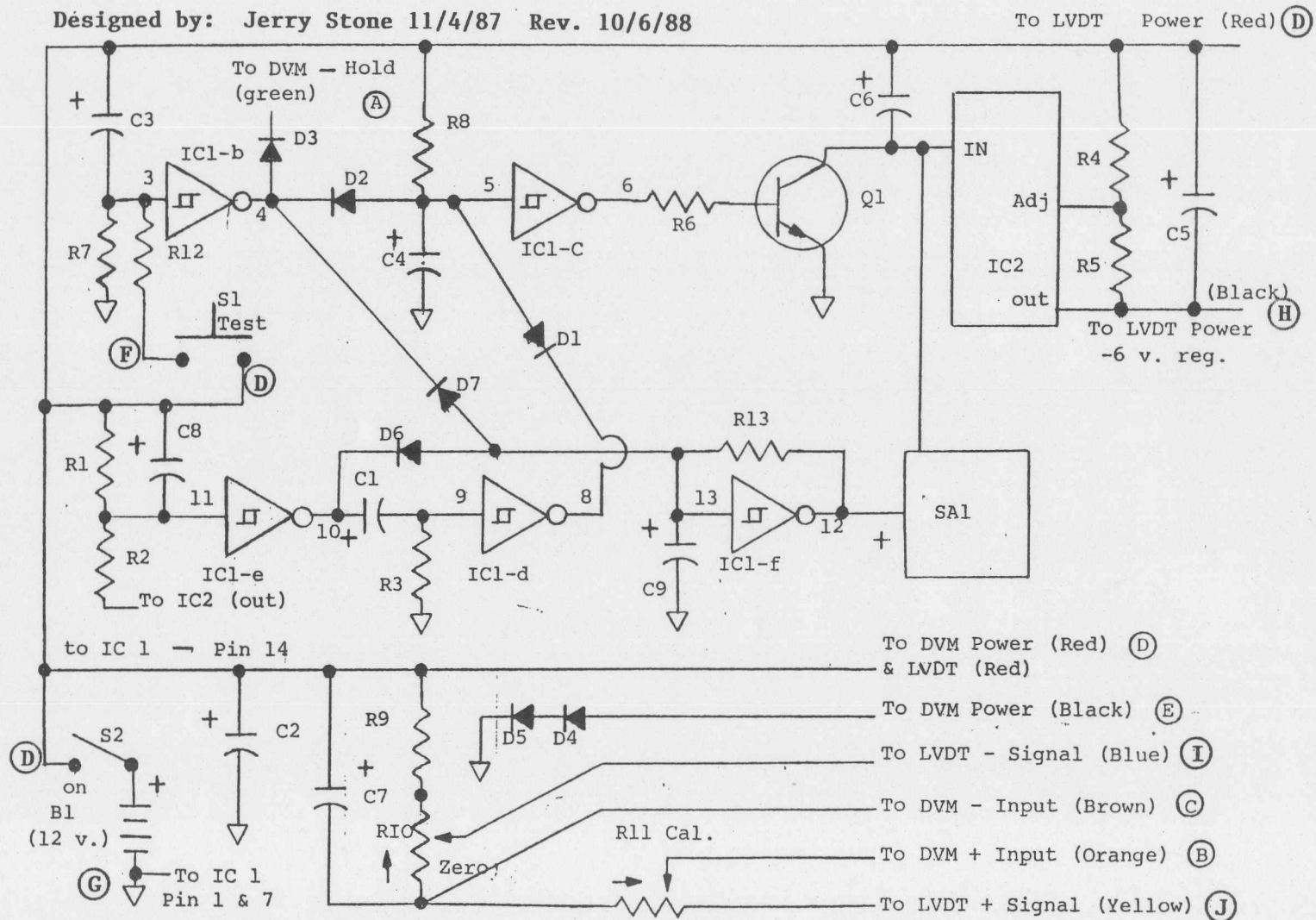

Figure 11. Schematic Diagram For Control P.C. Board

TABLE 1. PARTS LIST - ELECTRONIC

B1 = 12 V. battery - 8 "AA" in battery holder
C1,2,7 = 10 mfd @ 16 V. tantulum capacitor
C3-5,8 = 1 mfd @ 16 V. tantulum capacitor
C6,9 = 0.1 mfd @ 16 V. tantulum capacitor
D1-7 = IN914 diode
DVM = Sears #82416 DVM with data hold
IC1 - Motorola MC14584BCP hex Schmitt trigger
IC2 = LM337T or RCA SK9216/957 negative voltage regulator
LVDT = G.L. Collins SS-105 (5/8") or SS-107 (1") for SHRP - (213) 531-6500
Q1 = Motorola MPS 5172 transistor
R1,8 = 100K, 1/4 W. resistor
R2 = 24K - nominal - adj. low battery warning
R3 = 390K, 1/4 W. resistor
R4 = 430 ohm, 1/4 W. resistor
R5 = 120 ohm, 1/4 W. resistor
R6 = 3K, 1/4 W. resistor
R7 = 1.2 meg, 1/4 W. resistor
R9,12 = 10K, 1/4 W. resistor
R10 = 10K - 20 turn pot - pc mount (zero)
R11 = 2.0 meg - 20 turn pot - pc mount (cal)
R13 = 4.7 meg, 1/4 W. resistor
S1 = SPST Pushbutton Switch (test)
S2 = SPST Toggle Switch (off-on)
SA1 = Sonalert - Radio Shack #273-065
- Radio Shack #276-168 universal p.c. board
- Bud AU-1040 box or CU-3011-A for SHRP

DVM data hold. IC1-C input goes low and output goes high. This causes Q1 to conduct applying power to the LVDT through the voltage regulator IC2. This also causes the sonalert (SA1) to produce the "test" tone. One second after the "test" button is released the output of IC1-b goes high causing the reading to be "frozen" in the display. R8 and C4 cause the LVDT to be powered up for an additional 0.1 sec to be sure the reading is properly stored before power is shut off.

When battery voltage drops to approximately 8.4 volts, "LO BATT" shows in the display. When battery voltage falls to approximately 8 volts, the divider consisting of R2 and R1 causes the input of IC1-e to go low and the output high. This causes the output of IC1-d to go low for 4 seconds (3 seconds longer than the normal 1 second test). R2 can be varied to adjust the low battery voltage if necessary. IC1-f is wired as an oscillator which can run only when IC1 pins 10 and 4 are both high. This produces the pulsing tone which signifies low battery voltage.

The DVM is also powered from the same battery supply. R10 provides an electrical zero adjustment utilizing a regulated voltage supply of approximately 2.9 volts built into the DVM. R11 is used to adjust the meter calibration to the correct value.

When the Georgia Digital Faultmeters were built for each District, time was of the essence. As the control circuit was fairly simple, it was simply wired on a Radio-Shack #276-168 universal p.c. board. This saved the lead time required to design a p.c. board, draw up the art work, make negatives, etch the boards, drill the board and de-bug a prototype board. A drawing of the component side of the p.c. board is shown in Fig. 12. Figure 13 is a photo of the component side and Figure 14 is a photo of the foil side of the p.c. board.

GEORGIA FAULTMETER
 Georgia Department of Transportation
 Office of Materials and Research

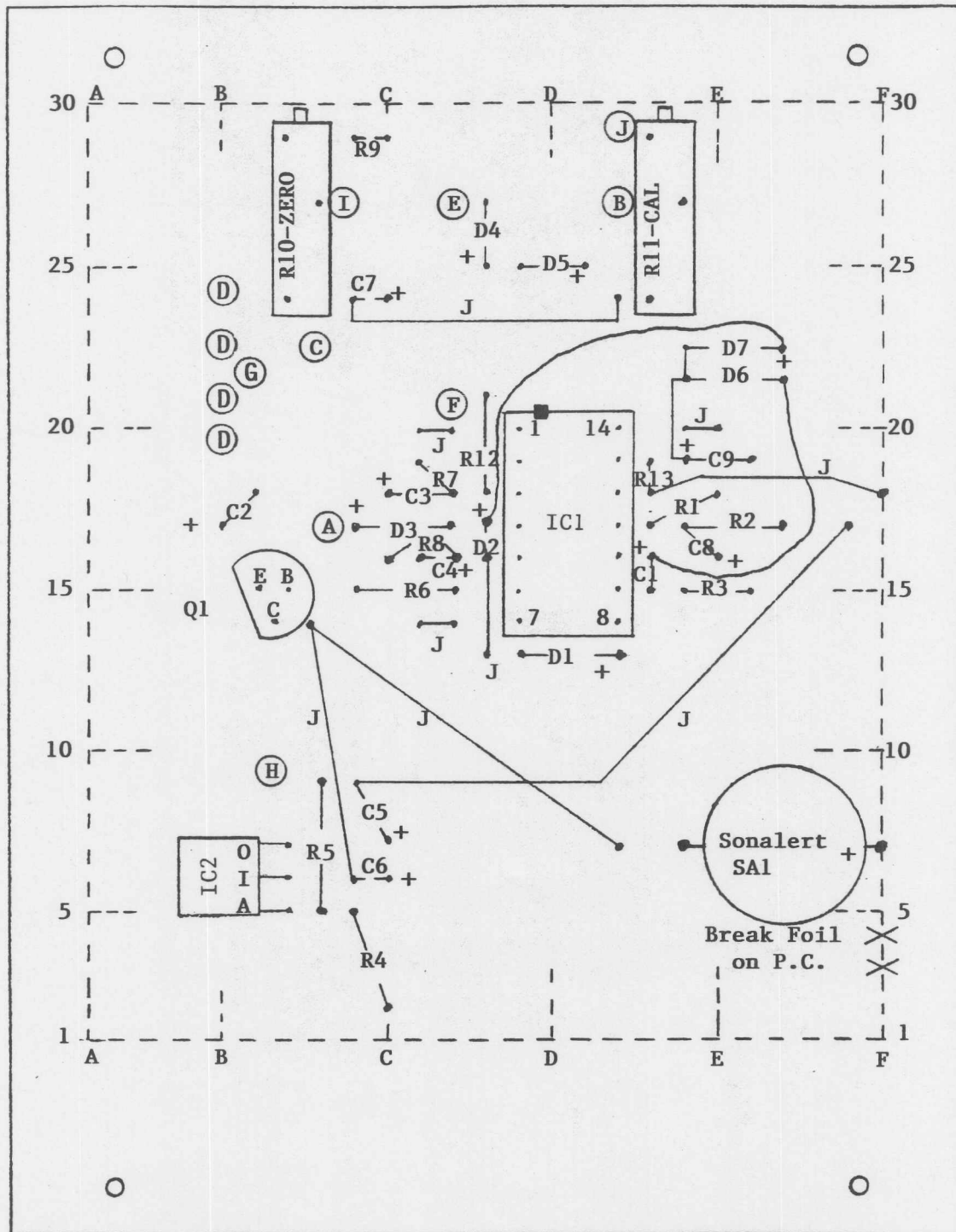

Note: Component side of Radio-Shack 276-168 P.C. Board

Figure 12. Component Layout of Control P.C. Board

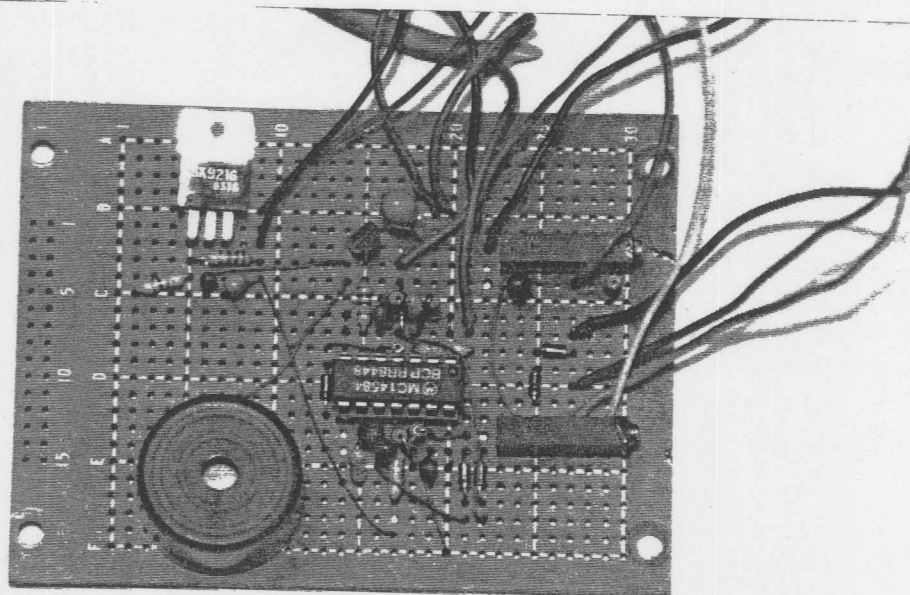

Figure 13. Photo of Component Side of Control P.C. Board

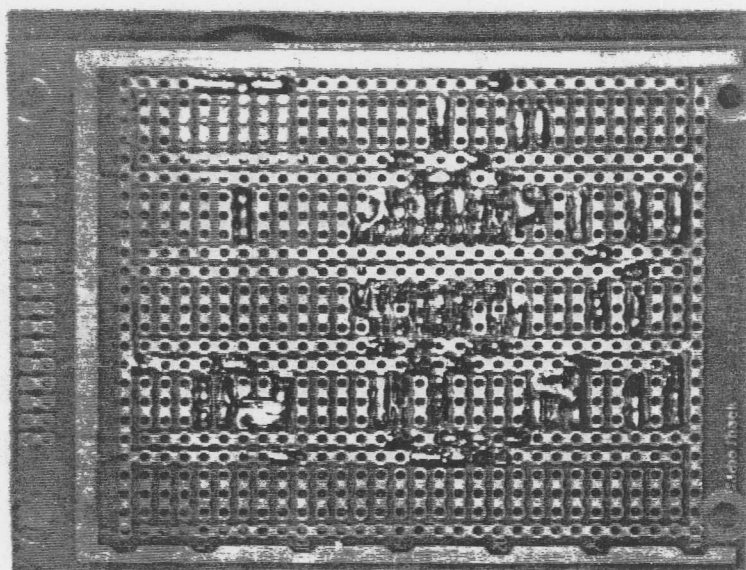

Fig. 14. Photo of Foil Side of Control P.C. Board

VIII. MECHANICAL DESIGN, PLANS AND CONSTRUCTION

Almost any shop should be able to fabricate the Georgia Faultmeter. The only machining required is milling out the sides on the aluminum channel used for the base to form the legs for the unit. The rest of the work can be accomplished using only a saw and a drill press. Complete drawings, as well as several photos, included in this section should assist in fabrication of the meter.

Figure 15 is a photo of the top of the base plate. The stainless steel measuring rod, the LVDT and the holder assemblies are shown assembled to the base. Detailed drawings of the base and these assemblies are included and will be discussed later in this section.

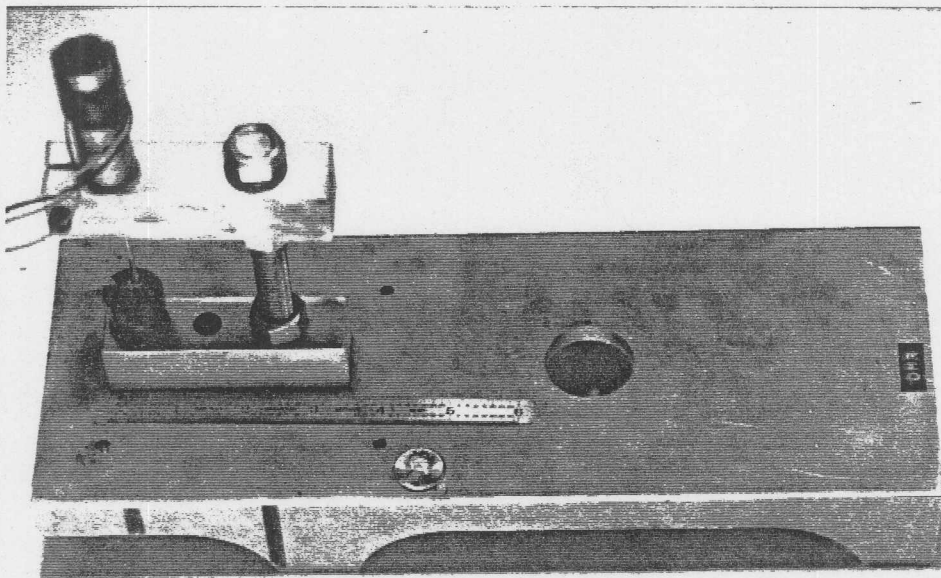

Figure 15. Top View of Base Plate Showing Measuring Rod, LVDT and Holder Assemblies

Figure 16 shows the inside of the electronics box. The LVDT and associated

assemblies can be seen. Notice also the battery pack mounted to the back of the box. Figure 17 shows the other side of the electronics box. Notice that the printed circuit board is mounted directly to this side.

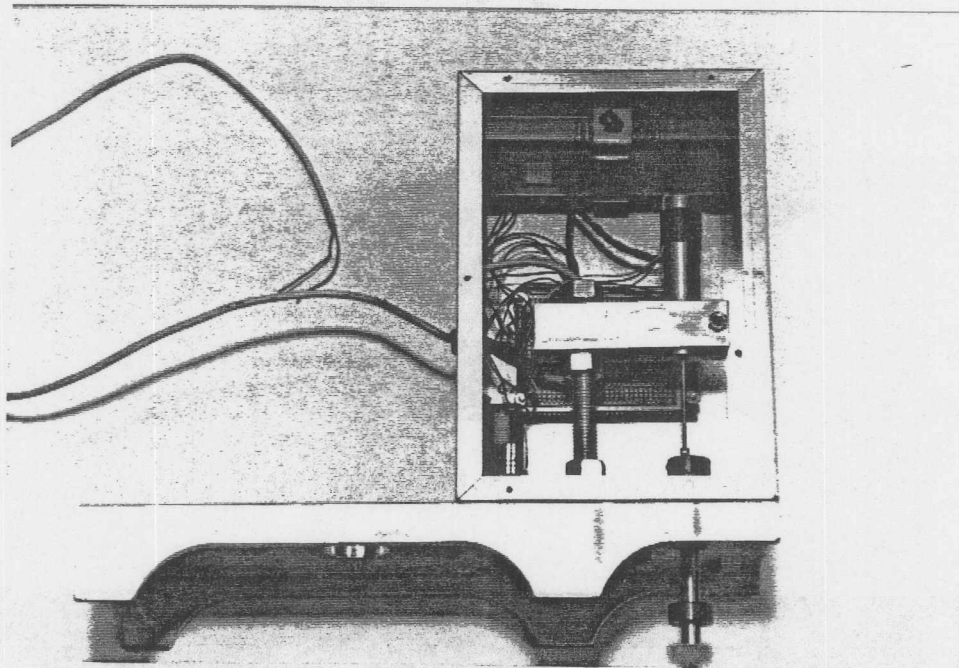

Figure 16. Side View Showing Inside of Box

Figure 18 shows the Faultmeter calibration stand. This is simply another piece of 5" aluminum channel to which a 3/8" thick piece of aluminum has been fastened. When the Faultmeter is positioned so that the measuring rod rests on the 3/8" thick plate, a reading of 12 ($3/8" = 12/32$) is obtained. When the unit is positioned so the rod rests on the top surface of the channel, a reading of zero is obtained. The side rails simply keep the meter from sliding off of the calibration plate.

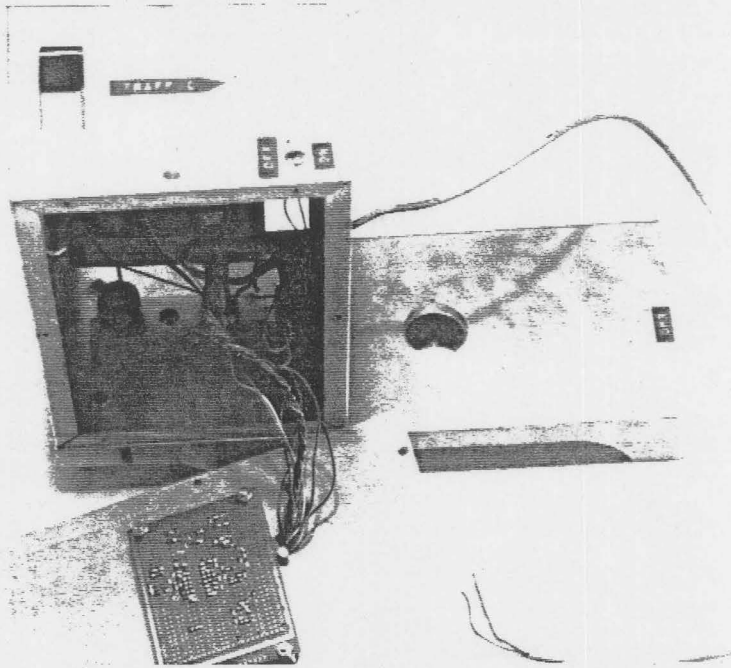

Figure 17. Side View Showing P.C. Mounted To Side of Box

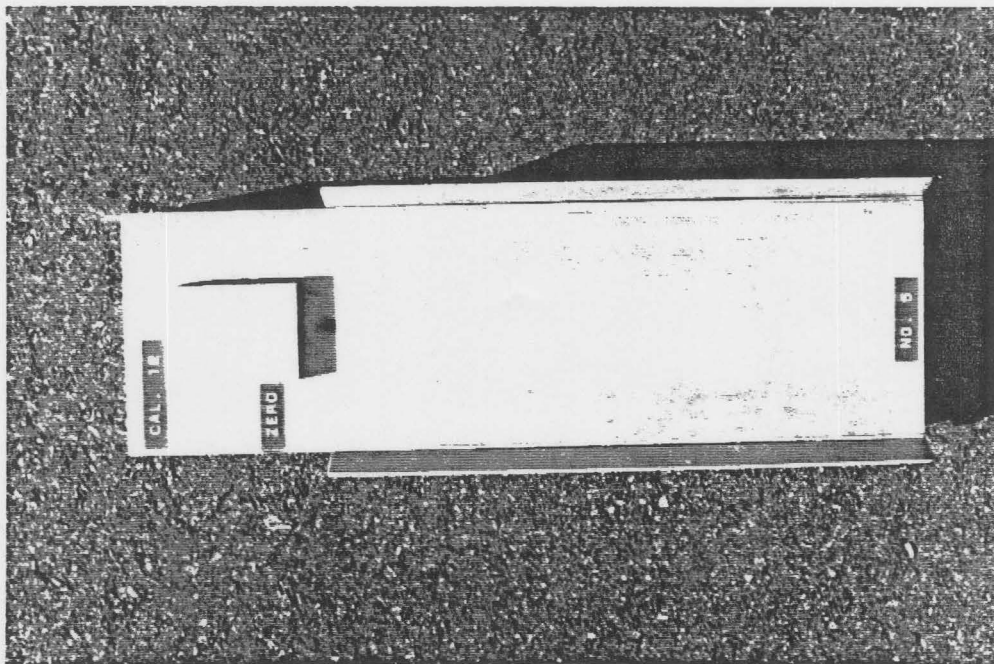

Figure 18. Faultmeter Calibration Stand

Table 2 gives a parts list for the Faultmeter mechanical components. Quantities shown are approximate. A cost estimate for the complete unit is shown in Section VI.

TABLE 2. PARTS LIST - MECHANICAL

<u>DESCRIPTION</u>	<u>QUANTITY</u>
5" Aluminum channel - 0.325" web thickness and 1.885 Flange width	30"
3/8" Stainless steel rod	4"
1" square aluminum bar	8"
Threaded 1/2" rod	7"
2" x 5/64" Aluminum	3'
Holo-Krome/Allen 3/8" Clamptite Collars # 15010	2
2" x 3/8" Aluminum Stock	2"
1" PVC pipe-Schedule 40	3'
1" PVC Female Adapter - Schedule 40	1
1" PVC Male Adapter - Schedule 40	1
1" PVC 90° elbow - Schedule 40	1
1" PVC "T" - Schedule 40	1
1" PVC Caps - Schedule 40	2

The LVDT and the electronics enclosure are shown under the electronics list. Miscellaneous hardware such as the spacer and pin for the handle; nuts, bolts, the homemade "Z" clamps and PVC glue will also be required. The aluminum and stainless steel were obtained from a metal supplier, the clamptite collars from a bearing supply and the other parts from a hardware store.

Figures 19 through 28 consist of drawings A-FM through J-FM which show mechanical construction for the unit. Figure 19 shows an overall view of the base plate. The LVDT, measuring rod and holders are shown. Notice that a clamping collar is used toward the bottom and also at the top of the measuring rod to keep it from falling out. The picture in Figure 15 also shows these assemblies. The PVC pipe carrying handle also attaches to the base.

Figure 20 shows a side view of the base plate and Figure 21 shows the top view. The base is made from 5" aluminum channel with a 0.325" web thickness and 1.885 flange width. The flange is milled out to form the legs the unit rests on and to form the nose through which the measuring rod extends. Notice the small hole next to the hole for the carrying handle. This is simply so a pin can be driven through this hole into a guide hole in the PVC handle to keep it from rotating.

Figures 22 and 23 show the holders for the LVDT and measuring rod. Both are made from 1" square aluminum stock. Notice that the LVDT holder is slotted to allow clamping the LVDT securely in place. The measuring rod holder bolts directly to the base as shown in Figure 19.

Figure 24 shows the measuring rod. It is made from 3/8" stainless steel rod. This is to assure that the rod does not rust and bind in its guide hole. Notice that clamping collars are used toward the bottom and top of the rod. These are simply to keep it from falling out of its guide hole. Of course, the collars are placed on the rod after it is installed in the completed unit.

Figure 25 shows the carrying handle. The handle is made from 1" Schedule 40 PVC pipe and fittings. PVC was chosen because: (1) it is economical, (2) it is easy to work with and requires no special tools, (3) it is not as cold on the hands as metal when testing on a cold day, (4) a wire can be passed inside the

GEORGIA FAULTMETER
 Georgia Department of Transportation
 Office of Materials and Research

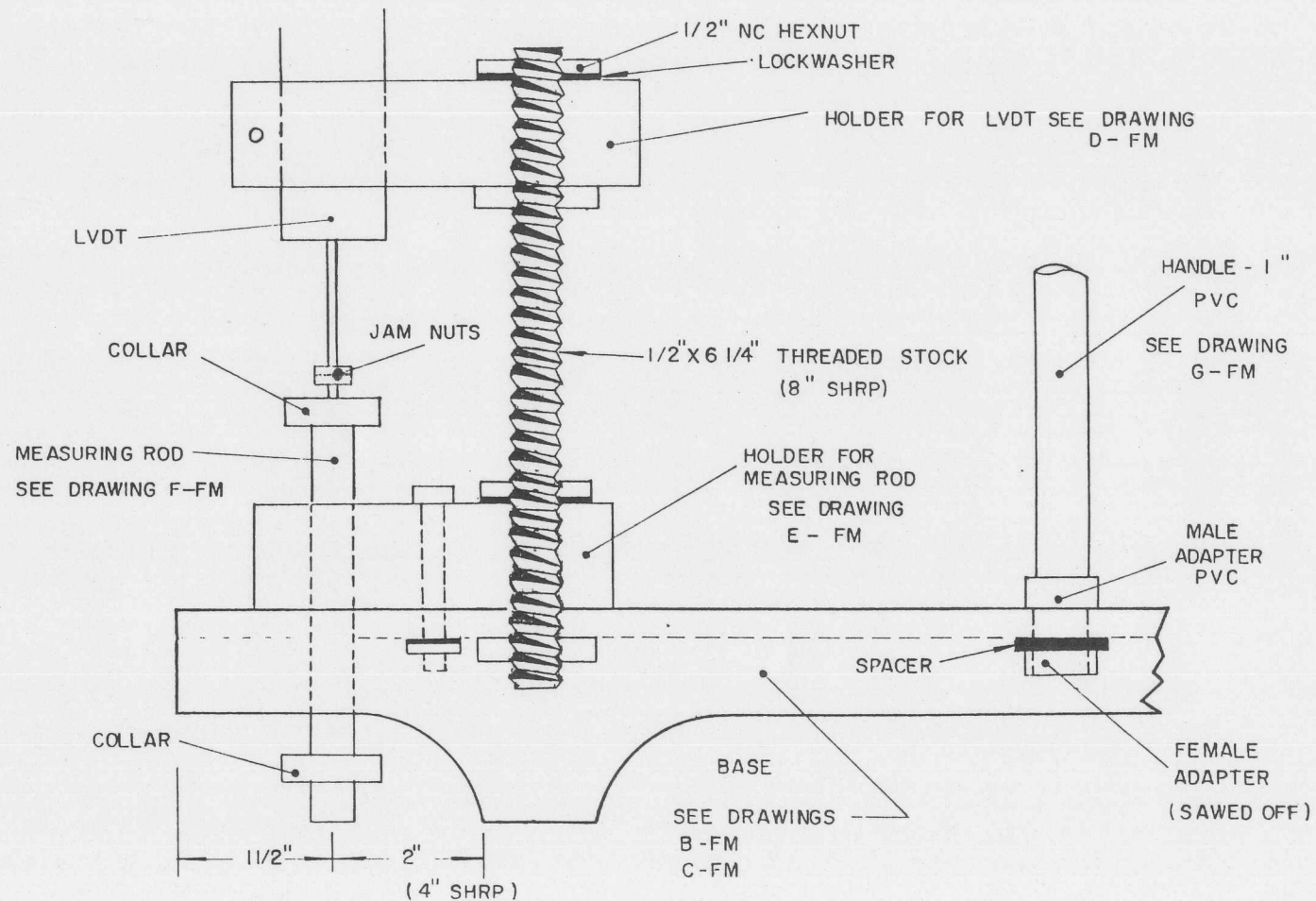
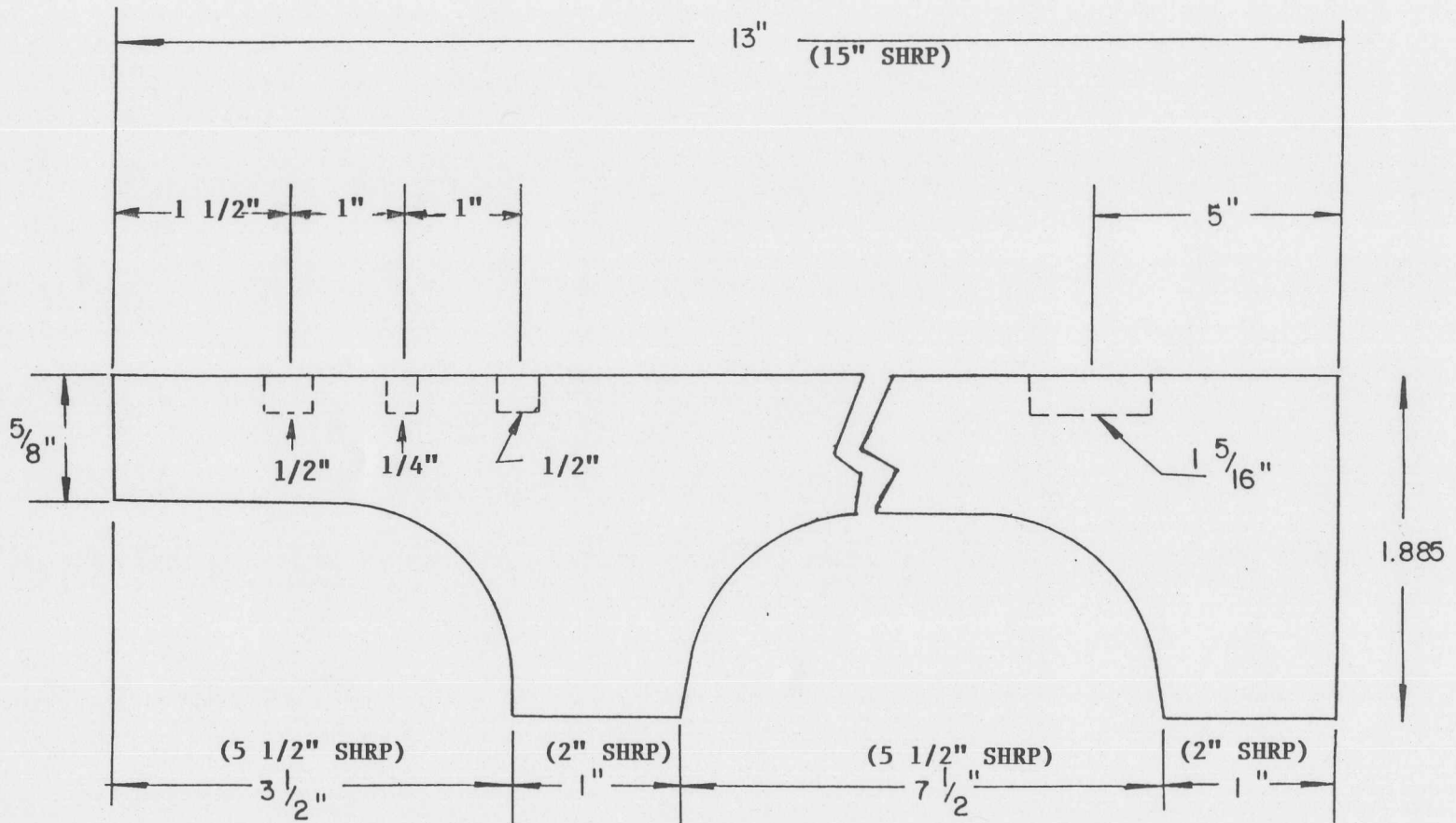

Figure 19. Drawing A-FM, Overall View of Faultmeter

GEORGIA FAULTMETER
 Georgia Department of Transportation
 Office of Materials and Research

-24-



Note: Base made from 5" aluminum channel - 0.325" Webb thickness and 1.885 flange width.

Figure 20. Drawing B-FM, Side View of Base Plate

GEORGIA FAULTMETER
Georgia Department of Transportation
Office of Materials and Research

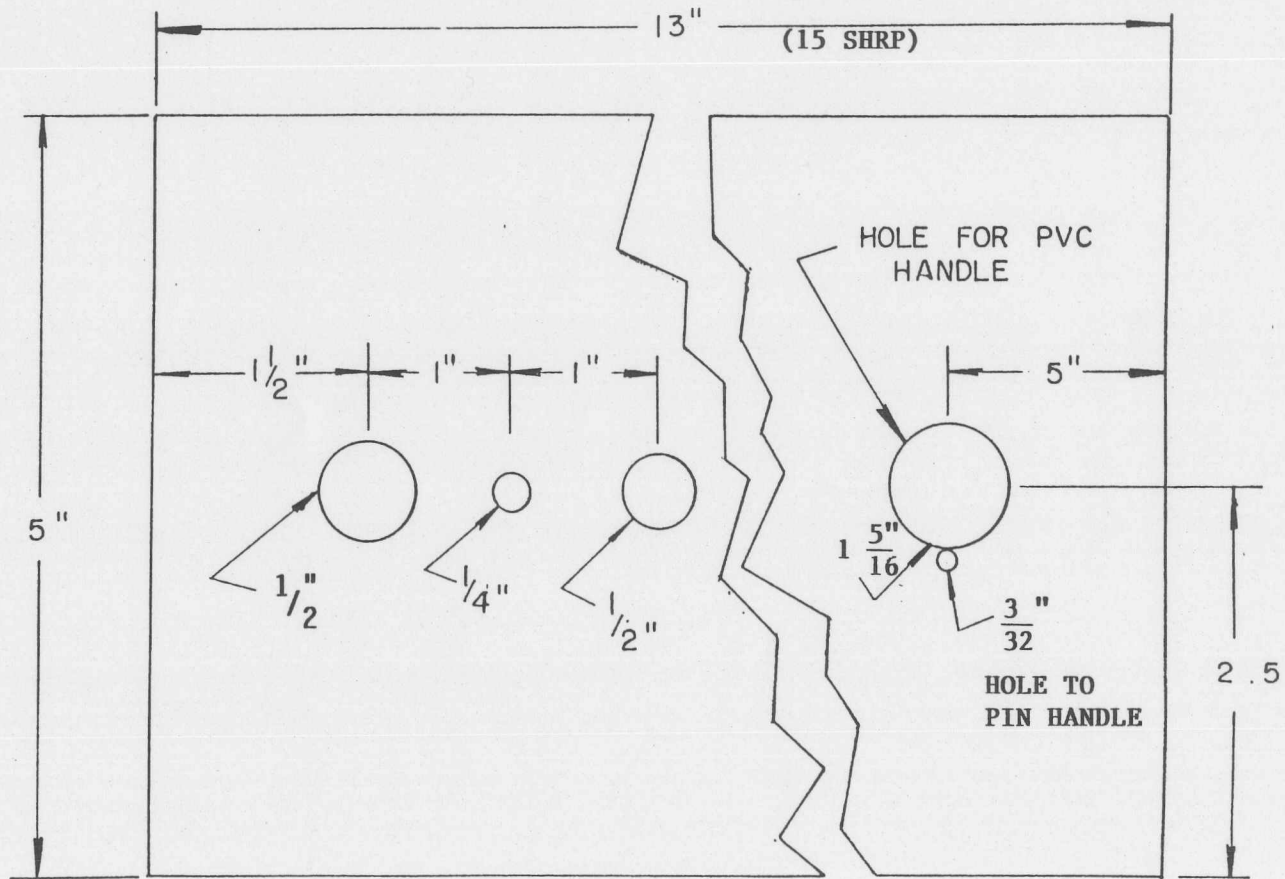
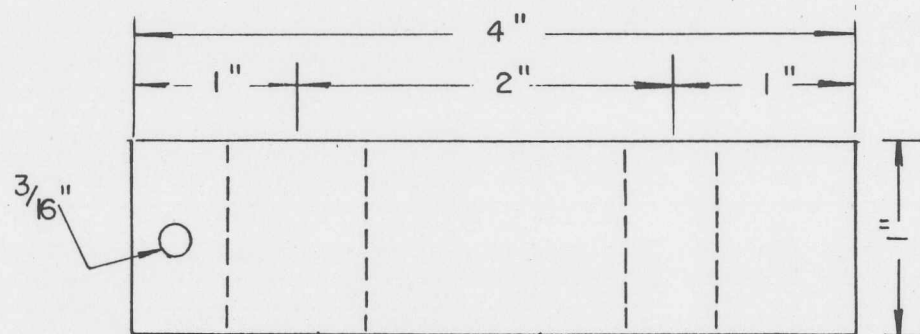
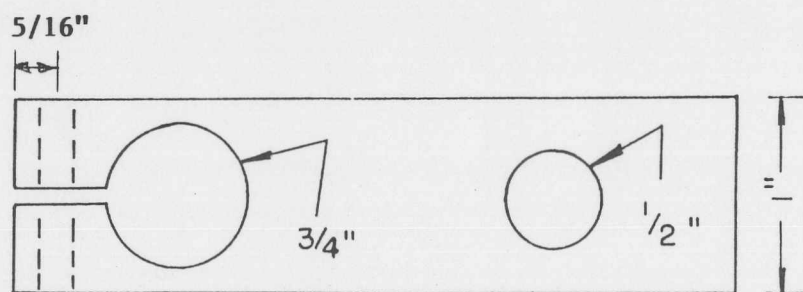

Figure 21. Drawing C-FM, Top View of Base Plate

GEORGIA FAULTMETER
Georgia Department of Transportation
Office of Materials and Research



Side View



Top View

Note: Use 1" Square Aluminum bar.

Figure 22. Drawing D-FM, Holder for LVDT

GEORGIA FAULTMETER
Georgia Department of Transportation
Office of Materials and Research

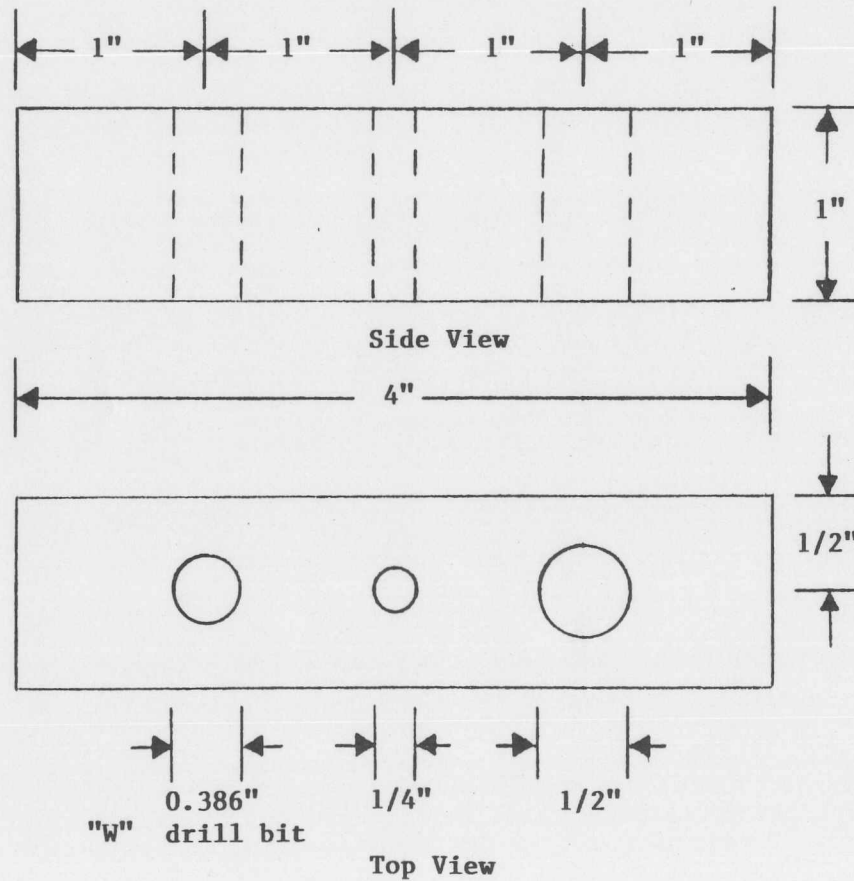

Note: Use 1" square aluminum bar.

Figure 23. Drawing E-FM, Holder for Measuring Rod

GEORGIA FAULTMETER
Georgia Department of Transportation
Office of Materials and Research

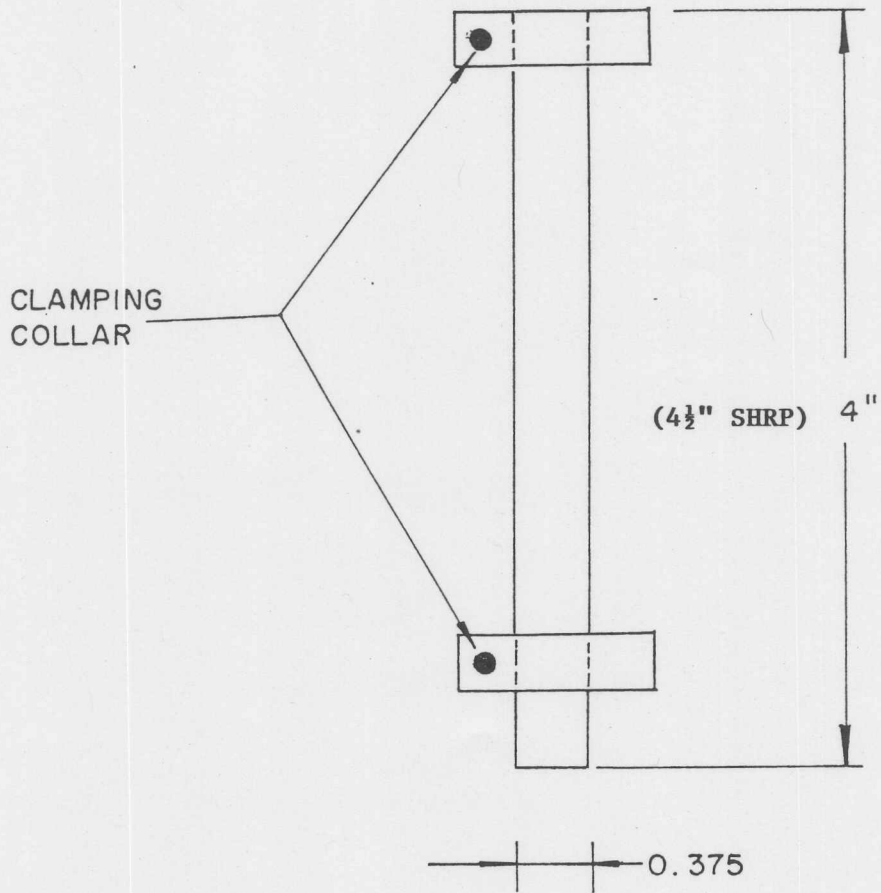

- Notes: 1. Use 3/8" stainless steel rod.
2. Polish both ends flat.

Figure 24. Drawing F-FM, Stainless Steel Measuring Rod

GEORGIA FAULTMETER
 Georgia Department of Transportation
 Office of Materials and Research

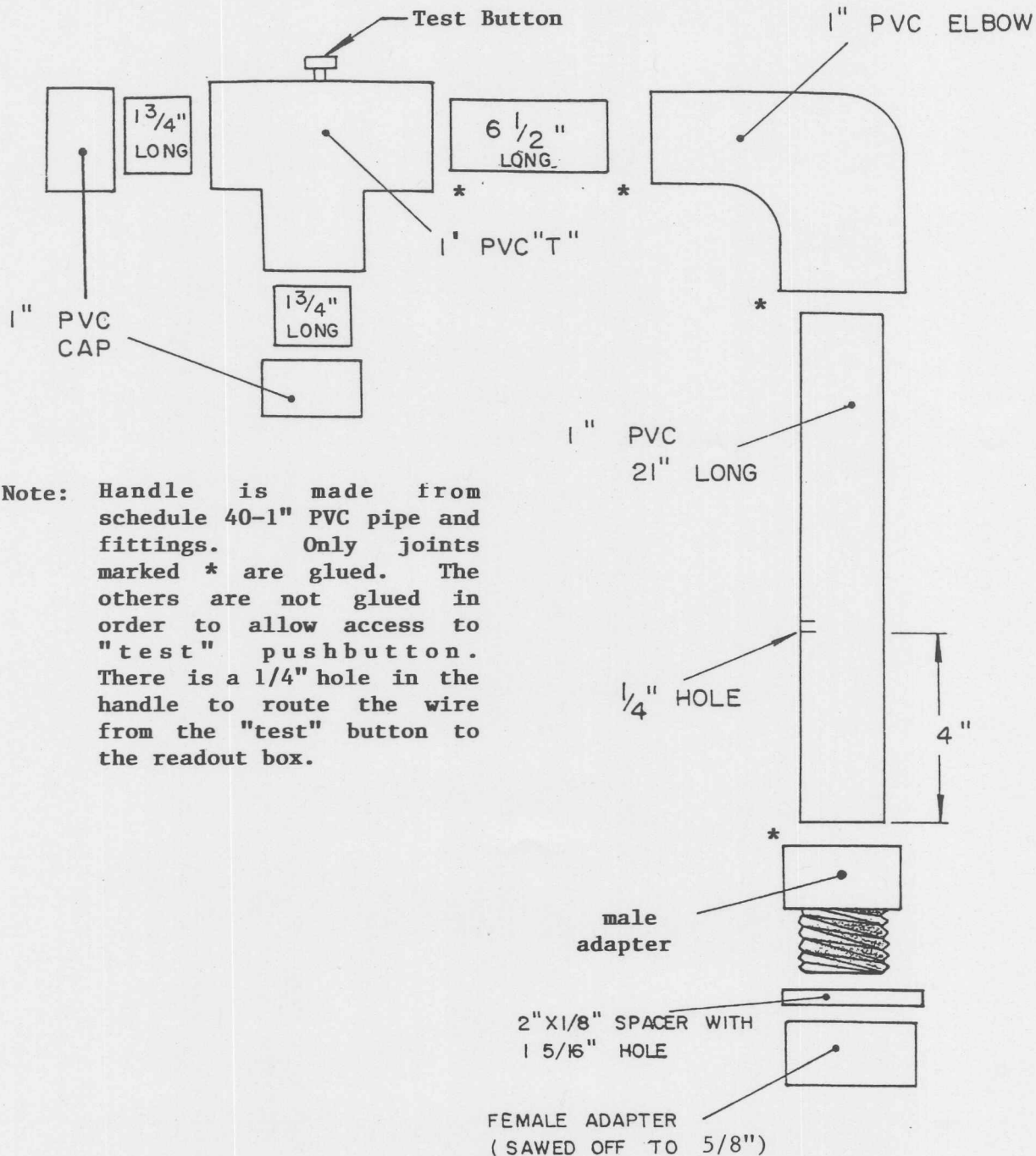

Note: Handle is made from schedule 40-1" PVC pipe and fittings. Only joints marked * are glued. The others are not glued in order to allow access to "test" pushbutton. There is a 1/4" hole in the handle to route the wire from the "test" button to the readout box.

Figure 25. Drawing G-FM, Faultmeter Handle

pipe to the "test" switch and (5) the round shape does not tire the hand when held for extended periods of time.

Note that only the marked joints should be permanently glued. The protective caps on the ends of the "T" should not be glued in case the "test" button should ever need replacing. The wire from the electronic box enters approximately 4" up the handle and goes to the "test" switch.

The handle is fastened to the base using a female pipe adapter. Since these are pipe threads, a spacer was required to get the adapter to tighten up against the base. A pin through the base into a pilot hole in the PVC handle assures the handle will not become loose and rotate. The adapter was sawed off to approximately 5/8" to be sure it cleared the pavement under the base.

Figure 26 shows top and bottom views of the electronics box. The top has a cut out for the faulting display. The digital meter used for the display is mounted directly to the inside of the box using homemade "Z" chumps shown in Figure 27. There is also an arrow showing direction of traffic and a hole for mounting the "off-on" switch on the top of the box.

The bottom view in Figure 26 shows the cut-out which allows the box to mount over the LVDT assemblies. Four holes allow mounting the box to the base. The battery pack mounts at the back of the box using the same type "Z" clamp previously mentioned.

Figure 27 shows a side and back view of the electronics cabinet. The 4 holes are used to mount the P.C. board to this side using the detail shown. The sonalert fits up against the 1/4" hole. This provides the audible tone when the test is "frozen" in the display. The guidelines mark the front of the leg and the measuring rod so the joint can be centered between them.

GEORGIA FAULTMETER
 Georgia Department of Transportation
 Office of Materials and Research

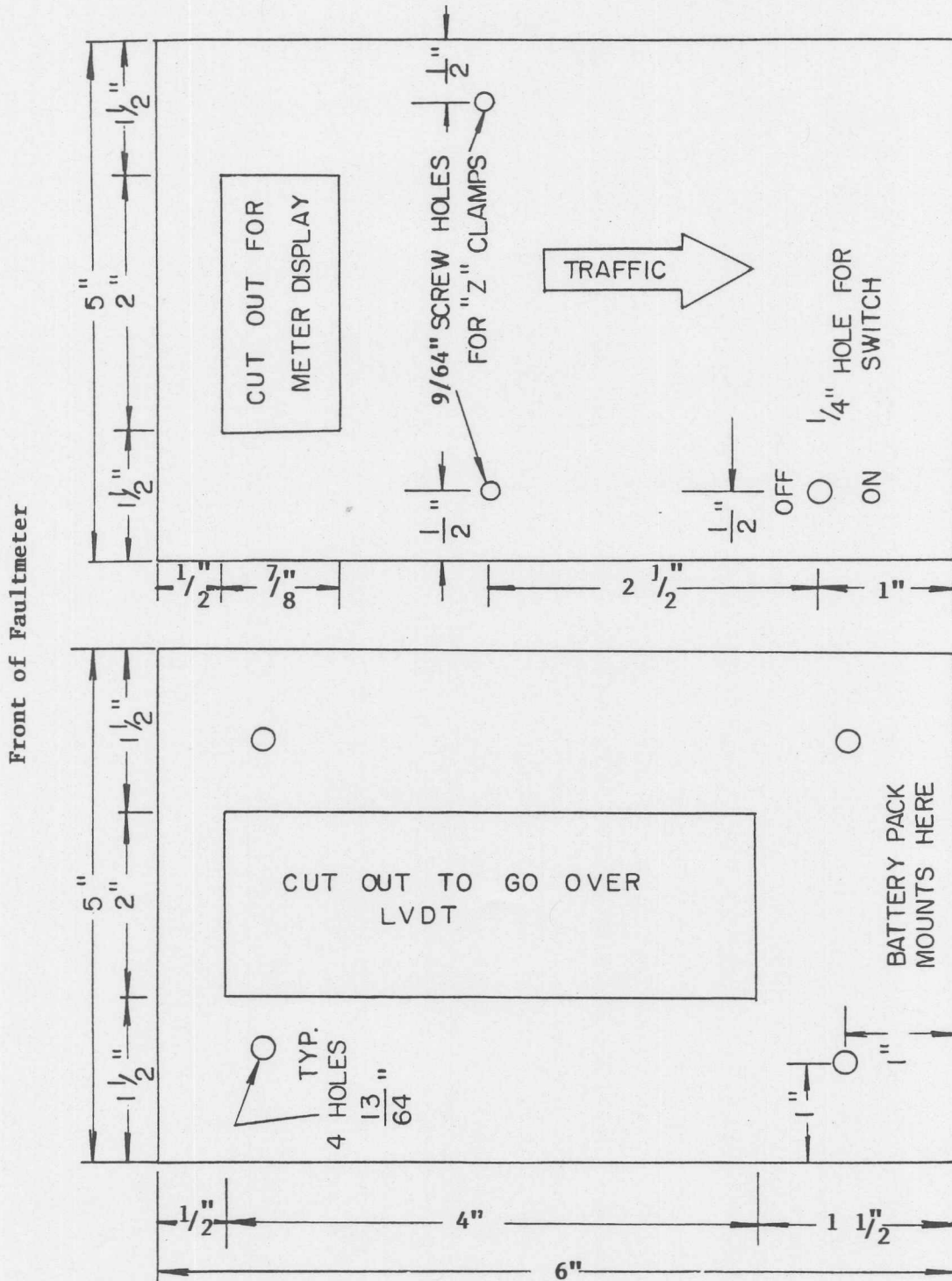
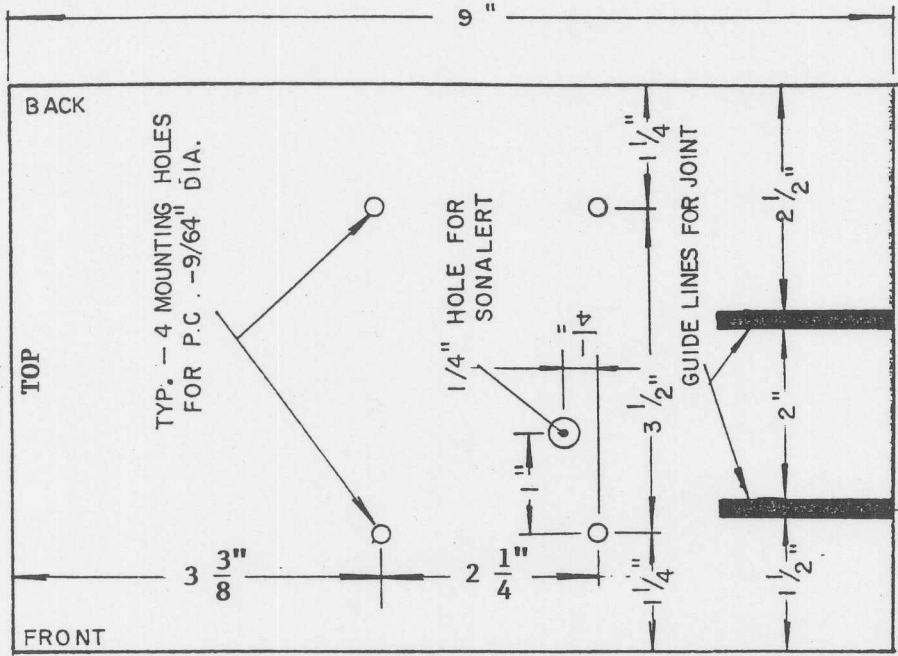
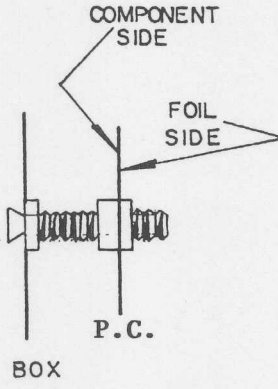

Figure 26. Drawing H-FM, Top and Bottom View of Electronic Cabinet (5" x 6" x 9")

GEORGIA FAULTMETER
 Georgia Department of Transportation
 Office of Materials and Research



RIGHT SIDE - LOOKING FROM FRONT OF METER



P.C. MOUNT-USE
 4 - 1 1/4" SCREWS

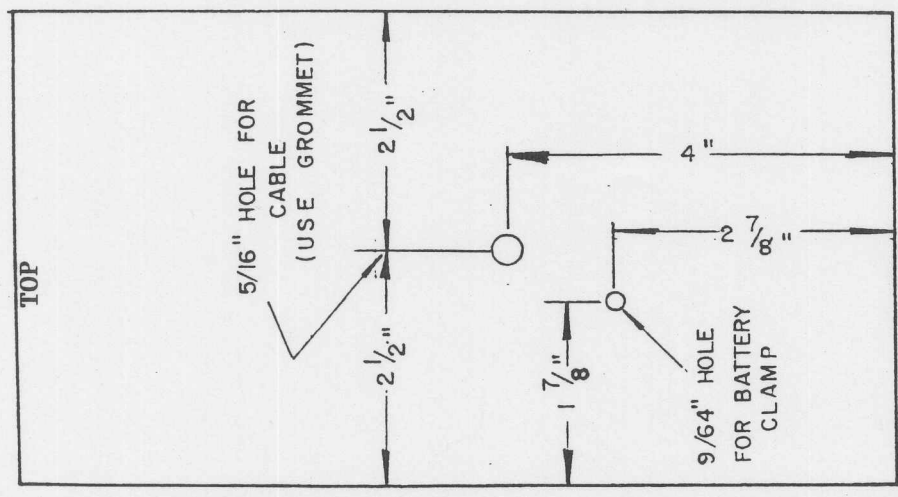

BACK OF CABINET

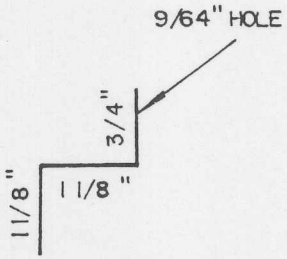

"Z" CLAMPS FOR
 METER & BATTERY-
 MAKE OUT OF SHEET
 METAL 3/4" WIDE

Figure 27. Drawing I-FM, Back and Side View of Electronics Cabinet (5" x 6" x 9")

The back of the cabinet has a hole for the cable which goes through the handle to the "test" button and a hole to mount the battery pack with a "Z" clamp. The "Z" clamps are shown in detail on Figure 27.

Figure 28 shows the plans for the calibration plate. The calibration plate base is made from the same type 5" aluminum channel used for the Georgia Faultmeter base. There are guide rails on each side of the unit simply to keep the meter from sliding off the plate. These rails are bent out slightly so the meter will freely slide along the top of the plate.

When the front of the faultmeter lines up with the "Cal 12" mark shown on the top view, the probe rests on the 3/8" thick spacer. As the meter reads in 32nds of an inch, a reading of 12 should be obtained since the spacer is 3/8" (or 12/32") thick. When the front of the meter is even with the zero mark, the probe is not on the spacer so the meter should read 0.

IX. MODIFICATIONS FOR SHRP

The Georgia Department of Transportation has built 4 faultmeters for SHRP. They were especially interested in measuring shoulder dropoff as well as joint faulting. SHRP requested several minor changes in the faultmeter. The modifications made for the Ga.-SHRP Faultmeter were:

1. The distance from the center of the measuring probe to the edge of the forward foot of the base was lengthened from 2" to 4". This allows easier placement on the joint and for more overhang to measure shoulder dropoff.
2. SHRP preferred the feet on the base be 2" rather than 1" wide to bridge any bad crack or low spot in the pavement.

GEORGIA FAULTMETER
 Georgia Department of Transportation
 Office of Materials and Research

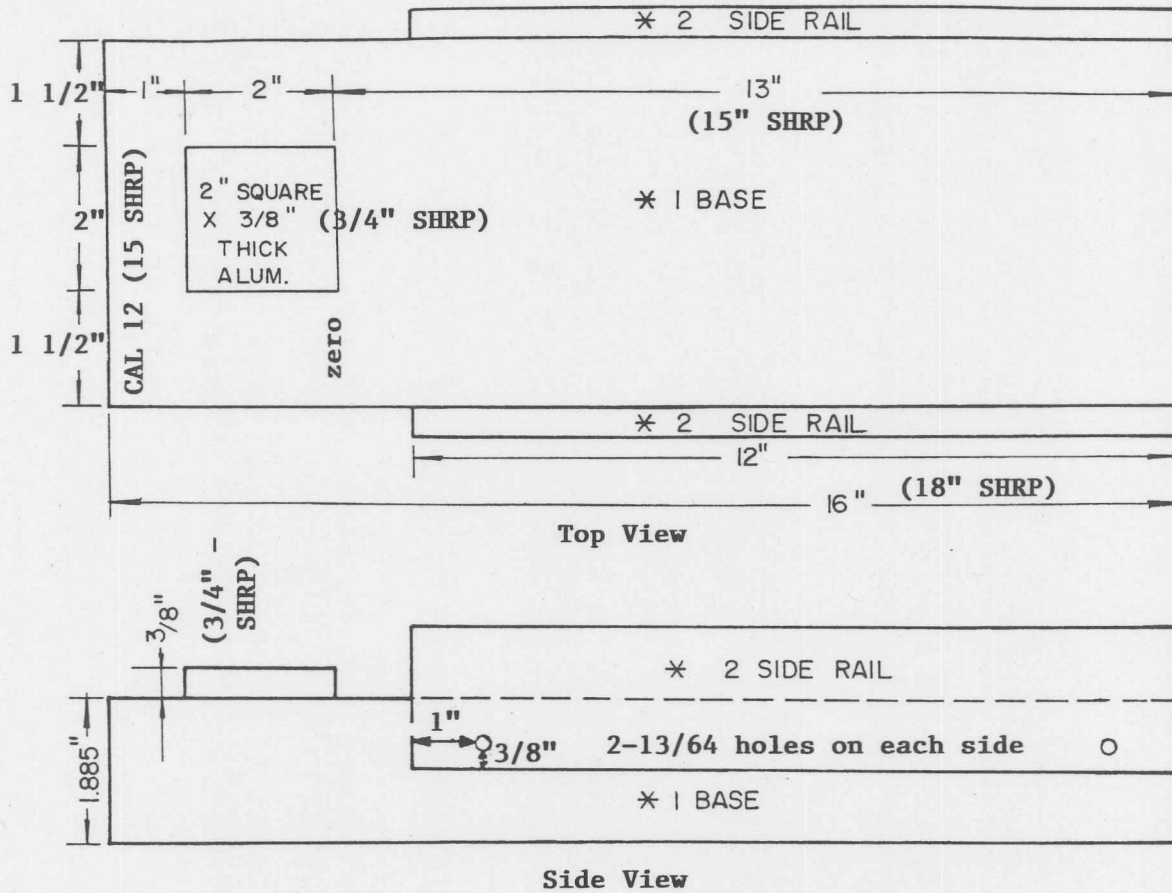

- Notes: * 1. Calibration stand made from same 5" aluminum channel used for Faultmeter base.
- * 2. Side rails made from 2" x 12" x 5/64" thick aluminum bent out slightly along the dotted line. The rails serve as a guide to align Faultmeter on calibration stand.

Figure 28. Drawing J-FM, Calibration Stand for Faultmeter

3. The maximum measurement was increased from 5/8 inch to one inch in order to be able to measure shoulder dropoff as well as to measure faulting more than 5/8 inch.
4. As a matter of preference, SHRP requested the gauge read out in 20ths of an inch rather than 32nds of an inch.

No major modifications were required. Change #1 requires a longer faultmeter base and calibration stand. Change #2 requires a slight change in machining the base. Change #3 requires buying a ± 1 " stroke LVDT. Both numbers are on the parts list. Change #4 requires no change in the electronics. The calibration control is simply adjusted to give the desired readout.

The following is a detailed listing of the changes required for each drawing in Section VIII. On Fig. 19, the 2" distance from the probe to the front foot was changed to 4" and the 1/2" threaded stock from 6 1/4" to 8" long. On Fig. 20, the total length should be 15" instead of 13". The width of the feet should be 2" instead of 1". The front overhang will be 5 1/2" instead of 3 1/2". Other measurements shown will stay the same.

The only measurement to change on Fig. 21 is a 15" total length instead of the 13" shown. Figures 22 and 23 require no changes. The stainless steel rod in Fig. 24 is changed to 4 1/2" long rather than 4". The handle shown in Fig. 25 remains the same.

Originally, a 5" x 6" x 9" box was used to house the LVDT and electronics. Since the SS-107 LVDT is longer, a taller box is required. A Bud #CU-3011-A was the only standard box that could be obtained. This box is 4" x 7" x 12"; however, any box that will house the LVDT and electronics can be used. The dimensions in Figures 26 and 27 will have to be adjusted for a different box, but the layout will remain similar.

The total length of the calibration stand shown in Fig. 28 should be 18" rather than 16". Since the GA-SHRP Faultmeter has a larger measurement range, the calibration spacer was changed from 3/8" to 3/4" thick. Since the readings will be in 20ths of an inch, the calibration will be 3/4" x 20 = 15. Make the calibration position on the stand read "cal 15" instead of "cal 12." Follow the calibration instructions in Section V, except to set the calibration to 15 rather than 12.

The electronic parts list in Table 1 will stay the same except for the LVDT and the box used to house the electronics. The LVDT used is a model SS-107 instead of the SS-105. A Bud # CU-3011-A or similar is used instead of the AU-1040. An optional Radio-Shack #274-201 and 274-202 plug and jack were used for the wire between the electronics box and the handle. This allows the handles to be removed for shipping.

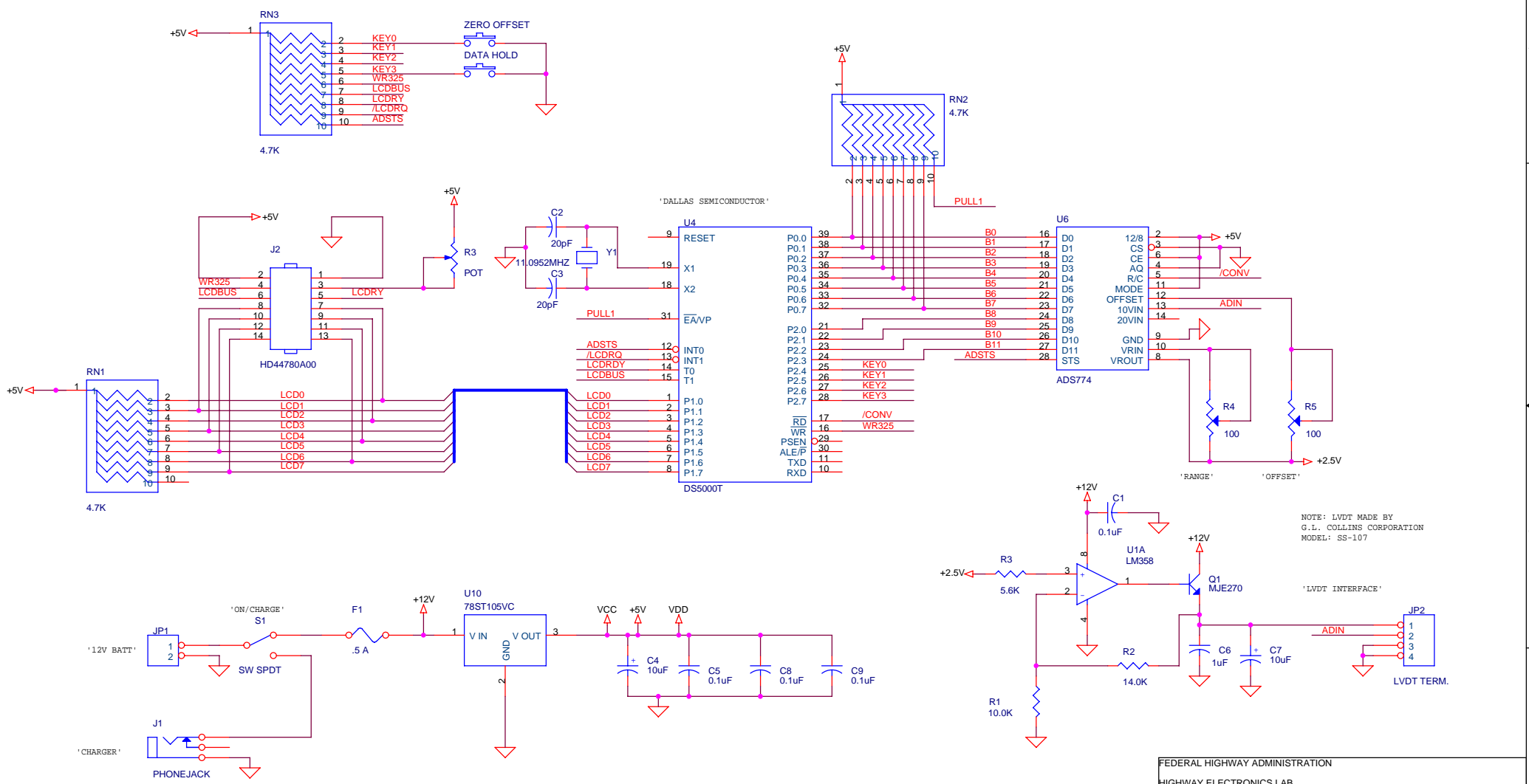

NOTE: LVDT MADE BY
G.L. COLLINS CORPORATION
MODEL: SS-107

'LVDT INTERFACE'

JP2
1
2
3
4
LVDT TERM.

FEDERAL HIGHWAY ADMINISTRATION		
HIGHWAY ELECTRONICS LAB. 6300 GEORGETOWN PIKE McLEAN, VA 22101		
Title	FAULT METER Version 3	
Size	Document Number	Rev
B	FAULTMTR.DSN	
Date:	Wednesday, August 29, 2007	Sheet 1 of 1

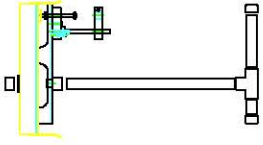
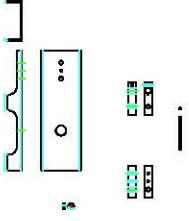
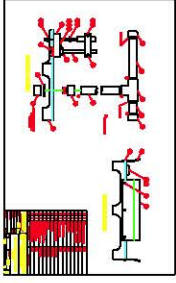
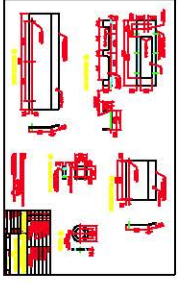
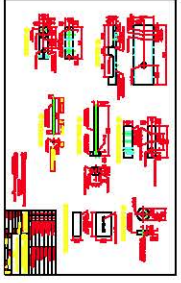

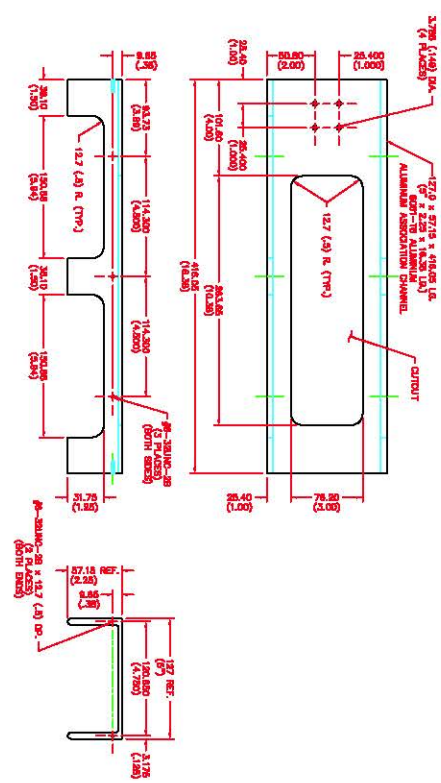

7) CALIBRATOR BASE

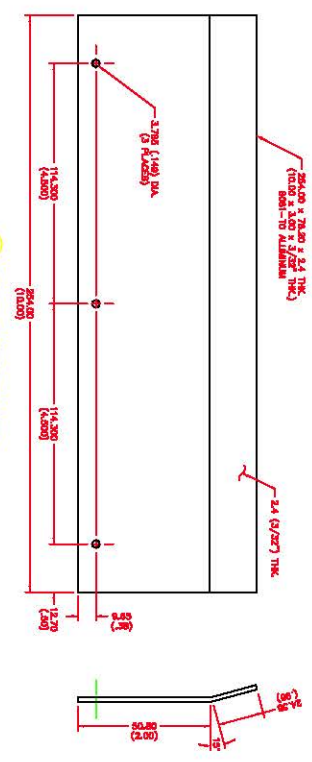

8) SIDE GUIDE PLATE

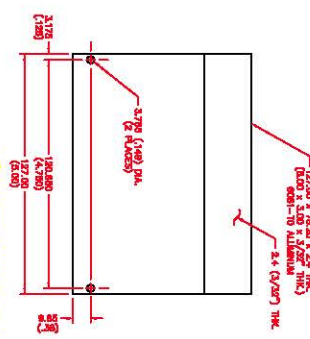

9) END GUIDE PLATE

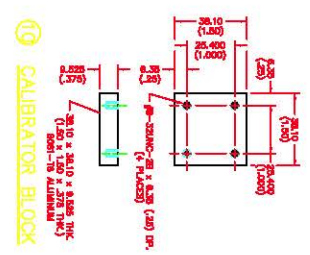

10) CALIBRATOR BLOCK

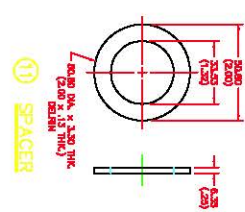

11) SPACER

- NOTES:
- 1) ALL DIMENSIONS ARE IN MILLIMETERS (DIMENSIONS IN PARENTHESES)
 - 2) TOLERANCES ARE AS FOLLOWS: X.XXX - 0.01 (0.01)
 - 3) SURFACE FINISH FOR UNCOATED SURFACES: 12.5 (12.5) UNLESS OTHERWISE SPECIFIED.

REV	DATE	BY	CHKD	DESCRIPTION
11				REVISED TO ADD 11.2
10				COMPARISON BASE
9				0.005 TYP & 0.005 TYP
8				0.005 TYP & 0.005 TYP
7				0.005 TYP & 0.005 TYP
6				0.005 TYP & 0.005 TYP
5				0.005 TYP & 0.005 TYP
4				0.005 TYP & 0.005 TYP
3				0.005 TYP & 0.005 TYP
2				0.005 TYP & 0.005 TYP
1				0.005 TYP & 0.005 TYP

U.S. DEPT. OF TRANSPORTATION
 FEDERAL HIGHWAY ADMINISTRATION
 RESEARCH & DEVELOPMENT

GEORGIA DIGITAL PALLADIUM
 07043

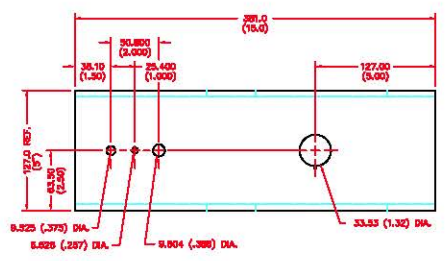

1 BASE PLATE

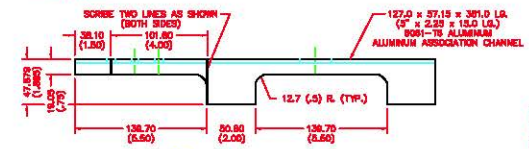

2 LVDT HOLDER

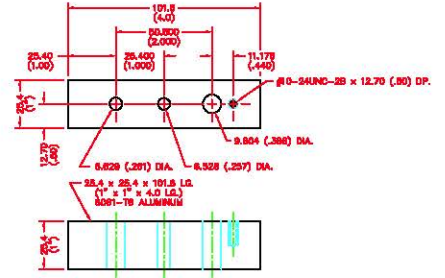
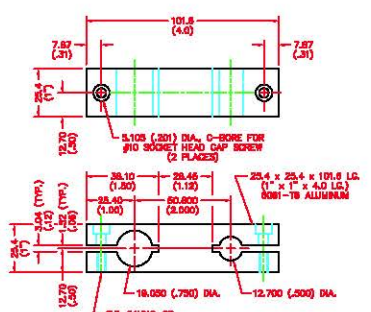

3 MEASURING ROD HOLDER

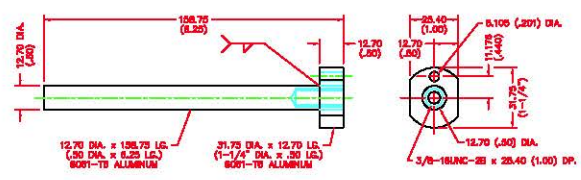

4 VERTICAL SUPPORT

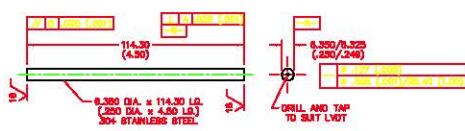

5 MEASURING ROD

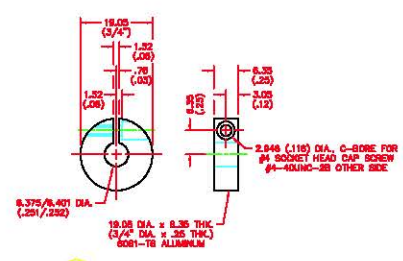

6 CLAMPING COLLAR

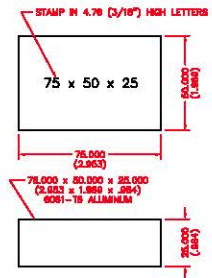

PRECISION CALIBRATING BLOCK

NOTES:
 1.) ALL DIMENSIONS ARE IN MILLIMETERS. (INCHES IN PARENTHESIS)
 2.) TOLERANCES ARE AS FOLLOWS: X.0 = ±0.03
 X.30 = ±0.12 (0.1)
 X.300 = ±0.12 (0.05)
 3.) REMOVE ALL SHARP EDGES.
 4.) SURFACE FINISH FOR MACHINED SURFACES: 125 μm UNLESS OTHERWISE SPECIFIED.

ITEM NO.	QTY.	NOMENCLATURE	SPECIFICATION
6	2	CLAMPING COLLAR (19.05 DIA. x 19.05 THK.)	6061-T6 ALUMINUM
3	1	MEASURING ROD (12.70 DIA. x 4.50 LG.)	304 STAINLESS STEEL
4	1	VERTICAL SUPPORT (SEE DETAIL)	PLATED STEEL
3	1	MEASURING ROD HOLDER (12.70 DIA. x 4.0 LG.)	6061-T6 ALUMINUM
2	1	LVDT HOLDER (12.70 DIA. x 4.0 LG.)	6061-T6 ALUMINUM
1	1	BASE PLATE (127.0 x 301.0 x 127.0)	6061-T6 ALUMINUM ALUMINUM ASSOCIATION CHANNEL

DESIGNER	DATE	APPROVED	DATE
AWG			

ORGANIZATION	DATE	REV. NO.	REV.
		4150	

U.S. DEPT. OF TRANSPORTATION FEDERAL HIGHWAY ADMINISTRATION RESEARCH & DEVELOPMENT
GEORGIA DIGITAL FAULTMETER DETAILS
REV. 1 OF 1

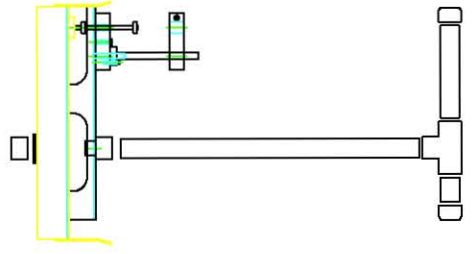
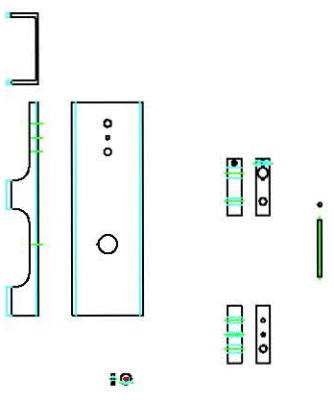
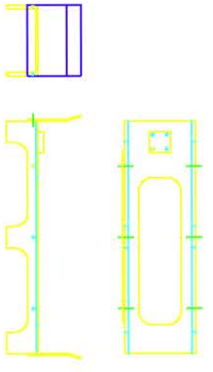

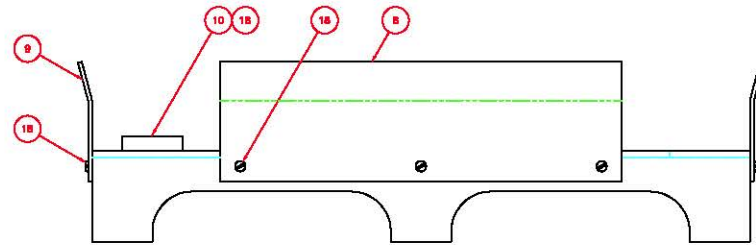
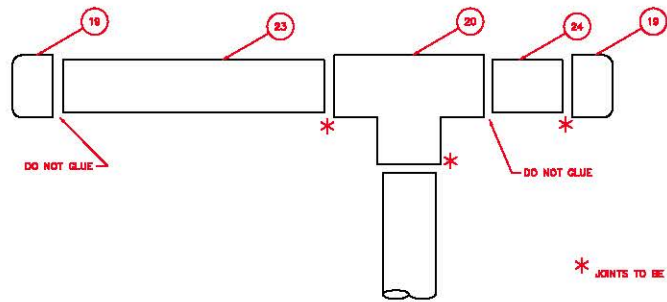

CALIBRATOR ASSEMBLY

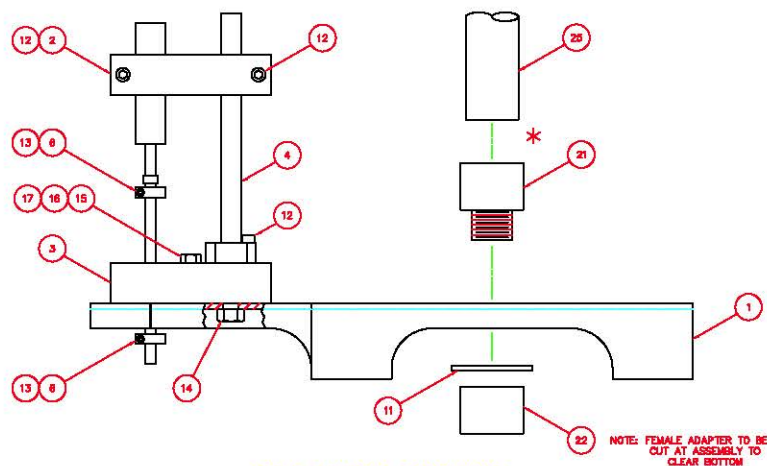

FAULTMETER ASSEMBLY

25	1	PIPE SCH. 40, 1" NOM. x 48.0 (18.0) L.	P.V.C.
24	1	PIPE SCH. 40, 1" NOM. x 45.7 (1.8) L.	P.V.C.
23	1	PIPE SCH. 40, 1" NOM. x 188.1 (8.6) L.	P.V.C.
22	1	FEMALE ADAPTER SCH. 40, 1" NOM.	P.V.C.
21	1	MALE ADAPTER SCH. 40, 1" NOM.	P.V.C.
20	1	TEE SCH. 40, 1" NOM., 2 x 2	P.V.C.
19	2	CAP SCH. 40, 1" NOM., 2 x 2	P.V.C.
18	14	PAN HEAD MACHINE SCREW #2-32X10-24 x 0.80 (3.20) L.	PLATED STEEL
17	1	HEX NUT 1/4-20X10-28	PLATED STEEL
16	1	LOCKWASHER 1/4" NOM.	PLATED STEEL
15	1	HEX HEAD CAP SCREW 1/4-20X10-24 x 0.810 (3.20) L.	PLATED STEEL
14	1	HEX HEAD CAP SCREW 3/8-16X10-24 x 0.448 (1.76) L.	PLATED STEEL
13	2	SOCKET HEAD CAP SCREW #2-32X10-24 x 1.870 (7.40) L.	STEEL
12	3	SOCKET HEAD CAP SCREW #2-32X10-24 x 1.608 (6.30) L.	STEEL
QTY.		NOMENCLATURE	SPECIFICATION
OFFICE OF OPERATIONS AND HIGHWAY OPERATIONS		U.S. DEPT. OF TRANSPORTATION	
NATIONAL CENTER FOR TRANSPORTATION RESEARCH		FEDERAL HIGHWAY ADMINISTRATION	
RESEARCH CENTER		RESEARCH & DEVELOPMENT	
DATE	DATE	GEORGIA DIGITAL FAULTMETER	
APPROVED:	DATE	ASSEMBLER	
ORGANIZATION	DATE	REV.	REV.
		4150	B