

# **LTPP SEASONAL MONITORING PROGRAM: INSTRUMENTATION INSTALLATION AND DATA COLLECTION GUIDELINES**

Version 2.1

---

Prepared by:

FHWA-LTPP Technical Assistance Contractor  
Pavement Consultancy Services  
A Division of Law Engineering, Inc.  
12240 Indian Creek Court, Suite 120  
Beltsville, Maryland 20705-1242

Western Regional Coordination Office  
Nichols Consulting Engineers, Chtd.  
1885 S. Arlington Avenue, Suite 111  
Reno, Nevada 89509

North Atlantic Regional Coordination Office  
Pavement Management Systems, Ltd.  
415 Lawrence Bell Drive  
Amherst, New York 14221

North Central Regional Coordination Office  
Braun Intertec Pavement, Inc.  
1983 Sloan Place  
St. Paul, Minnesota 55117-2004

April 1994

|   |  |  |  |   |           |
|---|--|--|--|---|-----------|
| 1. Report No.<br>FHWA-RD-94-110   |  | 2. Government Accession No.                          |  | 3. Recipient's Catalog No.  |           |
| 4. Title and Subtitle<br>LTPP SEASONAL MONITORING PROGRAM:<br>INSTRUMENTATION INSTALLATION AND<br>DATA COLLECTION GUIDELINES  |  |  |  | 5. Report Date<br>January 1995  |           |
|   |  |  |  | 6. Performing Organization Code   |           |
| 7. Author(s)<br>Rada, G.R., Elkins, G.E., Henderson, B., and Van<br>Sambeek, R.J., Lopez, Jr., A.   |  |  |  | 8. Performing Organization Report No.<br>792-92-03741   |           |
| 9. Performing Organization Name and Address<br>PCS/Law Engineering<br>12104 Indian Creek Court, Suite A<br>Beltsville, Maryland 20705   |  |  |  | 10. Work Unit No. (TRAILS)<br>NCP #3C6A   |           |
|   |  |  |  | 11. Contract or Grant No.<br>DTFH61-92-C-00134  |           |
| 12. Sponsoring Agency Name and Address<br>Office of Engineering and Highway Operations R&D<br>Federal Highway Administration<br>6300 Georgetown Pike<br>McLean, Virginia 22101-2296   |  |  |  | 13. Type of Report and Period Covered<br>Final report<br>Sept. 1992 - Apr. 1994   |           |
|   |  |  |  | 14. Sponsoring Agency Code  |           |
| 15. Supplementary Notes<br><br>Contracting Officer's Technical Representative - Aramis Lopez, HNR-40  |  |  |  |   |           |
| 16. Abstract<br><br>This report describes the operation theory, installation procedures and operation guidelines for instrumentation selected to monitor changes in internal pavement moisture and thermal regimes, frost/thaw conditions, and external climate at test sections in the long-term pavement performance seasonal monitoring study. The instrumentation includes time domain reflectometry to measure moisture content of unbound materials, thermistor sensors to measure pavement temperature gradients and air temperature, electrical resistivity probes to measure frost locations, a piezometer to measure the depth of ground water table and tipping-bucket rain gauge to measure precipitation. These measurements of the external climate and the resulting changes in the pavement material will be coupled with monthly or more frequent deflection measurements, seasonal roughness measurements, elevation profile and distress surveys to study the cause and effects of seasonal changes in pavement structural response. Guidelines and procedures for the collection of these data are also described in this report. |  |  |  |   |           |
| 17. Key Words<br>Pavement Performance; Seasonal Monitoring; Data<br>Collection; Pavement Instrumentation; Field Testing;<br>Moisture, Temperature, and Frost/Thaw Measurements;<br>Pavement Testing   |  |  |  | 18. Distribution Statement<br>No restrictions. This<br>document is available to the<br>public through the National<br>Technical Information Service,<br>Springfield, VA 22161 |           |
| 19. Security Classif. (of this report)<br>Unclassified  |  | 20. Security Classif. (of this page)<br>Unclassified |  | 21. No. of Pages<br>214   | 22. Price |

## **PREFACE**

It is widely recognized that temperature, moisture, and frost/thaw related changes in pavement structures, both within a day, and over the course of a year, can have a significant impact on structural characteristics of pavement layers, thereby affecting response of the pavement to traffic loads, and ultimately the life of the pavement. However, the magnitude and relationship of these effects are not well understood, making them difficult to address (with any degree of accuracy or confidence) in pavement design and evaluation.

The Seasonal Monitoring Program (SMP) within the long-term pavement performance (LTPP) study intends to begin to rectify this situation. Products of the LTPP seasonal monitoring effort will provide (1) the means to link pavement response data obtained at random points in time to critical design conditions; (2) the means to validate models for relationships between environmental conditions (e.g., temperature and precipitation) and in situ structural properties of pavement materials; and (3) expanded knowledge of the magnitude and impact of the changes involved.

This manual was developed for use by personnel responsible for installing moisture, temperature and frost/thaw instrumentation, and collecting data in pavement test sections in the seasonal monitoring program. The manual presents an overview of the seasonal monitoring instrumentation, provides guidelines for the installation and operation of this instrumentation, and provides guidelines for the collection of seasonal monitoring data.

People involved with seasonal monitoring are encouraged to discuss the contents of this manual with the four LTPP Regional Coordination Office Contractors (RCOC's). The RCOC's will keep FHWA-LTPP Division staff informed of necessary changes. Periodic review and necessary updates to the manual will help keep the guidelines current and maintain uniform installation and monitoring procedures among the four regions.

## TABLE OF CONTENTS

|  | <u>Page</u> |
|--|-------------|
| I. INTRODUCTION . . . . .                                  | I-1         |
| II. SEASONAL MONITORING INSTRUMENTATION . . . . .          | II-1        |
| <i>INSTRUMENTATION OVERVIEW</i> . . . . .                  | II-1        |
| Moisture Content Measurement . . . . .                     | II-1        |
| Temperature Measurement . . . . .                          | II-5        |
| Frost/Thaw Depth Measurement . . . . .                     | II-6        |
| Ground Water Depth Measurement . . . . .                   | II-12       |
| Climatic Measurements . . . . .                            | II-12       |
| Other Related Equipment . . . . .                          | II-15       |
| Equipment Cabinet . . . . .                                | II-15       |
| Mobile Recording Equipment . . . . .                       | II-15       |
| Onsite Recording Equipment . . . . .                       | II-16       |
| Manual Measurement Equipment . . . . .                     | II-21       |
| <i>INSTALLATION GUIDELINES</i> . . . . .                   | II-23       |
| Installation Layout . . . . .                              | II-23       |
| Roles and Responsibilities . . . . .                       | II-23       |
| Pre-Installation Activities . . . . .                      | II-29       |
| Creation of an RCOC Installation Team . . . . .            | II-29       |
| Collection of Test Section Information . . . . .           | II-29       |
| Preliminary Site Review . . . . .                          | II-31       |
| Onsite Inspection . . . . .                                | II-33       |
| Preliminary Planning Meeting with Highway Agency . . . . . | II-33       |
| Equipment, Supplies and Materials . . . . .                | II-34       |
| Equipment Assembly . . . . .                               | II-34       |
| Instrumentation Calibration & Function Checks . . . . .    | II-40       |
| Pre-Installation Meeting with Highway Agency . . . . .     | II-50       |
| Installation Activities . . . . .                          | II-50       |
| First Day Activities . . . . .                             | II-50       |
| Second Day Activities . . . . .                            | II-64       |
| Post-Installation Activities . . . . .                     | II-67       |
| Report Submittal and Distribution . . . . .                | II-67       |
| Report Contents . . . . .                                  | II-67       |
| Report Format . . . . .                                    | II-67       |
| <i>INSTRUMENTATION OPERATION GUIDELINES</i> . . . . .      | II-69       |
| Manual Data Acquisition . . . . .                          | II-69       |
| TDR Sensors . . . . .                                      | II-69       |
| Thermistor Probe . . . . .                                 | II-70       |
| Electrical Resistivity Probe . . . . .                     | II-70       |
| Automated Data Acquisition . . . . .                       | II-72       |

|   |               |
|---|---------------|
| <b>III. SEASONAL MONITORING DATA COLLECTION</b> . . . . .                           | <b>III-1</b>  |
| <b>DEFLECTION DATA</b> . . . . .  | <b>III-1</b>  |
| Core Experiment . . . . .   | <b>III-1</b>  |
| Supplemental Studies . . . . .  | <b>III-5</b>  |
| <b>RELATED DATA</b> . . . . .   | <b>III-6</b>  |
| Core Experiment . . . . .   | <b>III-6</b>  |
| FWD Pavement Surface and Air Temperature . . . . .                                  | <b>III-6</b>  |
| Manual Surface Layer Temperature Profile . . . . .                                  | <b>III-6</b>  |
| Moisture Profiles . . . . .   | <b>III-6</b>  |
| Automated Temperature Profiles . . . . .  | <b>III-7</b>  |
| Depth of Frost/Thaw . . . . .   | <b>III-7</b>  |
| Depth of Ground water Table . . . . .   | <b>III-7</b>  |
| Ambient Air Temperature and Precipitation . . . . .                                 | <b>III-12</b> |
| Joint Openings (Rigid Pavements) . . . . .  | <b>III-12</b> |
| Joint Faulting (Rigid Pavements) . . . . .  | <b>III-12</b> |
| Supplemental Studies . . . . .  | <b>III-15</b> |
| <b>ELEVATION AND PROFILE DATA</b> . . . . .   | <b>III-15</b> |
| Core Experiment . . . . .   | <b>III-15</b> |
| Supplemental Studies . . . . .  | <b>III-23</b> |
| <b>DISTRESS SURVEYS</b> . . . . .   | <b>III-23</b> |
| Core Experiment . . . . .   | <b>III-23</b> |
| Supplemental Studies . . . . .  | <b>III-23</b> |
| <b>SYNTHESIS OF DATA COLLECTION ACTIVITIES AND REQUIREMENTS</b> . . . . .           | <b>III-23</b> |
| Activities to Complete Prior to Site Arrival . . . . .                              | <b>III-32</b> |
| Activities at Site Prior to Start of FWD Testing . . . . .                          | <b>III-32</b> |
| Activities in Conjunction with FWD . . . . .  | <b>III-36</b> |
| Activities After FWD Testing Completed . . . . .                                    | <b>III-38</b> |
| <b>FILE NAMING AND DATA HANDLING</b> . . . . .                                      | <b>III-39</b> |
| <br>  |               |
| <b>APPENDIX A: SEASONAL MONITORING PROGRAM DATA SHEETS</b> . . . . .                | <b>A-1</b>    |
| <br>  |               |
| <b>APPENDIX B: SEASONAL MONITORING PROGRAM AUTOMATED DATA ACQUISITION</b> . . . . . | <b>B-1</b>    |

**LIST OF FIGURES**

| <u>Figure</u>  | <u>Page</u> |
|--|-------------|
| II- 1 - TDR Probe for SMP (developed by FHWA) . . . . .                            | II-3        |
| II- 2 - Typical TDR Signal . . . . .   | II-4        |
| II- 3 - Thermistor Probe for SMP (manufactured by MRC) . . . . .                   | II-7        |
| II- 4 - Electrical Resistivity Probe for SMP (developed by CRREL) . . . . .        | II-9        |
| II- 5 - Electrical Resistance Measurements - CRREL Probe . . . . .                 | II-11       |
| II- 6 - Observation Piezometer for SMP . . . . .                                   | II-13       |
| II- 7 - Rain Gauge and Temperature Probe for SMP . . . . .                         | II-14       |
| II- 8 - Wiring Diagram for TDR System . . . . .                                    | II-17       |
| II- 9 - Wiring Diagram for Mobile CR10 Datalogger . . . . .                        | II-18       |
| II-10 - Layout of Mobile Data Recording Unit . . . . .                             | II-19       |
| II-11 - Wiring Diagram for Onsite CR10 Datalogger . . . . .                        | II-20       |
| II-12 - Typical Instrumentation Layout . . . . .                                   | II-24       |
| II-13 - Illustration of Instrumentation Installation . . . . .                     | II-26       |
| II-14 - Snap Ring Placement for Measuring Joint Openings - PCC Pavements . . . . . | II-66       |
| III- 1 - Deflection Data Collection Plan - AC Pavements . . . . .                  | III-2       |
| III- 2 - Deflection Data Collection Plan - JPC Pavements . . . . .                 | III-3       |
| III- 3 - Deflection Data Collection Plan - JRC Pavements . . . . .                 | III-4       |
| III- 4 - Elevation and Profile Data Collection Plan - AC Pavements . . . . .       | III-17      |
| III- 5 - Elevation and Profile Data Collection Plan - JPC Pavements . . . . .      | III-18      |
| III- 6 - Elevation and Profile Data Collection Plan - JRC Pavements . . . . .      | III-19      |

**LIST OF TABLES**

Table

|  |        |
|--|--------|
| I- 1 - SMP Core Experiment: Experimental Design Cells and Target Number of Sections per Cell . . . . .     | I-2    |
| I- 2 - SMP Data Elements . . . . .   | I-3    |
| II- 1 - Roles and Responsibilities - Core Experiment . . . . .   | II-27  |
| II- 2 - Roles and Responsibilities - Supplemental Studies . . . . .  | II-28  |
| II- 3 - RCOC Installation Team . . . . .   | II-30  |
| II- 4 - Sample Agenda for Preliminary Planning Meeting . . . . .   | II-35  |
| II- 5 - List of Materials Required for Instrumentation Installation . . . . .                              | II-36  |
| II- 6 - List of Equipment Required for Instrumentation Installation . . . . .                              | II-37  |
| II- 7 - Materials for Instrumentation and Measurement Equipment . . . . .                                  | II-38  |
| II- 8 - Materials for Observation Piezometer/Benchmark . . . . .   | II-39  |
| II- 9 - Schedule of Activities - Day 1 . . . . .   | II-52  |
| II- 10- Seasonal Report Contents . . . . .   | II-68  |
| III- 1 - Data Collection Activities: Core Experiment - Flexible Pavements (Frost Areas) . . . . .          | III-24 |
| III- 2 - Data Collection Activities: Core Experiment - Flexible Pavements (Non-Frost Areas) . . . . .      | III-25 |
| III- 3 - Data Collection Activities: Core Experiment - Rigid Pavements (Frost Areas) . . . . .             | III-26 |
| III- 4 - Data Collection Activities: Core Experiment - Rigid Pavements (Non-Frost Areas) . . . . .         | III-27 |
| III- 5 - Data Collection Activities: Supplemental Studies - Flexible Pavements (Frost Areas) . . . . .     | III-28 |
| III- 6 - Data Collection Activities: Supplemental Studies - Flexible Pavements (Non-Frost Areas) . . . . . | III-29 |
| III- 7 - Data Collection Activities: Supplemental Studies - Rigid Pavements (Frost Areas) . . . . .        | III-30 |
| III- 8 - Data Collection Activities: Supplemental Studies - Rigid Pavements (Non-Frost Areas) . . . . .    | III-31 |

**LIST OF DATA SHEETS**

| <u>Data Sheet</u>   | <u>Page</u>   |
|---------------------|---|
| Data Sheet SMP-C01: | TDR Probe Check . . . . . II-43                                 |
| Data Sheet SMP-C02: | Thermistor and Air Temperature Probe Check . . . . . II-45      |
| Data Sheet SMP-C03: | Electrical Resistivity Probe Check . . . . . II-47              |
| Data Sheet SMP-C04: | Function Generator, Multimeter, and Switch Box Checks . II-48   |
| Data Sheet SMP-C05: | Tipping-Bucket Rain Gauge Calibration . . . . . II-51           |
| Data Sheet SMP-I01: | List of Installed Instrumentation . . . . . II-53               |
| Data Sheet SMP-I02: | Instrumentation Location . . . . . II-54                        |
| Data Sheet SMP-I03: | Log of Piezometer Hole . . . . . II-56                          |
| Data Sheet SMP-I04: | Log of Instrumentation Hole . . . . . II-58                     |
| Data Sheet SMP-I05: | Field Gravimetric Moisture Contents . . . . . II-60             |
| Data Sheet SMP-I06: | TDR Moisture Content . . . . . II-61                            |
| Data Sheet SMP-D01: | Manual Moisture Measurements . . . . . III-8                    |
| Data Sheet SMP-D02: | Manual Temperature Measurements . . . . . III-9                 |
| Data Sheet SMP-D03: | Contact Resistance Measurements . . . . . III-10                |
| Data Sheet SMP-D04: | Four-Point Resistivity Measurements . . . . . III-11            |
| Data Sheet SMP-D05: | Ground Water Table Measurements . . . . . III-13                |
| Data Sheet SMP-D06: | Joint Opening Measurements . . . . . III-14                     |
| Data Sheet SMP-D07: | Joint Faulting Measurements . . . . . III-16                    |
| Data Sheet SMP-D08: | Surface Elevation Measurements - AC Pavements . . . . . III-21  |
| Data Sheet SMP-D09: | Surface Elevation Measurements - PCC Pavements . . . . . III-22 |
| Data Sheet SMP-D10: | SMP Field Activity Report . . . . . III-33                      |



## I. INTRODUCTION

It is widely recognized that temperature, moisture and frost/thaw related changes in pavement structures, both within a day and over the course of a year, can have a significant impact on structural characteristics of pavement layers, thereby affecting response of the pavement to traffic loads, and ultimately the life of the pavement. However, the magnitude and relationship of these effects are not well understood, making them difficult to address with any degree of confidence in pavement design and evaluation.

To overcome this limitation, an endeavor referred to as the Seasonal Monitoring Program (SMP) has been undertaken within the long-term pavement performance (LTPP) study. The program's primary objective is to provide data needed to attain a fundamental understanding of the magnitude and impact of temporal variations in pavement response and material properties due to the separate and combined effects of temperature, moisture and frost/thaw variations. The products of this effort will provide (1) the means to link pavement response data obtained at random points in time to critical design conditions; (2) the means to validate models for relationships between environmental conditions (e.g., temperature and precipitation) and in situ structural properties of pavement materials; and (3) expanded knowledge of the magnitude and impact of the changes involved.

Resource limitations make it impossible to monitor on a seasonal basis all of the approximately 3,000 LTPP test sections scattered across North America. As a result, a two-tiered program has been established to maximize the number of sections studied and therefore, the applicability of the results. The first tier, referred to as the core experiment, includes 64 LTPP test sections selected to obtain a balance of key pavement factors: pavement type, thickness, environment, and subgrade type — see table I-1. The second tier, referred to as supplemental studies, was conceived in response to highway agencies desire to contribute by instrumenting and monitoring LTPP test sections not included among the core sites due to resource limitations. The final number of supplemental sections is not yet known.

The specific data to be collected under the SMP are summarized in table I-2, not excluding other data collected for LTPP purposes. Key elements of the monitoring plans include:

- Deflection basin testing for evaluating temporal variations in structural properties.  
Load transfer testing on joints and cracks in rigid pavements for monitoring load transfer conditions.  
Joint faulting and joint opening measurements for determining the effects of temperature variations on joint condition.

**Table I-1 - SMP Core Experiment: Experimental Design Cells and Target Number of Sections per Cell**

| Pavement Type                                 | Subgrade Soil | No Freeze |        | Freeze |        |
|---|---------------|-----------|--------|--------|--------|
|   |               | Dry       | Wet    | Dry    | Wet    |
| Flexible - Thin AC (< 127 mm (5 in)) Surface  | Fine          | 1 (3)     | 2 (3)  | 3 (3)  | 4 (3)  |
|   | Coarse        | 5 (3)     | 6 (3)  | 7 (3)  | 8 (3)  |
| Flexible - Thick AC (> 127 mm (5 in)) Surface | Fine          | 9 (3)     | 10 (3) | 11 (3) | 12 (3) |
|   | Coarse        | 13 (3)    | 14 (3) | 15 (3) | 16 (3) |
| Rigid - Jointed Plain Concrete (JPC)          | Fine          | 17 (1)    | 18 (1) | 19 (1) | 20 (1) |
|   | Coarse        | 21 (1)    | 22 (1) | 23 (1) | 24 (1) |
| Rigid - Jointed Reinforced Concrete (JRC)     | Fine          | 25 (1)    | 26 (1) | 27 (1) | 28 (1) |
|   | Coarse        | 29 (1)    | 30 (1) | 31 (1) | 32 (1) |

Notes: First number in each cell is the identification number assigned to the cell. The second number, in parenthesis, is the target number of sections for the cell.

**Table I-2 - SMP Data Elements**

| <b>DATA ITEM</b>   |
|--|
| <ul style="list-style-type: none"> <li>● <b>DEFLECTION DATA</b> <ul style="list-style-type: none"> <li>Deflection Basin                             <ul style="list-style-type: none"> <li>Mid-Lane (Flexible Pavements)</li> <li>Outer-Wheel Path (Flexible Pavements)</li> <li>Mid-Slab (Rigid Pavements)</li> <li>Edge: Corner or Centered on Crack (Rigid Pavements)</li> <li>Edge: Mid-Panel (Rigid Pavements)</li> </ul> </li> <li>Joint Load Transfer (Rigid Pavements)                             <ul style="list-style-type: none"> <li>Approach, Outer-Wheel Path</li> <li>Leave, Outer-Wheel Path</li> </ul> </li> </ul> </li> </ul> |
| <ul style="list-style-type: none"> <li>● <b>RELATED DATA</b> <ul style="list-style-type: none"> <li>Ambient Temperature and Rainfall</li> <li>Pavement Surface and Air Temperature</li> <li>Surface Layer Temperature Profile</li> <li>Moisture - Depth Profile</li> <li>Temperature - Depth Profile</li> <li>Depth of Frost/Thaw</li> <li>Depth of Ground Water Table</li> <li>Joint Opening (Rigid Pavements)</li> <li>Joint Faulting (Rigid Pavements)</li> </ul> </li> </ul>   |
| <ul style="list-style-type: none"> <li>● <b>ELEVATION AND PROFILE DATA</b> <ul style="list-style-type: none"> <li>Surface Elevation (Rod and Level)</li> <li>Longitudinal Profile (Profiler/Dipstick)</li> </ul> </li> </ul>   |
| <ul style="list-style-type: none"> <li>● <b>DISTRESS DATA</b> <ul style="list-style-type: none"> <li>Distress (Photographic/Manual)</li> </ul> </li> </ul>   |

- Surface elevation measurements for evaluating effects of frost heave and swelling soil.
- Transverse and longitudinal profile measurements for characterizing pavement rutting and roughness.
- Distress surveys for monitoring progression of pavement distresses over time.
- Ambient temperature and precipitation measurements for characterizing ground truth climatic conditions over time.
- Subsurface temperature and moisture content of the pavement layers for monitoring variation of these factors over time.
- Frost and thaw depth measurements, where applicable, for defining changes in support conditions over time.

The core experiment involves more frequent collection of pavement data than currently collected as part of routine LTPP monitoring. Additional data items collected which are not routine LTPP monitoring include surface elevation surveys; ambient temperature and precipitation measurements; and, subsurface moisture, temperature, frost/thaw depth and ground water table measurements. Monitoring guidelines for test sections in the supplemental studies are less rigorous than those for the core experiment, although agencies are urged to perform the full complement of core experiment monitoring measurements.

Collection of deflection, profile and distress data for the core experiment will be accomplished using existing LTPP equipment and testing protocols. This includes falling weight deflectometers (FWD's), profilers or alternate devices, photographic technology, and manual distress surveys. Where possible, profile and distress surveys on the supplemental studies sections will be conducted as part of routine LTPP testing. Deflection data for supplemental sections will be collected using highway agency forces and FWD's, which have successfully completed an FWD calibration process equivalent (as judged by FHWA-LTPP staff) to that implemented in the SHRP FWD regional calibration centers.

Instrumentation permanently installed at the test sections will gather the remaining data needed to quantify the impact of temporal variations in pavement response. Time-Domain Reflectometry (TDR) sensors and thermistors are used to monitor changes in subsurface moisture and temperature, electrical resistivity probes are used for frost/thaw depth measurements, and observation piezometers are used for ground water table depth determinations. In addition, air temperature probes and rain gauge tipping buckets are used to monitor ambient temperature and precipitation. All instrumentation needed for the core experiment sections of the SMP are procured by FHWA and provided to the Regional Coordination Office Contractors (RCOC's) for installation.

This document focuses on instrumentation installation and collection of data for the SMP. Section II presents information on instrumentation of seasonal test sections and includes a description of the sensors selected, detailed instrumentation installation guidelines, and detailed instrumentation operational guidelines. Data collection guidelines for the various

seasonal monitoring activities are presented in section III. The reader is referred to the following SHRP reports for additional information on development of the SMP:

"Experimental Design, Data Collection Plan, Site Selection Criteria, and Instrumentation Needs", February 1991.

"Instrumentation Needs for Core Experiment and State Supplements", May 1991.

"Data Collection Guidelines for Core Experiment and State Supplements", December 1991.



## II. SEASONAL MONITORING INSTRUMENTATION

### *INSTRUMENTATION OVERVIEW*

Instrumentation developed for the SMP will monitor changes in internal moisture content, surface and subsurface temperature, frost/thaw depth, depth to ground water table, and climate (ambient temperature and rainfall) over time. In selecting the instrumentation, a review of available literature was undertaken, and manufacturers were contacted to determine which sensors would best fit the needs of the program. After careful consideration, alternate sensor types were recommended and submitted to the SHRP In Situ Instrumentation Expert Task Group (ETG) for review. Because a consensus could not be reached, three pilot studies were initiated to explore installation techniques, costs, and relative effectiveness of alternate sensors — the first on a flexible pavement near Syracuse, New York; the second on a rigid pavement near Boise, Idaho; and the third on a flexible pavement near Billings, Montana.

Sensors at these sites were monitored at least monthly over a period of 6 months, and analysis of the data collected provided the basis for final recommendations: flat three-prong TDR probes for moisture measurements; thermistors for temperature gradient measurements; electrical resistivity probe for frost/thaw depth determinations; and observation piezometers to monitor ground water depth. Detailed descriptions of the sensors selected are provided next. The reader is referred to the following SHRP reports for information on instrumentation installation at the three pilot sites:

"Seasonal Testing Instrumentation Pilot: GPS 361011, IH 481 S.B., E. Syracuse, New York - October 22-25, 1991."

"Seasonal Instrumentation Pilot Study: Instrumentation Installation, Section 163023 in Idaho, November 5-7, 1991."

"Seasonal Instrumentation Pilot Study: Instrumentation Installation, Montana Section 308129, December 1992."

### Moisture Content Measurement

Moisture content of subgrade soil and unbound base/subbase layers is an important parameter in the study of pavement behavior; however, it is one of the most difficult to measure. Several methods for making moisture measurements exist, but each suffers from various limitations. The method selected for use in the SMP core experiment is time-domain reflectometry or TDR.

TDR equipment was originally developed for measuring electromagnetic wave travel times to detect breaks or shorts in electrical conductors, and has been adapted to measurement of soil moisture by agricultural researchers, primarily for irrigation purposes. The principle of the TDR system is similar to a radar system, in that an electromagnetic waveform is transmitted and the reflected waveform is recorded and analyzed to determine the distance and characterize the nature of objects which reflect the waves.

In the TDR method, the wave is transmitted along a shielded co-axial metallic cable which acts as a waveguide. The velocity of the pulse is influenced by the dielectric constant ( $\epsilon$ ) of material surrounding the conductors. The dielectric constant of a material is the ratio of a material's dielectric permittivity to the permittivity of a vacuum and is dimensionless. Changes in dielectric constant of the surrounding material, as well as, open or short circuits in the cable create wave reflections indicated by slope changes in the return wave pulse recorded by the TDR readout unit. A short circuit eliminates any return signals from beyond that point, while an open circuit results in a variety of return signals beyond that point.

Figure II-1 shows the TDR probe developed and fabricated by FHWA for use in the SMP. The co-axial lead cable center conductor is connected to the center of the three stainless steel rods, which are inserted in parallel into the soil to be monitored. The cable's outer shield is connected to the outer rods, and it becomes an electrical extension of the cable. The TDR readout device displays a rise and fall in the return signal strength as the electromagnetic wave enters the probe rods (initial inflection point), followed by a second rise or change in the return signal as the wave hits the end of the probes (final inflection point); as illustrated in figure II-2. The distance between the initial (Point D1) and final (Point D2) inflection point is known as the "apparent" length of the probe,  $L_a$ .

This technique works well in most soil applications because the dielectric constant of a soil is mostly a function of moisture content. The dielectric constant of water is approximately 80, while that of dry soils is normally between 3 and 5, depending on the soil type and density. Since water has such a large dielectric constant, it is the primary determinant of the dielectric constant for the soil-moisture-air mixture between the conducting surfaces of a TDR probe. The dielectric constant of a soil-water-air mixture is determined by comparing the "apparent" electrical length of the probe from the TDR signal to its actual length, as follows:

$$\epsilon = \left[ \frac{(L_a)}{(L)(V_p)} \right]^2 = \left[ \frac{(D_2 - D_1)}{(L)(V_p)} \right]^2 \quad (1)$$

- $\epsilon$  = dielectric constant (approximately 1.0 for air, 80 for water, and 3 to 5 for dry soil).
- $L_a$  =  $D_2 - D_1$  (see figure II-2); apparent length of probe, m.
- $L$  = 0.203 m (8 in) for FHWA probes (see figure II-1); actual length of probe units, m.
- $V_p$  = phase velocity setting on TDR cable tester (usually 0.99); this is the ratio of the actual propagation velocity to the speed of light.

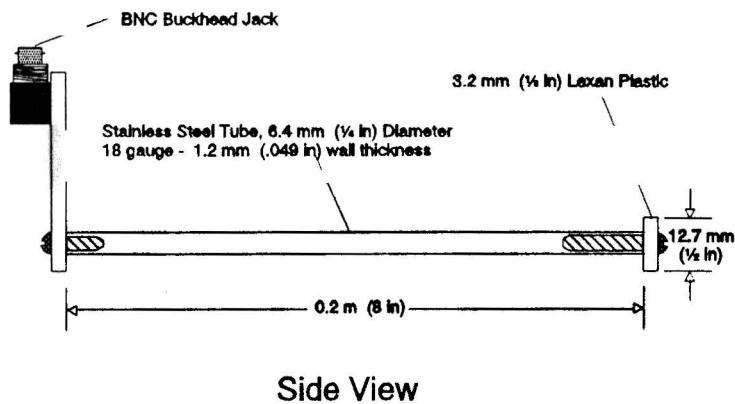
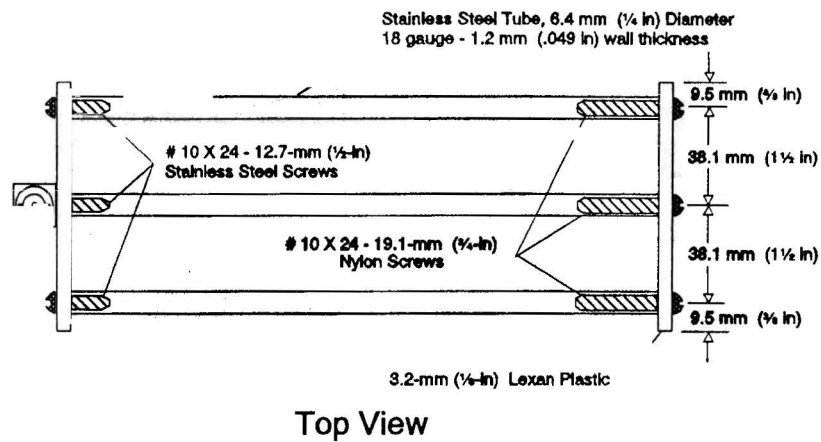

Note: 1 in = 25.4 mm

NOT TO SCALE

## FHWA Moisture Probe

Specifications for the FHWA Moisture Probe:

The center rod of the FHWA probe is connected to the signal lead of the coax cable. The other rods are connected to the shield of the coax cable. The probe connects directly to a 50 ohm RG58 coax cable. The end view shows the circuit board used to connect the 0.2 m (8-in) stainless steel rods to the coax cable.

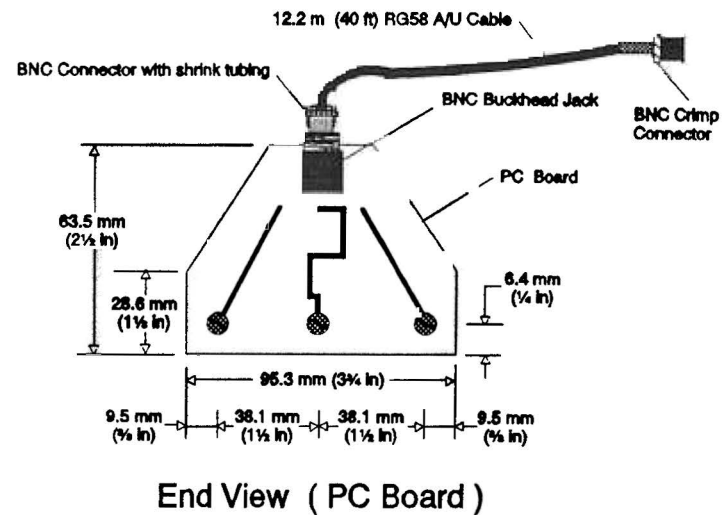

Figure II-1 - TDR Probe for SMP (developed by FHWA)

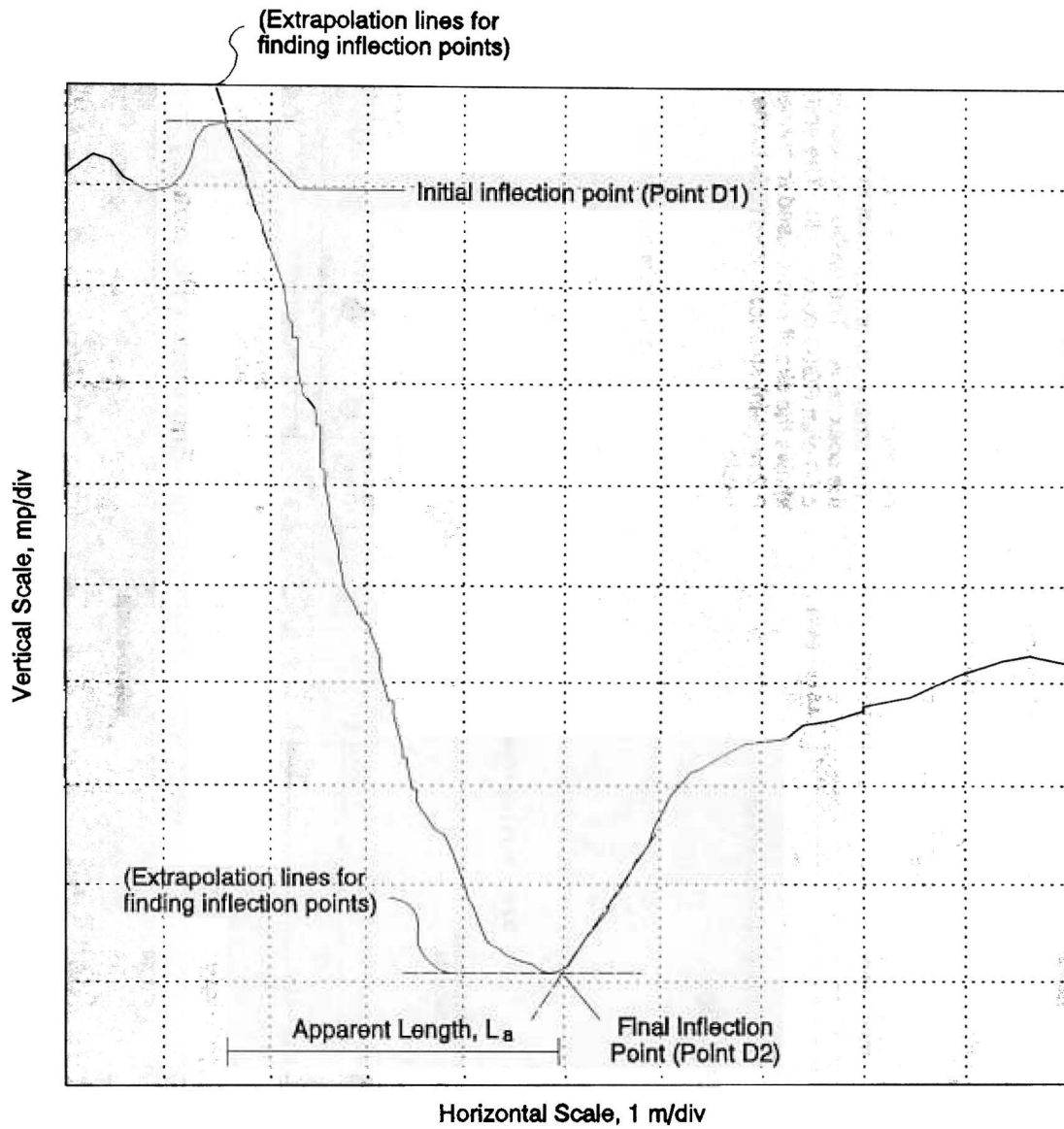

Figure II-2 - Typical TDR Signal

One problem experienced in saline or alkaline soils is that ions in the soil create an effective electrical short across the probe rods and make accurate interpretation of the trace difficult.

The volumetric moisture content is estimated from the measured dielectric constant using regression type equations or a theoretical formulation. Of these, Topp's equation (Topp, G.C., Davis, J.L., and Anna, A.P., "Electromagnetic Determination of Soil Water Content: Measurement in Coaxial Transmission Lines," Water Resource Research, 16(3) pp 574-582, 1980) will be used initially in the SMP to estimate the magnitude of moisture content change. Material samples will be collected to examine the accuracy of the Topp equation. Topp's equation, which is based on curve fitting of calibration data, is:

$$\theta = (-0.053 + 0.0293\epsilon - 0.00055\epsilon^2 + 0.0000043\epsilon^3) * 100 \quad (2)$$

where  $\theta$  = volumetric water content, in percent.

To convert soil moisture from a volume to weight basis, as needed in pavement engineering applications, the following equation is used:

$$w = \theta \frac{\sigma_w}{\sigma_d} \quad (3)$$

where  $w$  = gravimetric water content, in percent.  
 $\theta$  = volumetric water content, in percent.  
 $\sigma_w$  = unit weight of water, gm/cm<sup>3</sup> (= 1.0 gm/cm<sup>3</sup>).  
 $\sigma_d$  = dry density of soil, gm/cm<sup>3</sup>.

Reasonably accurate in situ dry density estimates of material surrounding TDR sensors must be made for moisture conversion. During installation, field moisture measurements should be performed on the material placed around TDR probes with additional material samples retained for laboratory analyses. These requirements are discussed later in the document under TDR installation guidelines.

## Temperature Measurement

The temperature sensor selected for the SMP is the thermistor. Thermistors are thermally sensitive resistors usually made of semiconductor material which has an extremely large temperature coefficient of resistance. Very small changes in temperature result in large changes in resistance (hundreds to thousands of ohms), which can be directly related to changes in temperature.

Thermistors are available in a variety of sizes and shapes; e.g., rods, disks, spheres, metal sheaths, glass beads, plastic coated, etc. For the SMP, the Measurement Research Corporation (MRC) TP101 thermistor probe will be used for temperature measurement through the pavement and into the subgrade. Each probe consists of three thermistor sensors in a 330 mm (13 in) long metal rod and a string of 15 thermistors encased in a 25-mm (1-in)

diameter by 1.81-m (6-ft) long clear rod (schedule 40 PVC pipe). Thermistors in the clear rod are mounted on a printed circuit board containing multiplexing circuitry. The metal rod with three sensors is installed in the pavement surface layer at an angle so that measurements at approximately 25 mm (1 in) deep, mid-depth, and 25 mm (1 in) above the bottom of the layer can be made on pavements up to 330 mm (13 in) thick. If the surface layer is over 330 mm (13 in) thick, the rod is placed vertically 25 mm (1 in) below the pavement surface. A schematic of the thermistor probe with thermistor sensors spacing is shown in figure II-3. A four-conductor 12.2-m (40-ft) lead cable provides connection to a temperature readout device or datalogger.

The resistance of each thermistor is found by applying a known voltage and reading the change in voltage across the thermistor's leads. The resistance reading is converted to temperature using a calibration equation. The calibration equation used in the SMP is Steinhart's model ("YSI Precision Thermistors," Yellow Springs Instruments, Yellow Springs, Ohio, 1979), which is given by the following equation:

$$\frac{1}{T} = C_1 + C_2 \ln R + C_3 (\ln R)^3 \quad (4)$$

where T = absolute temperature, Kelvin.  
 R = resistance, ohms.  
 C<sub>1</sub>, C<sub>2</sub>, C<sub>3</sub> = constants for individual thermistor.

The three constants are determined by regressing temperature versus resistance curves. Constants for the MRC TP101 probe are C<sub>1</sub> = 9.3441x10<sup>-4</sup>, C<sub>2</sub> = 2.2124x10<sup>-4</sup>, and C<sub>3</sub> = 1.2665x10<sup>-7</sup>, respectively.

Thermistors, like most other temperature sensors, do not indicate the temperature of the soil or pavement; they only indicate their own temperature. Hence, thermistors must be in close thermal contact with the medium whose temperature is being monitored. Further details on the thermistor probe installation and soil compaction around them are given later in this document.

## Frost/Thaw Depth Measurement

Temperature gradients have traditionally been used to determine depth of frost/thaw penetration into a soil. This method can be unreliable since deicing chemicals can depress the freezing point, and during thaw periods an isothermal temperature regime can exist to the maximum frost depth. Presently, the most reliable method to determine depth of frost/thaw penetration appears to be electrical resistance and resistivity measurements.

The electrical resistivity probe used in the SMP has 36 metal wire electrodes, spaced approximately 51 mm (2 in) apart and mounted on a solid PVC rod 1.9 m (73 in) long. Individual lead wires connected to each electrode run inside the rod which is sealed with

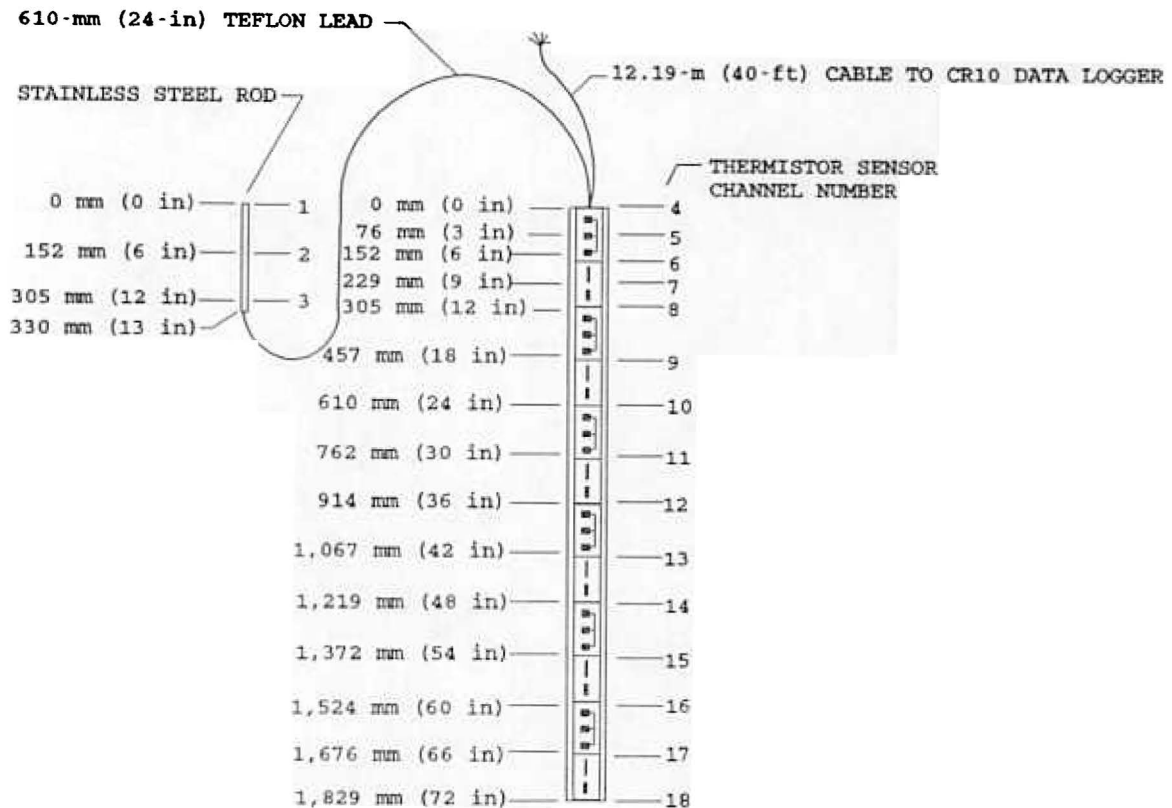

**NOTES:**

**Dimensions:**

Probe: 1,829 mm x 25 mm (72 in x 1 in) OD  
 External Sensors: 330 mm x 6 mm (13 in x 1/4 in) OD

**Model TP101**

Manufactured by Measurement Research Corporation  
 Total of 18 Thermistors  
 Degree of accuracy +/-0.1 degree C  
 External 330 mm (13 in) Lead attached by 610 mm (24 in)  
 of Teflon Wire  
 76 mm (3 in) spacing from 0.0 mm (0 in) to 305 mm (12 in)  
 and 152 mm (6 in) spacing from 305 mm (12 in) to 1,829 mm  
 (72 in) and for the External Lead

**Figure II-3 - Thermistor Probe for SMP (manufactured by MRC)**

potting compound. The lead wires are 12.2 m (40 ft) long from the probe to a DB37 pin connector. Figure II-4 illustrates the electrical resistivity probe used in the SMP. These probes have been developed by the U.S. Army Corps of Engineers' Cold Regions Research and Engineering Laboratory (CRREL) and are manufactured by ABF Manufacturing, Inc.

Electrical resistivity of most soil minerals is very high and for practical purposes can be considered infinite, and virtually all electrical current flow through a soil is carried by free ions in the pore water. Thus, the electrical resistivity of soil depends primarily on its porosity, degree of pore water saturation, and electrical resistivity of the pore water. Because the electrical resistivity of ice is much greater than that of unfrozen pore water, formation of ice in the pore space causes a net decrease in effective porosity and a corresponding increase in apparent or bulk electrical resistivity. Therefore, in addition to determination of frost/thaw depth, electrical resistivity measurements can indicate changes in moisture content.

Electrical resistance can be measured with an ohmmeter or ohmmeter function of a multi-purpose electrical meter (called multimeters). An ohmmeter works by injecting an electrical current (I) through a specimen and measures the resulting voltage drop (V) across the specimen. Electrical resistance (R), voltage and current are related to each other according to Ohm's law as:

$$R = \frac{V}{I} \quad (5)$$

where  $R$  = electrical resistance, ohms ( $\Omega$ ).  
 $V$  = voltage, volts (V).  
 $I$  = current, amperes (A).

For a material of uniform cross section, electrical resistance measured over its length is related to the geometry of the material body as:

$$R = \rho \times \left[ \frac{L}{A} \right] \quad (6)$$

where  $R$  = electrical resistance, ohms ( $\Omega$ ).  
 $\rho$  = electrical resistivity of the material, Ohmmeters.  
 $L$  = length of the material, meters.  
 $A$  = cross sectional area of the material, meters<sup>2</sup>.

Electrical resistivity is a material property, whereas measured contact (electrical) resistance is a function of electrical resistivity of the material, geometry of the body, and quality of contact between the electrodes and the material. Electrical resistivity values can be numerically related to soil properties, while contact resistance only provides a qualitative indication of these properties.

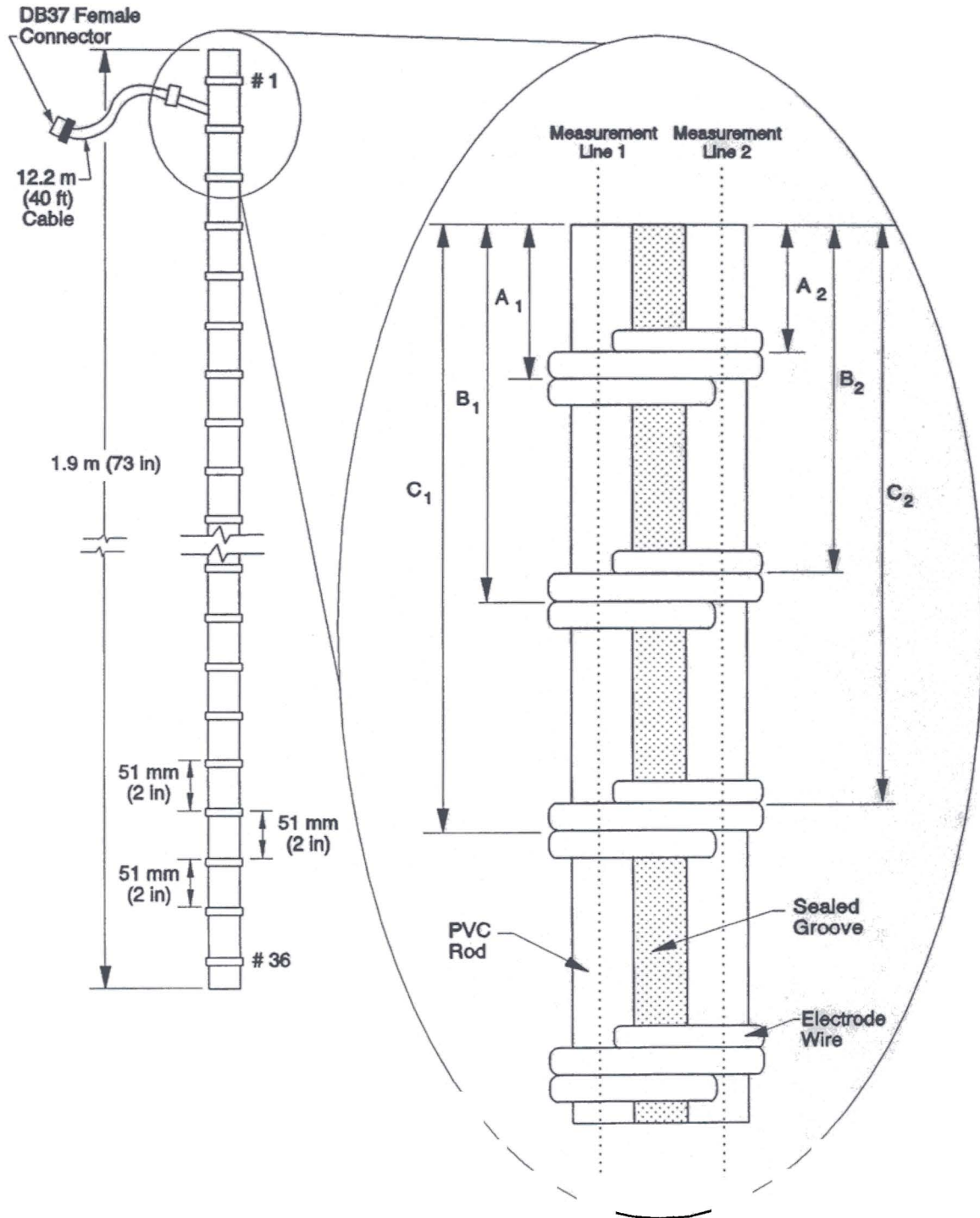

Figure II-4 - Resistivity Probe for SMP (developed by CRREL)

To measure electrical resistance or resistivity of soil, a function generator is used to supply a low frequency alternating current (AC) to minimize polarizing effects on ions in the pore water. Low frequencies (approximately 100 Hz) avoid inductive and AC coupling effects, and direct current resistance and resistivity equations can be used without loss of accuracy.

For the SMP electrical resistivity probe, contact resistance is calculated from the electrical current transmitted through two adjacent electrodes and the measured voltage across the electrodes. Current and voltages are measured for each adjacent electrode pair sequentially down the probe. Function generator and multimeter connections for contact resistance measurement are illustrated in Figure II-5. Equation 5 is used to compute contact resistance, and they are plotted as a function of depth for the electrode pairs. The location of frost is determined by comparing the "unfrozen" electrical resistance profile against the "frozen" profile. Frost areas are identified by relatively large increases in electrical resistance. The temperature profile is generally plotted adjacent to the electrical resistance profile to aid interpretation.

Electrical resistivity measurements are made using a four-electrode technique in which current is input to two outside electrodes and voltage drop is measured across two inside electrodes. This technique avoids polarization reactions which occur at the current electrodes on voltage measurements. It also increases the volume of material surrounding the electrodes being measured. With the four point measurement technique, apparent or bulk electrical resistivity of the material surrounding the electrodes can be computed as:

$$\rho = G \times \left[ \frac{V}{I} \right]$$

- where  $\rho$  = bulk electrical resistivity, ohmmeter.  
 $G$  = geometric factor for the electrode array, meters.  
 $4\pi a$ , for LTPP type of sensor.  
 $a$  = uniform spacing between electrodes, meters.

If spacing between electrodes is not uniform, the following equation is used to compute the value of  $a$  in Equation 7:

$$a = \frac{1}{\frac{1}{S_1} - \frac{1}{S_1+S_3} - \frac{1}{S_1+S_2} + \frac{1}{S_3}}$$

- where  $S_1$  = spacing between the first and second electrode, meters.  
 $S_2$  = spacing between the second and third electrode, meters.  
 $S_3$  = spacing between the third and fourth electrode, meters.

Function generator and multimeter connections are shown in Figure II-5(B) for apparent electrical resistivity measurement. Connections are sequentially moved to the next lower electrode for each measurement. The electrical resistivity is computed using the above

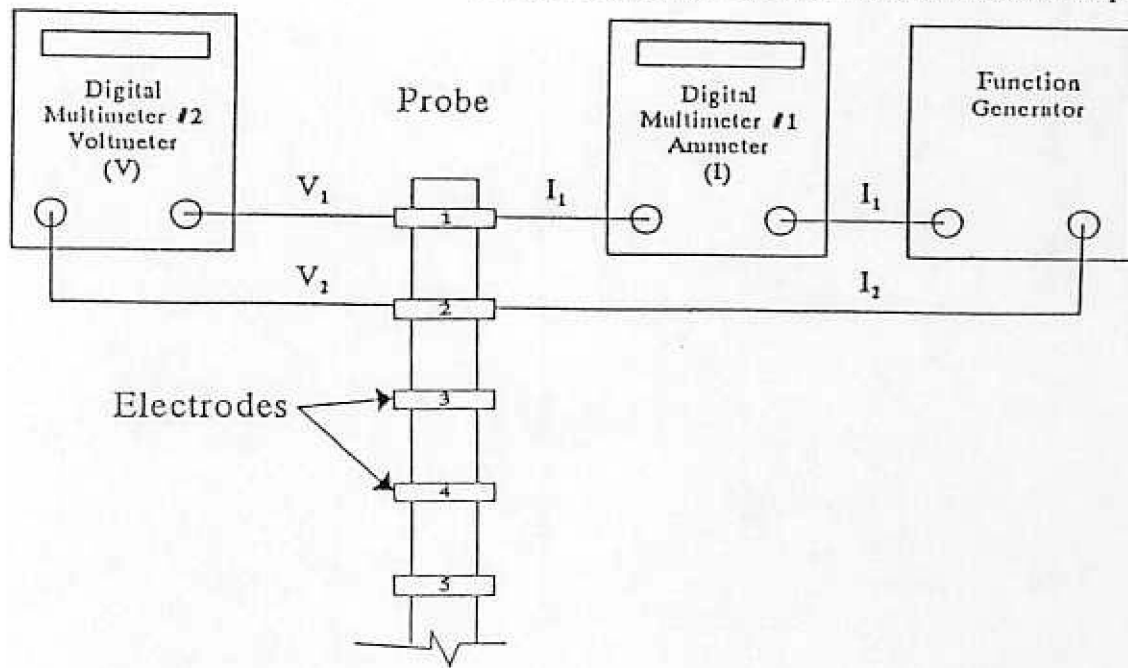

(A) Contact (Two Point) Resistance Measurement.

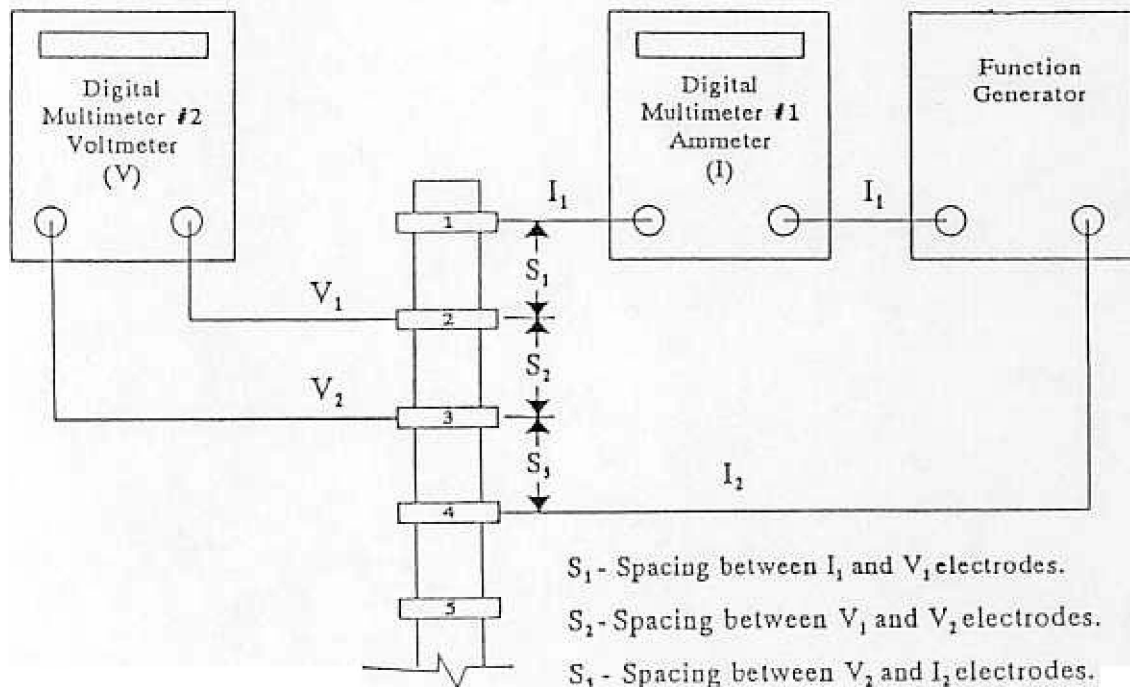

(B) Four Point Resistivity Measurement.

Figure II-5 - Electrical Resistance Measurements - CRREL Probe

equations, and they are plotted against depth of mid-point between the two voltage electrodes. Interpretation of frost locations can be performed similar to that for contact resistance. This technique also permits use of a moisture content calibration equation to estimate changes in moisture.

## Ground Water Depth Measurement

Depth of ground water table will be measured through an observation piezometer. The observation piezometer can also serve as a frost- and swell-free benchmark for surface elevation measurements, unless another permanent benchmark is established. The observation piezometer for the SMP consists of two galvanized steel pipes, approximately 4.4 m (14.5 ft) combined length and 25 mm (1.0 in) in diameter. The bottom 457 mm (18 in) of the pipe is slotted and wrapped with filter cloth. The top 2.1-m (7.0-ft) section of pipe is covered with a 1.5-m (5.0-ft) outer pipe sleeve, approximately 32 to 38 mm (1.25 to 1.5 in) in diameter. The space between the pipe and the outer sleeve is filled with waterproof grease. The bottom of the pipe is threaded to a metal floor flange or a three-prong anchor (Geonor point; as used on Borros Type heave settlement points), which acts as an anchor. Figure II-6 illustrates the observation piezometer just described; details on piezometer installation are given later in the document. For seasonal test sections that have ground water within 1.5 m (5 ft) of the surface, a submersible pressure transducer may be installed to automatically measure changes in water table depth with time. Also, for sites with frost in excess of 1.5 m (5 ft), the overall length of the piezometer stays the same, but the top section of pipe is increased to 3 m (10.0 ft) and outer pipe sleeve to 2.4 m (8 ft).

## Climatic Measurements

Air temperature and rainfall will be measured in the SMP using an air temperature probe and a tipping-bucket rain gauge on a pole next to the site equipment cabinet. The pole assembly consists of a 51 mm (2 in) galvanized steel pipe, at least 4.3 m (14 ft) in length with a 0.3 m (1 ft) extension arm, 44 mm (1.75 in) in diameter, at a height of 2.7 m (9 ft). (Note: it is critical the rain gauge be placed vertical). Figure II-7 illustrates the equipment cabinet and pole assembly.

The air temperature probe, manufactured by Campbell Scientific, Inc., consists of a temperature sensor and radiation shield. The Model #107 thermistor probe used for the SMP has a temperature range from -35 to 50 °C (-31 to 122 °F). The solar radiation shield Model #107-L protects the temperature probe from various environmental conditions. The temperature probe and shield are mounted to the extension pipe with clamps for the 44-mm (1.75-in) diameter extension arm (see figure II-7).

The tipping-bucket rain gauge (Model # TE525MM), manufactured by Texas Electronics, measures rainfall in 0.1-mm (or 0.004-in) increments. When rain reaches a calibrated level, the bucket tips actuating a switch, and switch-pulses are counted by the onsite datalogger (see

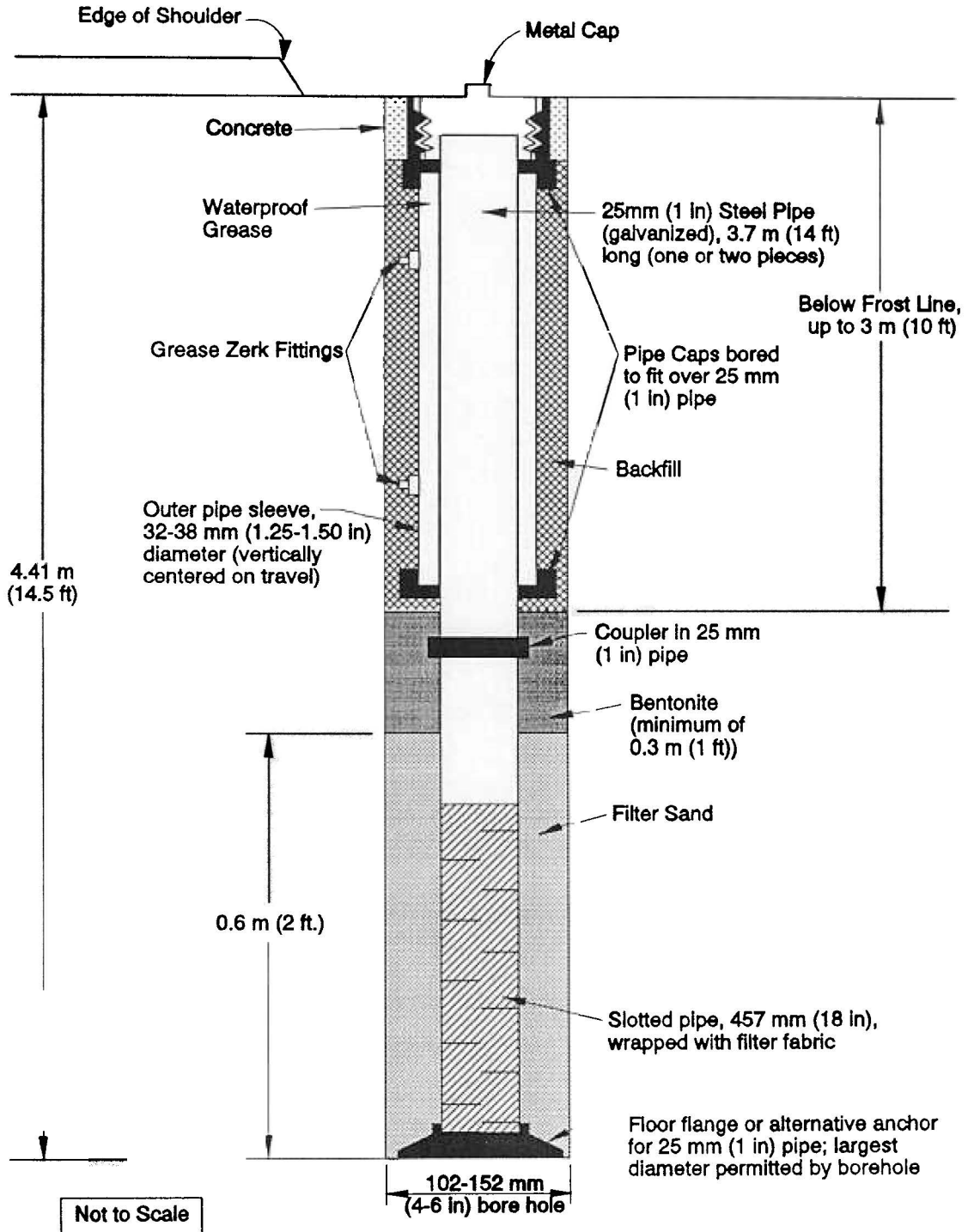
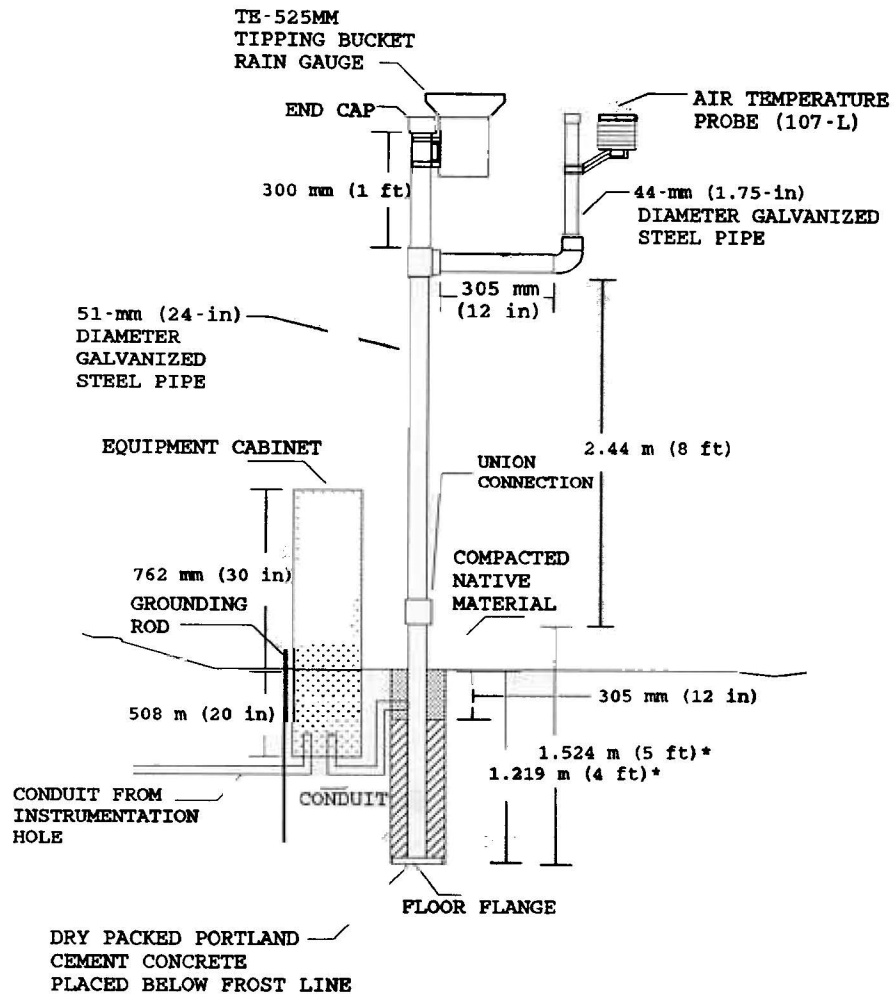

Figure II-6 - Observation Piezometer for SMP



**NOTES:**

Wire from the Rain Gauge and Temperature Probe will be placed through the inside of the pipe.

Wire will be taped around curved sections of the pipe to prevent any shorting of the instrumentation.

Silicon will be placed where the wires from the instrumentation go into the pipe.

The equipment cabinet and the pole assembly should be a breakaway unit.

Base of cabinet filled with pea rock.

\* These lengths should be made to extend below expected frost depth.

**Figure II-7 - Rain Gauge and Temperature Probe for SMP**

next section on other equipment). Once the bucket tips, water funnels out through the base of the gauge. The rain gauge is mounted on the main pole assembly with two 76-mm (3-in) diameter pipe clamps (see figure II-7).

## Other Related Equipment

In addition to the sensors described, other equipment at each seasonal monitoring site includes an equipment cabinet, mobile recording equipment, onsite recording equipment, and manual measurement equipment.

### Equipment Cabinet

An equipment cabinet or telephone pedestal (Model # CAD 12PT), manufactured by Reliable Electric/Utility Products, is used to house cable leads and onsite recording equipment — onsite CR10 datalogger, electrical relay and battery pack.

### Mobile Recording Equipment

Mobile recording equipment includes a Tektronix 1502B Cable Tester and a mobile recording unit. The Tektronix 1502B Cable Tester is used for TDR measurements. This is a short-range metallic cable tester capable of finding faults in metal cables (i.e., it sends an electrical pulse down the cable, and detects reflections from discontinuities). For the cable tester to communicate with the mobile recording unit, the following modules developed by Campbell Scientific are used:

- SDM1502 - This communication interface plugs into the 1502B and provides a synchronous interface through the SDMX50 multiplexers to the CR10 datalogger.
- PS1502B - Power control module plugs into the battery receptacle of the 1502B and connects to the CR10 datalogger to control power to the 1502B.

The mobile recording unit consists of the following instruments available from Campbell Scientific:

- SDMX50 Multiplexers - Two SDMX50 multiplexers are used in the mobile unit to switch between the TDR probes. The SDMX50 is an eight-to-one 50 ohm coax multiplexer with BNC connectors. A 6517 coax cable from the 1502B connects to the common port on level 1. TDR probes 1 through 7 are connected to level 1 SDMX50 multiplexer. A 50 ohm coax link (L) 6633 cable connects the common on level 2 multiplexer to location 8 on level 1 multiplexer. The remaining three TDR probes (8, 9 and 10) are connected to positions 1-3 of level 2 multiplexer.

- 6517 Cable - 1.5 m (5 ft) 50 ohm coax cable for connecting TDR cable reader to level 1 SDMX50 multiplexer.
- 6549 Cable - 5 conductor cable used for SDM connection between datalogger and multiplexers.
- 6633 Coaxtor Link - 0.9 m (3 ft) 50 ohm cable used to link level 1 and 2 SDMX50 multiplexers.
- CR10 Datalogger/Controller - The datalogger, equipped with LSG 720 TDR prom, communicates with the 1502B and SDMX50 multiplexers using control ports 1-3. Control port 4 switches power to the 1502B.
- LSG 720 TDR Prom - Replaces 0S10 prom in the CR10 datalogger and includes instruction 100 for controlling the 1502B and SDMX50 multiplexers.
- PS12A Power Supply - 12 VDC power supply with charger. This unit powers the 1502B, SDM1502, CR10, and two SDMX50.

The mobile recording unit also contains an automated multiplexer constructed by CRREL for contact resistance measurements.

The mobile data recording unit is housed in a rugged carrying case and wired as shown in figures II-8 and II-9. The diagram in figure II-8 shows SDM communicator cables from the SDM1502 communication interface, SDMX50 multiplexers connections to the CR10, and power supply connections to the CR10. This figure also shows the hookup for the coaxial cable from the 1502B to the level 1 multiplexer, the coax link to the level 2 multiplexer, and the 10 TDR moisture probe connections. Layout of the mobile recording unit is depicted in figure II-10.

The CR10 is programmed to record waveforms for the 10 TDR probes and voltage measurements from the electrical resistivity probe. Communication to the datalogger is handled by the PC 208 datalogger support software. A notebook computer is used to download the control programs to the CR10, monitor activity of the CR10, and upload data to the computer from the CR10. A SC32A optically isolated RS232 connector is required to interface the CR10 to the notebook computer. A DB25M/F extension cable can be used to access the CR10 from a vehicle parked on the shoulder of the road.

### Onsite Recording Equipment

Onsite recording equipment is panel mounted inside the equipment cabinet, and consists of a CR10 datalogger, a Crydom D1D07 SPST solid state relay, a battery power supply, and a terminal wiring strip. The wiring diagram is illustrated in figure II-11, which also shows connections for optional vibrating type piezometer probe and resistivity probe readers.

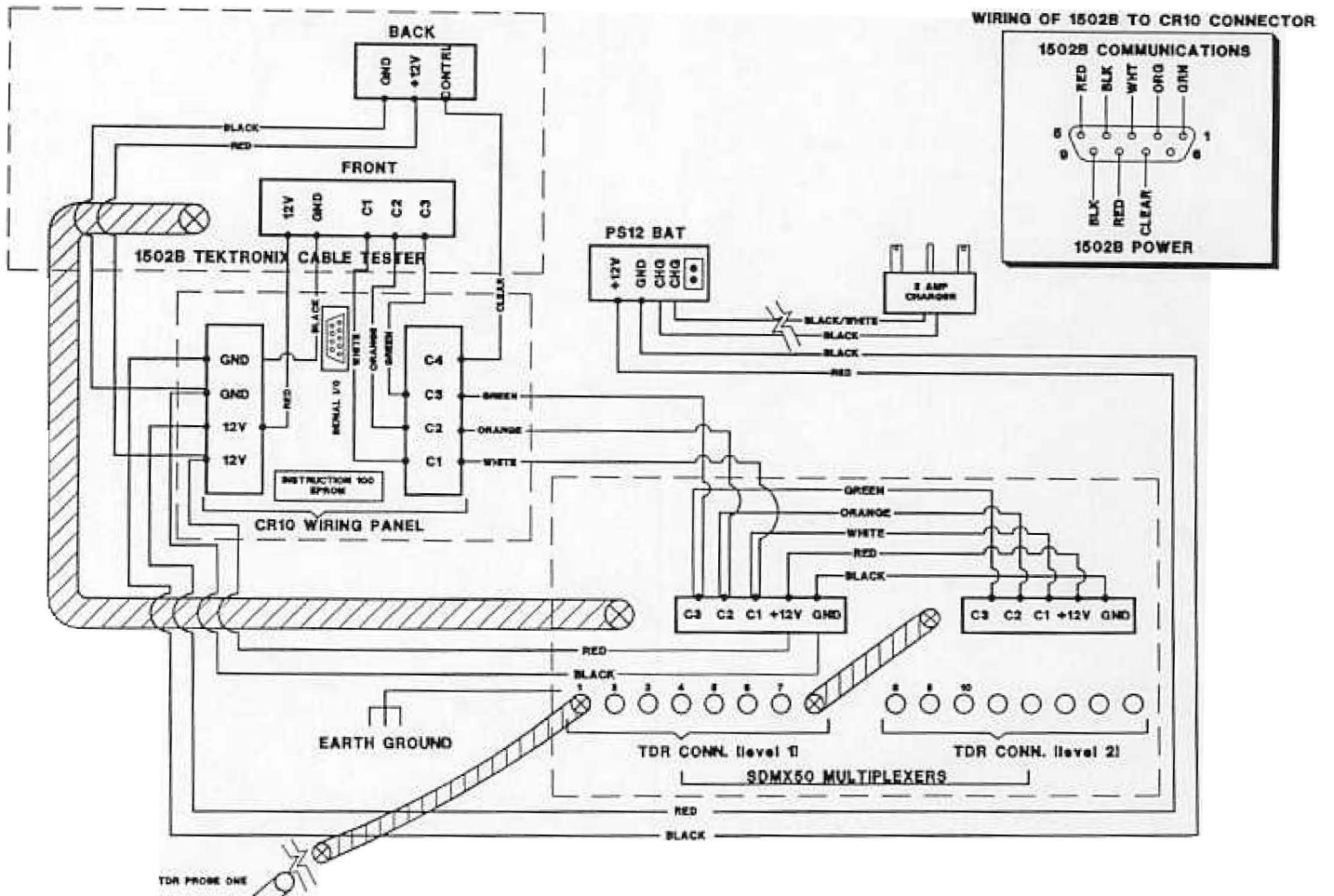

Figure II-8 - Wiring Diagram for TDR System

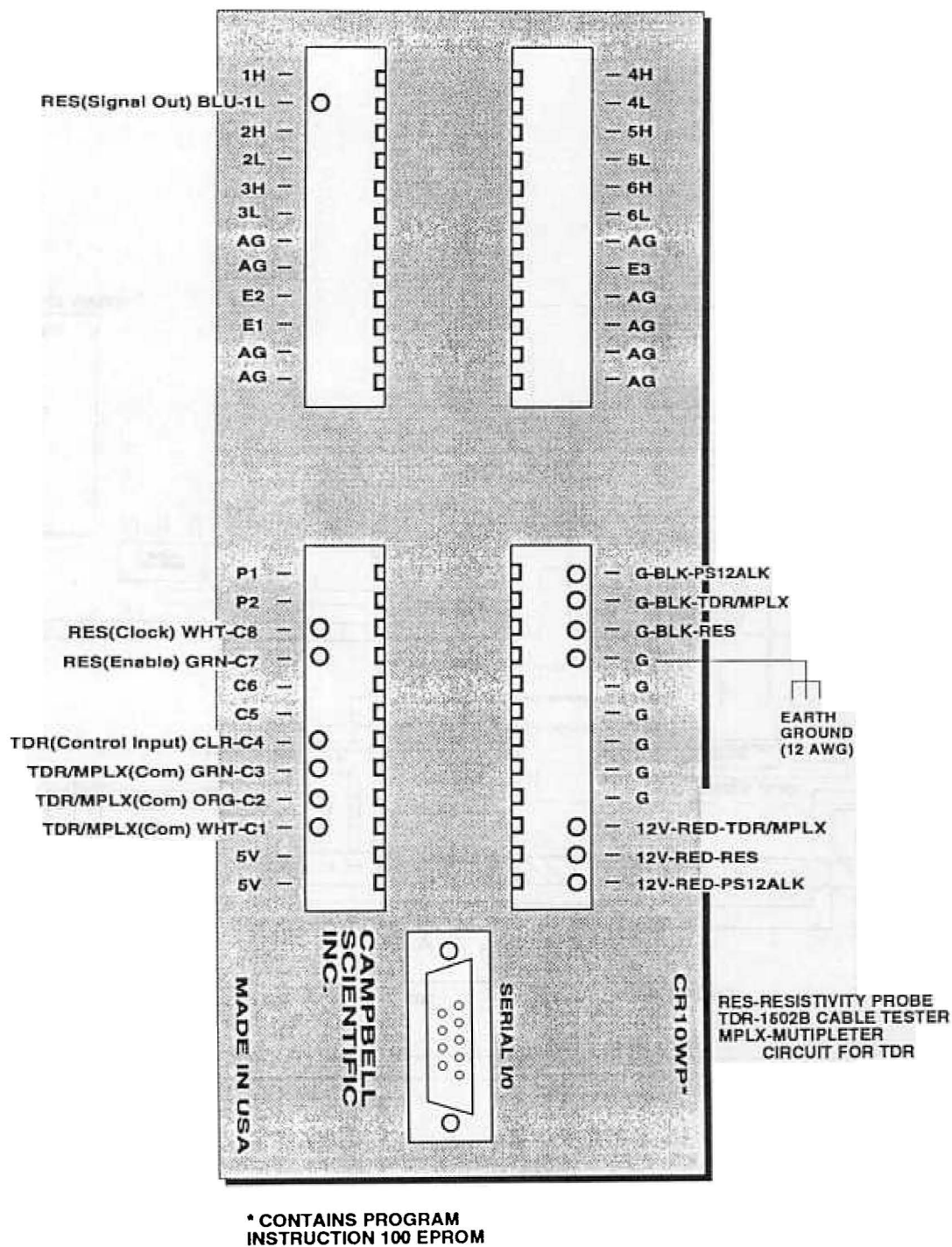

Figure II-9 - Wiring Diagram for Mobile CR10 Datalogger



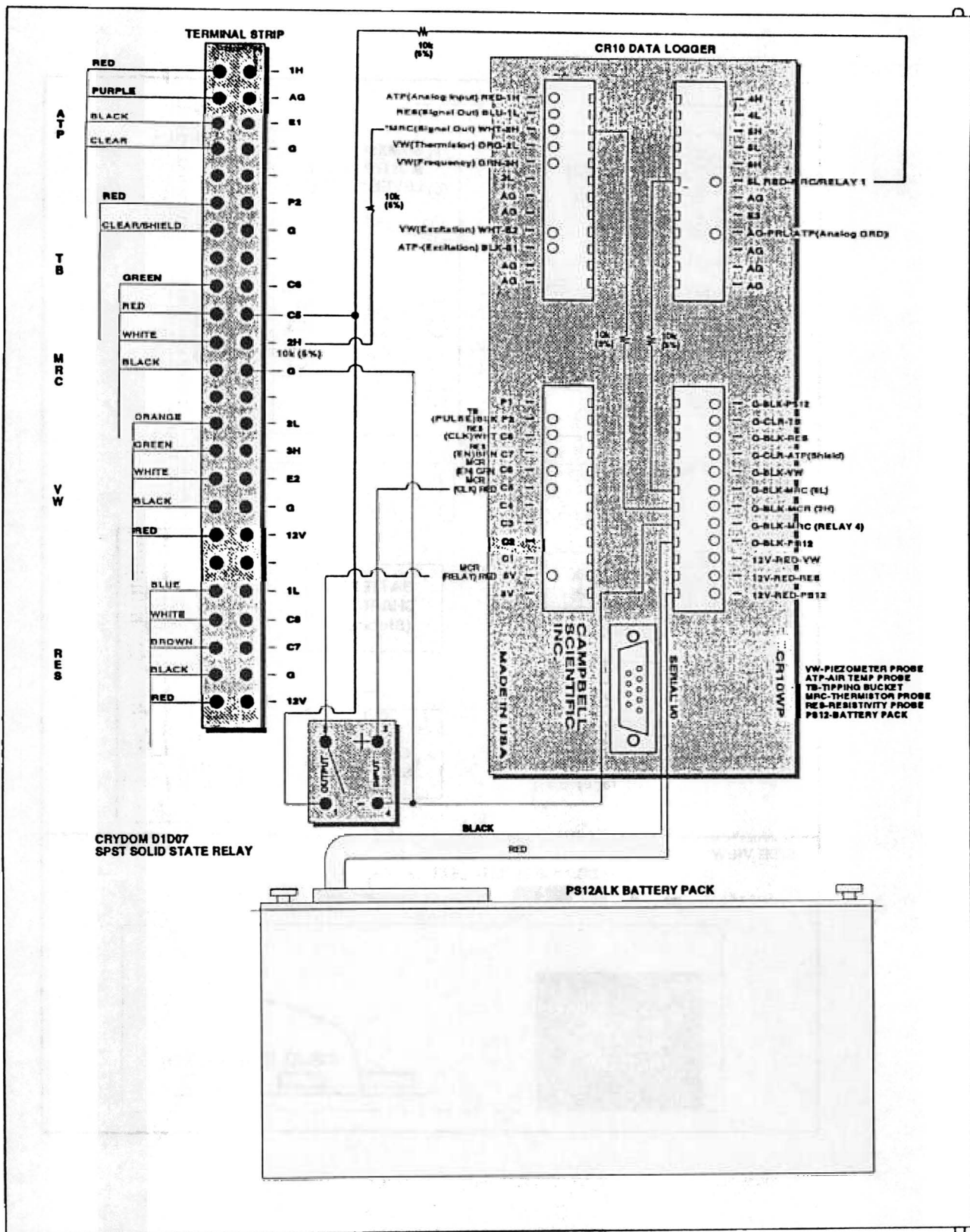

Figure II-11 - Wiring Diagram for Onsite CR10 Datalogger

The onsite datalogger provides hourly/daily records of the 107-L air probe, MRC TP101 thermistor probe, and TE525 tipping bucket. For a few select sites, the electrical resistivity probe (frost/thaw zones) and vibrating wire (water table) will be connected.

The datalogger is powered by a PS12A power supply using a YUASA gel cell battery. The datalogger provides sequential measurements of the 18 thermistors in the TP101 probe and converts output voltages to temperature using the Steinhart equation. The CR10 datalogger also reads the 107-L air temperature probe on a 1-min cycle and records switch pulses from the TE525 tipping bucket as they occur.

Communication between the datalogger and notebook computer uses the same hardware as the mobile recording system. The software program, called ONSITE, controls the CR10, and it is described under "Instrument Operational Guidelines" later in this document.

### Manual Measurement Equipment

In addition to mobile and onsite automated measurements, manual backup readings can be made for all sensors except the air temperature probe and rain gauge devices. Also, manual equipment is used for field moisture determination during TDR installation. The following equipment is required for manual measurements:

- Equipment to perform subsurface moisture measurements:

The Tektronix 1502B cable tester with YT-1 strip chart recorder is capable of providing printed waveform traces for each probe. Manual traces are obtained during TDR installation and when problems occur with the automated system. The 1502B may be operated from either a 115 VAC, or 230 VAC line, or the internal battery pack. In manual mode, the internal battery pack and YT-1 strip chart recorder are used in place of the PS1502B power module and the SDM1502 communication interface. The TDR traces printed from the strip chart are manually interpreted. AC power can be used to monitor TDR waveforms, but DC power should be used to print traces to avoid problems with "noise" from DC/AC inverters or generators. (Note: AC power from the FWD tow vehicle's inverter has been known to cause "noise" in the printed traces).

Further details regarding technical and operational aspects of this device are provided in the Tektronix "1502B Metallic Time Domain Reflectometer Operator Manual."

- Equipment to perform gravimetric moisture content measurement in the field:

Manual balance with a minimum capacity of 2,000 g and an accuracy of 0.1 g.

Camp stove with adjustable flame and fuel supply.

Ten metal pans to weigh and dry soil and base material.

Twenty soil moisture sample containers per site. These may be zip lock plastic bags or plastic sample jars.

- Equipment to perform subsurface temperature measurements:

A model RD100 or RD200 hand-held temperature readout unit provides manual readout of the TP101 probe, both as a back up to the automated procedure and to check operation of the probe prior to installation. These units are connected to the TP101 using a color-coded test lead jig assembly. The RD100 unit is accurate for the temperature range between  $-12\text{ }^{\circ}\text{C}$  ( $10\text{ }^{\circ}\text{F}$ ) to  $11\text{ }^{\circ}\text{C}$  ( $52\text{ }^{\circ}\text{F}$ ) and the RD200 unit is accurate for the temperatures range between  $-40\text{ }^{\circ}\text{C}$  ( $-40\text{ }^{\circ}\text{F}$ ) to  $65\text{ }^{\circ}\text{C}$  ( $149\text{ }^{\circ}\text{F}$ ).

- Equipment to perform frost/thaw depth measurements:

A function generator capable of supplying a square wave signal at 100 Hz with 10V (p-p) output into  $600\Omega$  or equivalent. A Simpson type 420D-120 function generator has been used and found to be satisfactory. This model is capable of operating from 4-C size rechargeable batteries. Other function generators which require external 120VAC power like the BK Precision Type 3010 and Beckman Industrial Type FG2A function generators can be used.

Two digital multimeters — One meter is used to measure AC currents as low as  $.2\ \mu\text{A}$ , and the other meter to read AC voltages as low as  $.2\ \text{mV}$ . These readings can be achieved with  $3\frac{1}{2}$  digit multimeters with 200 mV range and 200  $\mu\text{A}$  range. Heavy duty multimeters enclosed in durable, water proof and drop proof enclosures should be used. Non-ruggedized multimeters will require greater care.

Manual switch box with connectors for the function generator, digital multimeters and electrical resistivity probe. The switch box allows switching connections of the  $I_1$ ,  $I_2$ ,  $V_1$ , and  $V_2$  leads as shown in figure II-5. This set-up is a back up to automated voltage readings for contact resistance and provides the only means for performing four-point electrical resistivity measurements.

## ***INSTALLATION GUIDELINES***

### **Installation Layout**

The layout for a typical seasonal monitoring instrumentation installation is illustrated in figure II-12. TDR probes, thermistor probe, and electrical resistivity probe are placed in one hole located in the outer wheel path as defined in the LTPP Manual for FWD Testing (approximately 0.76 m (2.5 ft) from the outside edge of white stripe on most sites) and at least (but preferably more than) 1.2 m (4 ft) away from joints and/or cracks to avoid unrepresentative surface moisture infiltration. Figure II-13 illustrates sensor layout in the instrumentation hole. The instrumentation hole extends approximately 2.1 m (7 ft) beneath the bottom of the bound pavement layers.

The top of the thermistor and electrical resistivity probes are placed approximately 51 mm (2 in) below the bottom of the lowest stabilized layer to minimize potential damage from traffic applications. The 10 TDR probes are placed at the following depths (in reverse order of installation; see figure II-13):

If the top granular base (or subbase) layer is greater than 305 mm (12 in), the first TDR probe (from top to bottom) is placed 152 mm (6 in) below the bottom of the lowest stabilized layer. Otherwise, the probe is placed at mid-depth of the top granular base (or subbase) layer. This probe may need to be turned upside down so that the top of the circuit board does not touch the bottom of the bound layers.

- The next seven TDR probes (from top to bottom) are placed at 152 mm (6 in) intervals, while the last two probes are placed at 305 mm (12 in) intervals.

Wires from the instrumentation hole are placed in a 51 mm (2 in) diameter flexible steel conduit and buried in a 76 mm (3 in) wide trench leading to the equipment cabinet. The equipment cabinet and climatic sensors (rain gauge and temperature probe) are located approximately 9 m (30 ft) from the edge of the travel lane. In addition, the observation piezometer/frost free bench mark is placed just outside the paved shoulder at a station approximately midway between the first and last FWD seasonal test points. A cross-sectional view of the observation piezometer was presented in figure II-6.

### **Roles and Responsibilities**

Instrumentation installation must be a cooperative effort between all participants in the SMP — participating highway agency, respective RCOC, and FHWA-LTPP Division. Tables II-1 and II-2 summarize roles and responsibilities of each participant for the core experiment and supplemental studies, respectively. Further comments regarding these roles and responsibilities are provided below:

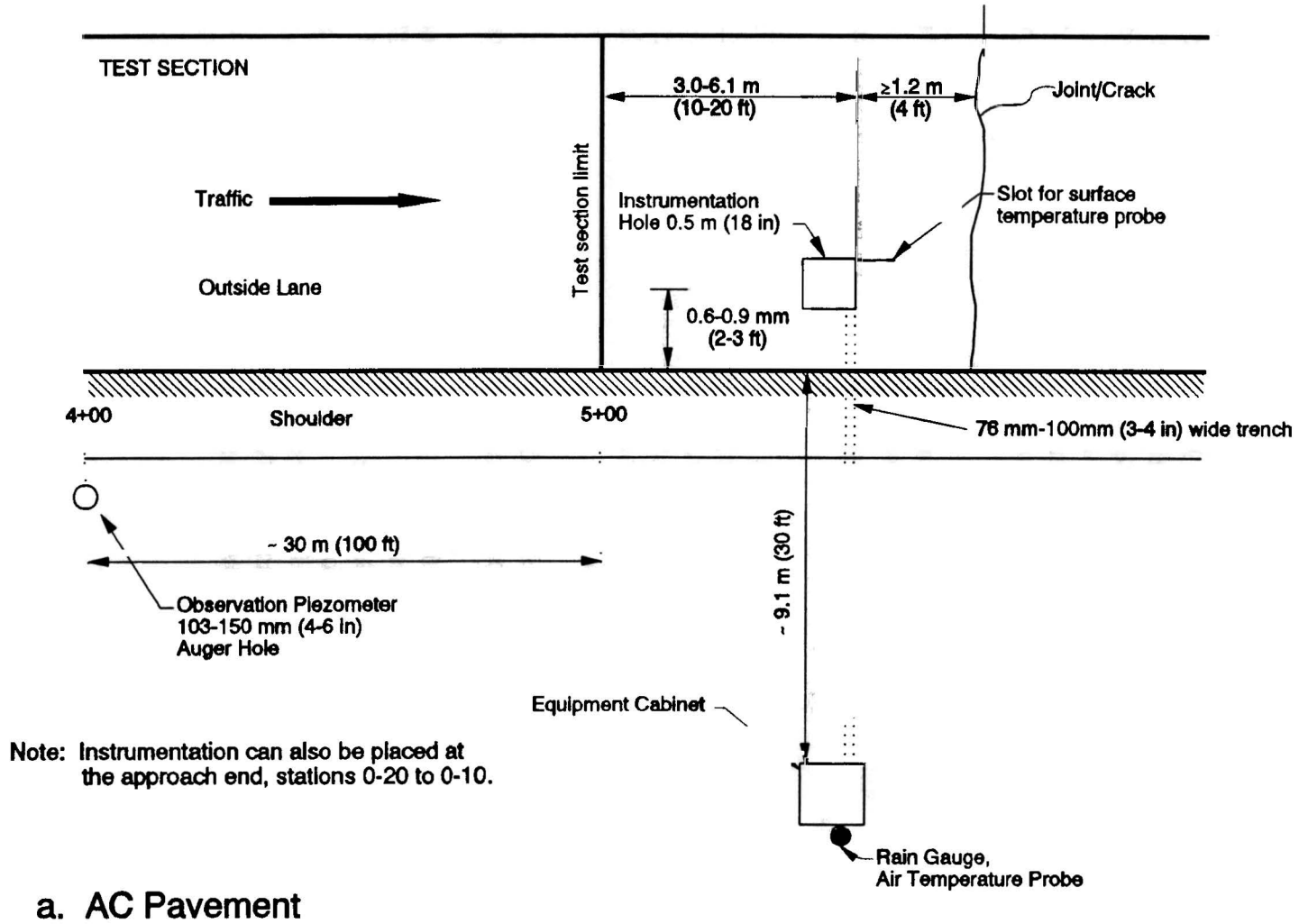
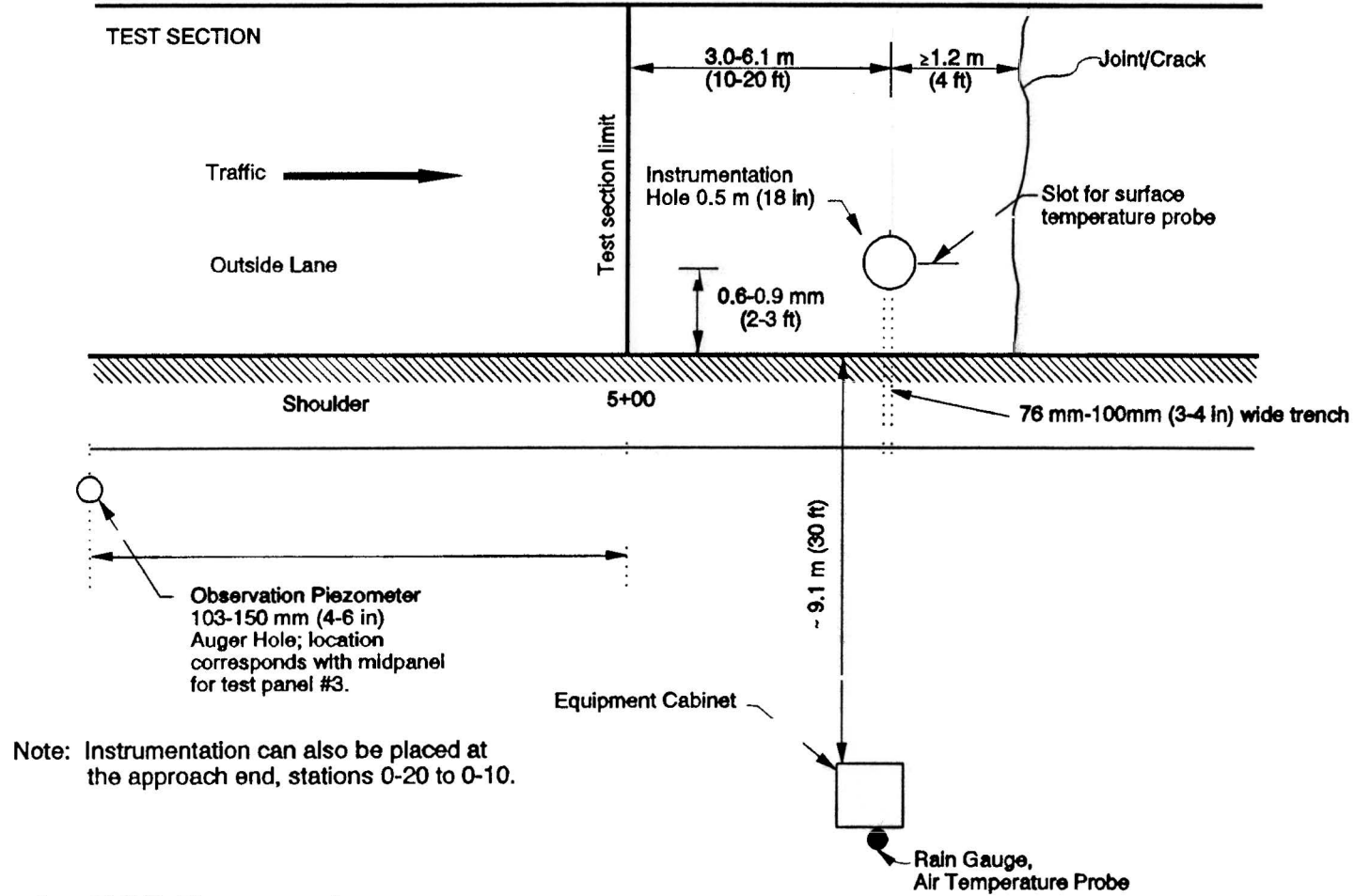

Figure II-12 - Typical Instrumentation Layout



b. PCC Pavement

Figure II-12 - Typical Instrumentation Layout (Continued)

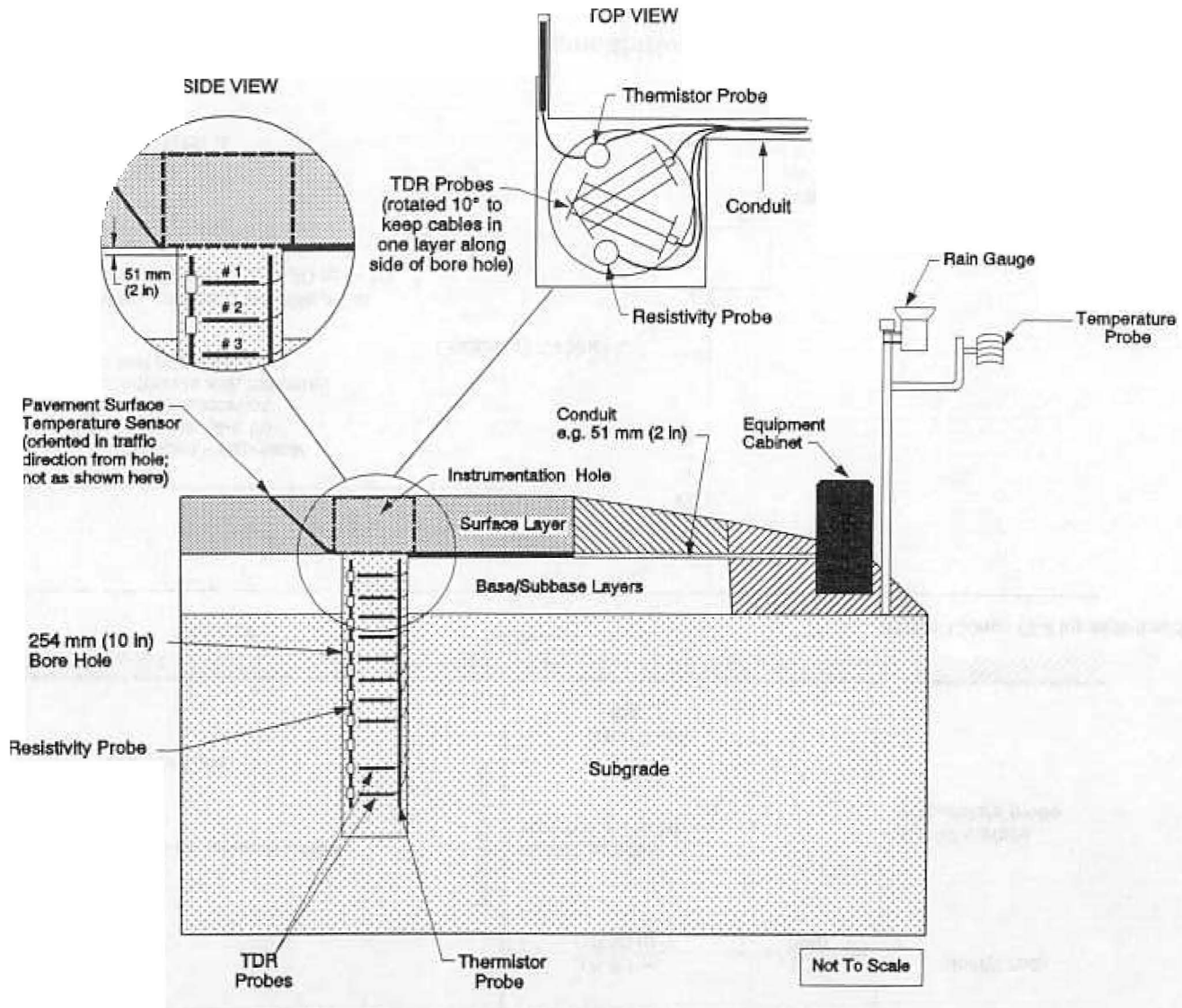

Figure II-13 - Illustration of Instrumentation Installation

**Table II-1 - Roles and Responsibilities - Core Experiment**

| <b>Element</b>   | <b>Lead Role</b>  | <b>Supporting Role</b>   |
|--|---|--|
| <b>Planning:</b><br>Experimental Design<br>Data Collection Plan<br>Preliminary Site Selection<br>Final Site Selection<br>Monitoring Guidelines   | FHWA-LTPP, TAC<br>FHWA-LTPP, TAC<br>RCOC<br>FHWA-LTPP, TAC<br>FHWA-LTPP, TAC                      | RCOC<br>RCOC<br>HA<br>RCOC, HA<br>RCOC   |
| <b>Basic Instrumentation:</b><br>Selection<br>Installation Guidelines<br>Purchase<br>Installation <sup>1</sup><br>Excavation and Drilling<br>Benchmark (optional)<br>Instrument placement<br>Moisture Measurement<br>Pavement restoration<br>Monitoring <sup>1</sup><br>Maintenance <sup>1</sup> | FHWA-LTPP, TAC<br>FHWA-LTPP, TAC<br>FHWA-LTPP<br><br>HA<br>HA<br>RCOC<br>HA<br>HA<br>RCOC<br>RCOC | ETG, RCOC<br>RCOC<br>TAC, RCOC<br><br>RCOC<br>RCOC<br>FHWA-LTPP, TAC<br>RCOC<br>RCOC<br>HA |
| Traffic Control<br>Deflection Testing <sup>1</sup><br>Longitudinal Profile Measurement <sup>2</sup><br>Rod and Level Surveys <sup>1</sup><br>Distress Surveys <sup>2</sup><br>Training/Guidelines<br>Data Collection   | HA<br>RCOC<br>RCOC<br>RCOC<br>PASCO, RCOC<br>FHWA-LTPP, TAC<br>RCOC                               | <br><br><br>HA<br>RCOC   |

<sup>1</sup> Activities requiring traffic control

<sup>2</sup> Activities requiring traffic control when done manually

TAC - LTPP Technical Assistance Contractor

RCOC - Regional Coordination Office Contractors

HA - Highway Agency

ETG - In Situ Instrumentation Expert Task Group

**Table II-2 - Roles and Responsibilities - Supplemental Studies**

| Element  | Lead Role   | Supporting Role   |
|--|---|---|
| <b>Planning:</b><br>Experimental Design<br>Data Collection Plan<br>Preliminary Site Selection <sup>1</sup><br>Final Site Selection <sup>1</sup><br>Monitoring Guidelines   | FHWA-LTPP, TAC<br>FHWA-LTPP, TAC<br>HA<br>HA<br>FHWA-LTPP, TAC                            | RCOC, ETG<br>RCOC, ETG<br>RCOC<br>RCOC<br>RCOC  |
| <b>Basic Instrumentation:</b><br>Selection<br>Installation Guidelines<br>Purchase<br>Installation <sup>2</sup><br>Excavation and Drilling<br>Benchmark (optional)<br>Instrument placement<br>Moisture Determination<br>Pavement restoration<br>Monitoring <sup>2</sup><br>Maintenance <sup>2</sup> | HA<br>FHWA-LTPP, TAC<br>HA<br>HA<br>HA<br>HA<br>HA<br>HA<br>HA<br>HA                      | FHWA-LTPP, TAC<br>RCOC<br>TAC, RCOC<br>RCOC<br>RCOC<br>RCOC<br>RCOC<br>RCOC<br>RCOC<br>RCOC |
| Traffic Control<br>Deflection Testing <sup>2</sup><br>Longitudinal Profile Measurement <sup>3</sup><br>Rod and Level Surveys <sup>2</sup><br>Distress Surveys <sup>3</sup><br>Training/Guidelines<br>Data Collection   | HA<br>HA<br>HA, RCOC <sup>4</sup><br>HA<br>HA, PASCO <sup>4</sup><br>FHWA-LTPP, TAC<br>HA | RCOC<br>RCOC<br>RCOC  |

<sup>1</sup> Limited to LTPP test sections

<sup>2</sup> Activities requiring traffic control

<sup>3</sup> Activities requiring traffic control when done manually

<sup>4</sup> Performed by LTPP contractors as part of standard monitoring

TAC - LTPP Technical Assistance Contractor

RCOC - Regional Coordination Office Contractors

HA - Highway Agency

ETG - In Situ Instrumentation Expert Task Group

- The participating highway agency is responsible for providing traffic control for both instrumentation installation and data collection. The highway agency is also responsible for sawing of the pavement layers and augering of all instrumentation holes. The highway agency may also choose to purchase, install, operate, and maintain its own instrumentation.
- The RCOC is responsible for instrument installation and data collection. RCOC staff will install instrumentation in the bore hole, set up the weather station, wire the equipment cabinet, and collect instrumentation data. The RCOC is also responsible for pavement performance testing: deflection testing, longitudinal profile measurements, distress surveys, and rod-and-level surveys.
- FHWA-LTPP Division, with support of its Technical Assistance Contractor (TAC; PCS/Law Engineering), is responsible for overall supervision of the program. FHWA and TAC establish the experimental design, data collection plan, and monitoring guidelines for the study. While the RCOC is responsible for preliminary site selection, FHWA with concurrence from TAC and the participating highway agency is responsible for final site approval. Once planning stages of the experiment are complete, implementation and monitoring are the RCOC responsibility. FHWA is also responsible for procuring, or instructing the RCOC to procure, instrumentation and equipment required for installations in the core experiment.

## Pre-Installation Activities

Prior to instrumentation installation, several important planning and preparatory activities must be undertaken for efficient use of available time and resources. These activities are summarized below in the order to be performed. After completion of these activities, all personnel must be ready to proceed with their responsibilities, locations for the instrumentation must be finalized, and all sensors must be ready for installation.

### Creation of an RCOC Installation Team

The RCOC should appoint a seasonal instrumentation team to install, operate, and maintain the equipment. The structure shown in Table II-3 is recommended, but each RCOC will have to develop the team around its available staff.

### Collection of Test Section Information

After an LTPP section has received final approval for inclusion in the SMP, respective RCOC's should collect and organize the following information:

**Table II-3 - RCOC Installation Team**

| <b>Position</b>            | <b>Typical Qualifications</b> | <b>Role</b>   |
|----------------------------|-------------------------------|---|
| Supervisor                 | Senior Engineer               | Overall coordination, upper level agency contacts, coordination with FHWA-LTPP division, TAC                      |
| Team Leader                | Engineer<br>Senior Technician | Coordination of field team, working level agency contacts, detail operations, and data review position            |
| Instrumentation Technician | Engineer<br>Senior Technician | Instrumentation installation, instrument operation, calibration, wiring, trouble-shooting, maintenance, surveying |
| Technician                 | Junior Technician             | Assistance  |
| FWD Operator               | Technician                    | Assistance  |

**Materials sampling and testing data:** thickness and material type for pavement layers; in situ density, moisture content and grain size distribution for unbound base, subbase and subgrade layers; and other pertinent information.

- **Deflection data:** previous deflection measurements and FWDCHECK output files and plots.

Note: deflection measurements must be performed on the test section within 12 months prior to the planned installation. In addition to measurements within the test sections, outer-wheel path measurements should also be made at 1.5 to 3.0 m (5 to 10 ft) intervals between stations 0-40 and 0-10 and stations 5+10 and 5+40 on flexible pavements. Tests on rigid pavements should include mid-slab measurements on the first and last four slabs within the section and two slabs outside the section on each end. These deflection measurements should be processed with the FWDCHECK program to determine how representative the potential instrumentation areas are of the actual test section.

- **Distress data:** previous distress survey data including summary data and distress maps (from PASCO or manual surveys) and other useful information such as rut depths.
- **Profile data:** previous profile survey data; PROFCHECK output files for the referenced data; and other pertinent information.
- **Photographic records:** videotape from site verification; distress photographs; photographs from drilling and sampling; and other photographic/video records of the site, if available.

**Project location information:** agency, county, and district; route name and route number; direction; milepost data; and any other information (e.g., maps) to help locate the section.

Other useful information includes traffic data, estimated ground water and frost/thaw depth, depth to bedrock, and environmental data. This information should be organized into a notebook or file for ready reference.

### Preliminary Site Review

After completing data collection, the RCOC must review resulting information to select the test section end to instrument. For AC pavements, the first or last 61 m (200 ft) within the section are used for response monitoring in the seasonal program; for PCC pavements, the length of section monitored will vary according to panel length. The following criteria have been developed for making this selection:

- The section end most uniform, as determined by deflection, materials, distress and profile data, should be selected for monitoring, unless there are other overriding factors such as uniform wind and sun exposure. In determining the most suitable end, the pavement area adjacent to the instrumentation area must be representative of the test section being monitored. The deflection, structural capacity and subgrade support versus station plots generated by the FWDCHECK program from all deflection measurements should be inspected to select the most uniform and representative section end to monitor.

If neither instrumentation area is representative of the adjacent section end, serious consideration should be given to selecting an alternate section, because measurements obtained from the subsurface sensors may not be representative of the section end being monitored. Alternatively, if both ends are similar, other factors below should be considered.

- The section end with the least amount of distress, especially cracking and rutting, should be selected. This is to avoid, to the extent possible, unrepresentative infiltration of surface water into the pavement structure which may lead to erroneous or misleading moisture readings and other measured parameters.
- For those sections where uniformity and amount of distress present at either end are similar, preference should be given to the down stream section end. This is to minimize any undesirable dynamic loading effects from traffic that may result if instrumentation (seasonal or other) is placed before the monitoring section end.
- To the extent possible, every effort should be made to avoid cut and fill transition areas, including cross-over approaches and culverts, within the seasonal test section. Like the first criterion, this one is intended to provide for a uniform monitoring area.
- The equipment cabinet location is another important consideration in selecting the section end to monitor. To minimize costs and obtain a stronger signal, lead wire lengths were restricted and require the equipment cabinet be no more than 9 m (30 ft) away from the edge of the driving lane. For highway safety consideration, the equipment cabinet and 51 mm (2 in) climate sensor pole are considered breakaway objects.
- Safety is an important consideration in selecting the section end to monitor since pavement sections will be tested 12 to 14 times per year, and many of them consist of two-lane roadways (one-lane in each direction). Accordingly, the ability to set up proper traffic control, maintain good sight distances, and other safety features at the chosen section end must be carefully examined.

Selection of a section end based on criteria other than those noted above must be approved by FHWA-LTPP Division staff. The criteria for end selection must be included in the site installation report.

### Onsite Inspection

Once the section monitoring end has been tentatively selected, the RCOC Supervisor or Team Leader must inspect the site to examine the general condition of the pavement (distress locations), safety and traffic control related issues, and suitable location for the equipment cabinet. In addition, the RCOC's should take advantage of this visit to:

- Identify underground utilities and arrange for any necessary excavation permits.  
  
Select final locations for the instrumentation hole, observation piezometer, and equipment cabinet.  
  
Locate the nearest hardware, plumbing and electrical supply stores, since additional items may be required during the installation.
- Locate the nearest hotel(s) and restaurant(s), since most participants will need to stay in the general vicinity for at least one night, and possibly two, during instrumentation installation.
- After selecting the section end to instrument, determine target sensor depths from the pavement surface based on layer information from previous drilling and sampling following guidelines in this document. A table of sensor depths for use during installation should be created.

This onsite inspection should be scheduled 4 to 6 weeks or more prior to instrumentation installation to allow completion of remaining pre-installation activities. In many instances, site inspections and preliminary planning meetings can be combined.

### Preliminary Planning Meeting with Highway Agency

Prior to site installation, the RCOC must coordinate activities with the participating highway agency using a preliminary planning meeting to discuss and plan all required activities. Discussion topics should include program review, site location and instrumentation layout, installation procedures, materials and equipment, schedule, installation team, agency contacts, and responsibilities. A sample agenda is shown in table II-4. Assignments should be distributed at this meeting, and any special onsite safety criteria should be reviewed. The preliminary planning meeting should be scheduled between 2 to 4 weeks prior to the installation date. It is important that highway agency personnel involved in the work attend

this meeting. Meeting attendants could include the SHRP agency coordinator, the LTPP agency contact, local highway district personnel, FHWA division personnel, and FHWA-LTPP Division personnel.

It is further recommended that prior to the meeting, the RCOC send a letter to appropriate highway agency officials discussing details of the SMP. The letter should outline roles and responsibilities of each participating agency and should include details on materials and equipment to be provided by each agency. A preliminary meeting agenda should be included.

In some circumstances, a second planning meeting may be necessary with local highway agency officials if the first meeting was held with central office personnel.

After the planning meeting(s), the RCOC should send a letter to all participants discussing issues raised at the meeting. It should summarize all decisions reached regarding materials, equipment, scheduling, responsible parties, contact names, and installation procedures. The RCOC should maintain telephone contact with each participating agency to check progress of material and equipment acquisition or scheduling.

#### Equipment, Supplies and Materials

As noted earlier, the participating highway agency has primary responsibility for excavation and drilling of the instrumentation hole, restoration of the pavement following instrumentation installation, and traffic control; the primary responsibility of the RCOC is instrument installation; and, the primary responsibility of FHWA-LTPP Division is provision of instrumentation.

Tables II-5 through II-8 summarize materials and equipment needed for instrumentation installation and identify the participating agency responsible for providing them. Tables II-5 and II-6 list general material and equipment requirements, while tables II-7 and II-8 are specific to TDR probes, thermistor probe, electrical resistivity probe, and observation piezometer. While every effort was made to make these lists as comprehensive as possible, unusual site conditions may require items not shown, which is why it is important to locate the nearest hardware, plumbing and electrical supply stores.

The RCOC's must ensure materials and equipment which they are responsible for are ready, calibrated and in working order at least 1 week prior to installation. Calibration and verification of sensors and equipment is discussed later in the next section.

#### Equipment Assembly

The following equipment must be assembled prior to installation:

**Table II-4 - Sample Agenda for Preliminary Planning Meeting**

**Seasonal Monitoring Instrumentation  
Preliminary Planning Meeting**

*Discussion Topics*

**Introduction**

- Objectives of seasonal monitoring program
- Overview of activities

**Site**

- Section location
- Instrumentation Layout
- Planned Rehabilitation and Maintenance
- Underground Utilities

**Installation Procedures, Materials and Equipment**

- Instrumentation: sensors and procedures
  - TDR Probes
  - Electrical Resistivity Probe
  - Thermistor Probe
  - Air Temperature and Rain Gauge
  - Equipment Cabinet and Onsite Instrumentation
  - Observation Piezometer
- Materials and equipment
  - Drill Rig
  - Pavement Saw
  - Tools
  - Pavement Repair Materials
  - Piezometer Materials
    - Sand
    - Bentonite
    - Access Cover
  - Others

**Schedule**

- Pre-installation meeting
- Traffic Control
- Installation Schedule

**Installation Team and Responsibilities**

- Participating highway agency staff
  - Drill Crew
  - Traffic Control
  - Project Contacts
- RCOC staff
- FHWA staff
- Others

**Table II-5 - List of Materials Required for Instrumentation Installation**

| Item  | Provided by |
|---|-------------|
| Observation piezometer cover assembly   | HA          |
| PCC for monitoring well assembly  | HA          |
| Bentonite and water   | HA          |
| Filter sand for backfilling observation well  | HA          |
| Observation piezometer hardware   | RCOC        |
| Pea gravel (#4 mat cover stone, for base of equipment cabinet)  | RCOC/HA     |
| Anchor bolts, anchors and channel iron assembly for lifting slab or core from pavement                    | RCOC        |
| Sealant and/or other materials for repairing surface temperature probe groove (Dow Corning 888-SL or 890) | RCOC        |
| Bonding agent and/or other materials for repairing pavement core hole (PC-7 Epoxy or equivalent)          | RCOC/HA     |
| Pole assembly for temperature probe/rain gauge  | RCOC        |
| Sackcrete for temperature/rain gauge support  | RCOC/HA     |
| Equipment cabinet   | FHWA-LTPP   |
| Flexible electrical conduit [51 mm (2 in), 9.7 m (32 ft) long]  | RCOC        |
| Silicone sealant or duct seal for conduit   | RCOC        |
| SHRP labels for cabinet   | FHWA-LTPP   |
| Pavement marking paint  | RCOC        |
| Bore hole instrumentation depth log   | RCOC        |
| Big sponge  | RCOC        |
| Tape (duct, electrical wire labeling tape, electrical tape)   | RCOC        |
| Tie wraps (various sizes)   | RCOC        |
| Moisture sample containers (plastic jars or Ziploc plastic bags)  | RCOC        |
| Marking pens  | RCOC        |
| Clip boards   | RCOC        |
| Fifteen 19-liter (5-gallon) plastic buckets with lids (more if large auger is used)                       | RCOC        |
| Ground Rod with Coupling (meeting local code)   | RCOC        |
| Internal snap rings and silicon sealer/adhesive (PCC sites only)  | RCOC        |
| Cold or hot mix patching material   | HA          |

HA - Highway Agency; RCOC - Regional Coordination Office Contractor

**Table II-6 - List of Equipment Required for Instrumentation Installation**

| Item   | Provided by |
|--|-------------|
| Drill rig for coring and augering [305-mm (12-in) diameter core barrel, minimum 254-mm (10-in) solid stem auger desired]   | HA          |
| Concrete pavement saw  | HA          |
| Large down hole compactor [102 mm (4 in) diameter by 2.4 m (8 ft) long wood post] with holes for handle, depth measurements  | RCOC        |
| Small down hole compactor [13-mm (0.5-in) metal pipe with floor flange 2.4 m (8 ft) long]  | RCOC        |
| Field moisture measurement equipment (scale, tins, sample containers, camp stove plus fuel, and calculator)  | RCOC        |
| Down hole measurement rod, tape measure, florescent light and manipulation tool [13-mm (0.5-in) angle iron or split PVC (51 mm (2 in) diameter) 2.1 m (7 ft) long] | RCOC        |
| Electrical extension cords and wiring tools (soldering gun, wire strippers and cutters, heat shrink wrap, and heat gun for shrink wrap)                            | RCOC        |
| Mobile workbench (Workmate), hack saw and level [0.6 m (2 ft)]   | RCOC        |
| Wet/dry vacuum, brooms (corn broom/push), wire brush (long handle) and dust pan  | RCOC        |
| Shovels (flat/pointed nose), rake hand trowel and scoop  | RCOC        |
| Video camera and 4 tapes, camera tripod (optional)   | RCOC        |
| One still 35-mm camera plus 2 rolls 100 ISO film   | RCOC        |
| Heavy duty pry bar - tamper  | RCOC        |
| Metal files (various types)  | RCOC        |
| Sledge hammer, hammer drill and bits and pick axe  | RCOC        |
| Pipe wrench (large)  | RCOC        |
| Step ladder, 1.8 to 2.4 m (6 to 8 ft)  | RCOC        |
| Utility knife  | RCOC        |
| Internal snap rings and snap ring pliers   | RCOC        |
| Plummer's fish line  | RCOC        |
| Post driver  | RCOC        |
| First aid kit  | RCOC        |
| Hard hats, vests, and necessary safety equipment   | RCOC        |
| Gloves, kneepads and utility tent (optional)   | RCOC        |

**Table II-7 - Instrumentation and Measurement Equipment**

| Item  | Provided by        |
|---|--------------------|
| FHWA TDR probes and cables (10 probes per site) <sup>1</sup>                      | FHWA-LTPP          |
| MRC thermistor probe (one per site) <sup>1</sup>                                  | FHWA-LTPP          |
| CRREL resistivity probe (one per site) <sup>1</sup>                               | FHWA-LTPP          |
| Air temperature probe with shield (one per site) <sup>1</sup>                     | FHWA-LTPP          |
| Tipping bucket rain gauge (one per site) <sup>1</sup>                             | FHWA-LTPP          |
| Tektronix 1502B cable tester (one per region)                                     | FHWA-LTPP          |
| SMD 1502 communicator interface and PS1502B power control module (one per region) | FHWA-LTPP/<br>RCOC |
| SDMX50 TDR Multiplexers (2 per region)  | FHWA-LTPP          |
| CRREL Resistivity Multiplexer (1 per region)                                      | FHWA-LTPP          |
| MRC readout unit (RD100 or RD200)   | FHWA-LTPP          |
| AC Power supply, Simpson 420D model - function generator                          | FHWA-LTPP          |
| Electrical multimeters (2 per region)   | FHWA-LTPP          |
| CR10 dataloggers (1 permanent, 1 portable) <sup>1</sup>                           | FHWA-LTPP          |
| Batteries (YUASA gel cell) <sup>1</sup>   | RCOC               |
| Notebook computer   | FHWA-LTPP          |
| Serial computer cable   | RCOC               |

<sup>1</sup> It is recommended that spare instrumentation be carried to each site, if possible.

**Table II-8 - Materials for Observation Piezometer/Benchmark**

| Item  | Provided by |
|---|-------------|
| One slotted galvanized steel pipe [25 mm (1.0 in) by 2.1 m (7 ft)] <sup>1</sup>                     | RCOC        |
| One galvanized steel pipe [25 mm (1.0 in) by 2.1 m (7 ft)] <sup>1</sup>                             | RCOC        |
| One 25 mm (1.0 in) pipe couple  | RCOC        |
| One pipe floor flange modified with large base  | RCOC        |
| One galvanized steel pipe [32 to 38 mm by 1.5 m (1.25 to 1.5 in by 5 ft)] <sup>1</sup>              | RCOC        |
| Two metal caps for 25.4-mm (1-in) or 38-mm (1.5-in) steel pipe [bored to clear 25 mm (1.0 in) pipe] | RCOC        |
| Two grease zerk fittings  | RCOC        |
| Grease gun with waterproof grease (fits zerk)   | RCOC        |
| Filter sand for backfilling observation piezometer  | HA          |
| Bentonite for observation piezometer  | HA          |
| Concrete to seat surface access covers  | HA          |
| Surface access cover  | HA          |
| Steel Tape measure [6 m (20 ft)]  | RCOC        |
| Two pipe wrenches   | RCOC        |
| Extra couplers  | RCOC        |
| Filter fabric   | RCOC        |
| Plastic ties  | RCOC        |
| Weighted 13-mm (0.5-in) fishing float with line   | RCOC        |
| Pipe end cover [25 mm (1.0 in)]   | RCOC        |

<sup>1</sup> May have to modify for deep frost; refer to Instrumentation Overview section in this chapter

Note: list of materials may be modified if highway agency installs permanent benchmark

- Mobile recording unit - The mobile recording unit consists of a Campbell Scientific CR10 datalogger, two TDR multiplexer boards (SDMX50), CRREL electrical resistance measurement multiplexer, and PS12A power supply mounted inside a rugged carrying case. The recommended layout of the mobile recording unit in the carrying case is shown in figure II-10. The wiring diagram is shown in figures II-8 and II-9.
- Onsite datalogger panel - The onsite datalogger panel consists of a terminal wiring strip, CR10 datalogger, Crydom D1D07 SPST solid state relay, and battery power pack mounted on the equipment cabinet panel. The component layout and wiring diagram for this panel are shown in figure II-11.
- Air temperature and rain gauge support assembly - This consists of drilling 6- to 16-mm (0.25- to 0.625-in) diameter holes at the various wire insertion and exit locations in the support pipe. The exit hole diameter should correspond to the diameter of the electrical conduit coupler used.

### Instrumentation Calibration & Function Checks

A week prior to instrumentation installation, all materials and equipment must be ready. This includes calibration or check-out of TDR, thermistor, electrical resistivity and air temperature probes, rain gauge, and associated equipment by the RCOC's.

### *TDR Probes*

When TDR probes are received by the RCOC, each probe should be labeled with a serial number for a specific site according to depth, with "1" used for the probe closest to the surface and "10" for the deepest probe. The probe cables should be labeled at a point near the sensor and every 0.6 m (2 ft) apart starting at the BNC connector in case cables are accidentally cut. Numbered wire labeling tape works well for this purpose.

Serial number convention for TDR probes consist of the following five digit code:

S S A # #

|                         |   |
|-------------------------|---|
| where <u>S</u> <u>S</u> | Two digit LTPP agency code in which the probe will be placed.   |
| <u>A</u>                | Multiple site designator <u>within</u> the same agency; "A" for the first site to be instrumented, then letters assigned to the multiple sites sequentially; e.g., "B", "C", etc. |
| # #                     | Probe depth designation; 01 is assigned to the probe closest to the surface and 10 to the deepest probe.  |

For example, probe 32A10 would be the deepest TDR probe in the first seasonal test site instrumented in Nevada.

The bond between the BNC bulkhead jack and circuit board on the TDR probe should be inspected. The bond should be reinforced with a plastic tie wrap inserted through holes in the circuit board on each side of the BNC bulkhead jack. The seal on the BNC bulkhead jack should be inspected for cracks or defects. Water in this connector causes a secondary "blip" at the beginning of the trace, and this condition can be detected when the probe is immersed in water. To correct this condition, the connector should be dried and a silicone caulk applied to seal this groove. After the new seal has cured, the probe should be rechecked in water.

TDR probes are checked in air, distilled water, and shorted. Measurements are performed with the cable tester in manual measurement mode using the strip chart recorder and the following settings:

|              |  |
|--------------|--|
| $V_p$        | 0.99   |
| DIST/DIV     | 0.25 m/div   |
| VERT SCALE   | adjust to largest setting that keeps the entire trace for the probe on the screen; approximately 175 mp/div for air and 75 mp/div for water. |
| Noise Filter | 1 average  |

The sequence of checks is as follows:

- The first check is performed with the TDR shorted using a metal ruler positioned directly adjacent to the circuit board to short the center electrode to one of the outer electrodes. This will cause a sharp single peak at the beginning of the probe trace. Align the vertical cursor on the cable tester display with this peak within the left 1/3 of the screen. Aligning this peak with a vertical grid line simplifies determining the apparent length of the probe. The distance to the peak will typically be shown as approximately 15.9 m (52 ft) on the cable tester display with the cursor in this position. (This is different than the physical length of the wire since the signal propagation velocity,  $V_p$ , is different from the true propagation velocity of the lead wire.) Print this trace. Write the date on the date line, probe serial number on the cable line, and "shorted at start" on the notes line of the trace printout. Leave the cursor in this position for the measurement in air.
- Next, remove the short and print the trace with the probe held in air by the lead wire and positioned a minimum of 152 mm (6 in) away from any other object. On the output trace, record the date, probe serial number, and on the notes line record "in air."

- Finally, holding the TDR probe by the lead cable, immerse the probe in distilled water contained in a 19-L (5-gal) plastic bucket. The probe should be held parallel with the bottom of the bucket and positioned in the center of the bucket with at least 152 mm (6 in) of water below and above the probe rods. Measure the water temperature to the nearest 0.1 °C. Position the cursor at the center of the first peak on the trace and print. On the output trace, record the date, probe serial number, and on the notes line record the water temperature and "in water."

Using the equations and procedures presented earlier in this document (see page II-2), the dielectric constants in air and water should be computed. The dielectric constants should be within the following ranges:

- Air - 0.75 to 2.0.  
Water - 76 to 84.

The three probe traces for each sensor should be copied onto Data Sheet SMP-C01, along with the associated dielectric constant computations. This information should also be included in the site installation report. If the computed dielectric constants in air and water fall outside of the noted ranges, contact the FHWA-LTPP division for further guidance.

### *Thermistor Probe*

Each thermistor probe is assigned a serial reference number using the following four digit code:

S S A T

where S S Two digit LTPP agency code in which the probe will be placed.  
A Multiple site designator within the same agency.  
T Use the letter T for the MRC thermistor probe.

Check-out procedures for the probe verify accuracy of the individual thermistors and include measurement of thermistor locations. To perform the accuracy check, the thermistor probe is hooked to a functional CR10 onsite datalogger. The entire probe is immersed in an ice-bath, and measured temperatures are compared to the expected value (0 °C or 32 °F). The same procedure is repeated at higher temperatures — e.g., in direct sunlight. Thermistors that do not match the known temperatures within the accuracy specified by the manufacturer ( $\pm 1$  °C) will be considered defective and must be replaced.

In addition to the accuracy check, the distance from the top of the probe to each individual thermistor is measured and recorded on Data Sheet SMP-C02. The red spot on the tip of each thermistor should be used as the measurement reference.

|  |  |
|--|--|
| LTPP Seasonal Monitoring Program<br>Data Sheet SMP-C01 (Page 1)<br>TDR Probe Check | Agency Code <span style="float: right;">[ ]</span><br>LTPP Section ID <span style="float: right;">[ ]</span> |
|--|--|

Place TDR trace "Shorted at Start" here

| TDR Trace          | Apparent Length, (m) | Dielectric Constant |
|--------------------|----------------------|---------------------|
| "Shorted at Start" | _ . _ _              | _ . _ _             |

Place TDR trace "In Air" here

| TDR Trace | Apparent Length, (m) | Dielectric Constant <sup>d</sup> |
|-----------|----------------------|----------------------------------|
| "In Air"  | _ . _ _              | _ . _ _                          |

Data Sheet SMP-C01: TDR Probe Check

|  |  |
|--|--|
| LTPP Seasonal Monitoring Program<br>Data Sheet SMP-C01 (Page 2)<br>TDR Probe Check | Agency Code [ ]<br>LTPP Section ID [ ] |
|--|--|

Place TDR trace "In Water" here

| TDR Trace  | Apparent Length, (m) | Dielectric Constant <sup>2</sup> |
|------------|----------------------|----------------------------------|
| "In Water" | _ . _ _              | _ _ . _ _                        |

<sup>1</sup> If dielectric constant not between 0.75 and 2.0, contact FHWA LTPP Division

<sup>2</sup> If dielectric constant not between 76 and 84, contact FHWA LTPP Division

Note: Dielectric constant is determined as follows:

$$\epsilon = \left[ \frac{(L_a)}{(L)(V_p)} \right]^2 = \left[ \frac{(D_2 - D_1)}{(L)(V_p)} \right]^2$$

where  $\epsilon$  = dielectric constant;  $L_a$  = apparent length of probe, m; L = actual length of probe units (= 0.203 m (8 in) for FHWA probes);  $V_p$  = phase velocity setting (= 0.99).

TDR Probe Assigned Serial Number: \_ \_ \_ \_ \_ Measured Length of Coax Cable: \_ \_ . \_ m

Comments: \_\_\_\_\_

Prepared by: \_\_\_\_\_ Employer: \_\_\_\_\_

Date (dd/mm/yy): \_ \_ / \_ \_ / \_ \_

|  |  |
|--|--|
| LTPP Seasonal Monitoring Program<br>Data Sheet SMP-C02<br>Thermistor Probe Check | Agency Code <span style="float: right;">[ ]</span><br>LTPP Section ID <span style="float: right;">[ ]</span> |
|--|--|

Thermistor Probe Assigned Serial Number : [ ] [ ] [ ] T

Air Temperature Probe Assigned Serial Number: [ ] [ ] [ ] A T

| Thermistor Number | Distance from Top (m) | Temperature (°C) – Calibration in: |                       | Comments |
|-------------------|-----------------------|------------------------------------|-----------------------|----------|
|                   |                       | Ice-Bath;<br>T = _____ °C          | Other<br>T = _____ °C |          |
| 1                 | _____                 | _____                              | _____                 |          |
| 2                 | _____                 | _____                              | _____                 |          |
| 3                 | _____                 | _____                              | _____                 |          |
| 4                 | _____                 | _____                              | _____                 |          |
| 5                 | _____                 | _____                              | _____                 |          |
| 6                 | _____                 | _____                              | _____                 |          |
| 7                 | _____                 | _____                              | _____                 |          |
| 8                 | _____                 | _____                              | _____                 |          |
| 9                 | _____                 | _____                              | _____                 |          |
| 10                | _____                 | _____                              | _____                 |          |
| 11                | _____                 | _____                              | _____                 |          |
| 12                | _____                 | _____                              | _____                 |          |
| 13                | _____                 | _____                              | _____                 |          |
| 14                | _____                 | _____                              | _____                 |          |
| 15                | _____                 | _____                              | _____                 |          |
| 16                | _____                 | _____                              | _____                 |          |
| 17                | _____                 | _____                              | _____                 |          |
| 18                | _____                 | _____                              | _____                 |          |
| End               | _____                 | n/a                                | n/a                   |          |
| Air Probe         | n/a                   | _____                              | _____                 |          |

Comments: \_\_\_\_\_  
 \_\_\_\_\_  
 \_\_\_\_\_

Prepared by: \_\_\_\_\_ Employer: \_\_\_\_\_

Date (dd/mm/yy):        /        /

### *Electrical Resistivity Probe*

Electrical resistivity probes are assigned a serial reference number consisting of S S A R, where S S and A are the same as for the other probes, and R indicates electrical resistivity probe.

Check-out procedures (there is no calibration procedure per say) consist of continuity checks for each wire lead and measurement of electrode locations from the top of the probe. First check for cold solder joints; scrap off any excess resin from solder. To perform the continuity/connection check, set the multimeter to either the resistance setting or continuity check setting. Verify that the test leads on the multimeter are in the correct positions. Touch one test lead to position 1 in the connector and the other test lead to the bottom electrode on the probe (the top of the probe is the end with the cable connection). Continuity should be indicated on the multimeter. Then touch all other electrodes to verify that they are not shorted to this electrode wire. Repeat this process for all pins in the connector. Place a check mark in the continuity column on Data Sheet SMP-C03 to indicate continuity between the electrode and pin in the connector was verified. Use of the manual switch box will simplify this procedure.

If an electrode lacks continuity with the pin in the connector, first check all connections. Touch the two test leads on the multimeter to ensure that it is working properly. Note that pin 37 in the connector is not used. All faults in continuity or wiring must be corrected prior to installation of a probe.

Each electrode consists of approximately 2 1/2 wraps of wire. Make sure the electrodes are wrapped tight to the PVC and no gap exists between adjacent wraps. The distance from the top of the probe to each electrode is measured at two points (see figure II-4) and recorded on Data Sheet SMP-C03. The two measurement lines should be located at transition points between the 3 and 2 wire wrap portions of the electrodes. Measure and record the distance from the top of the probe to each electrode to the nearest 0.5 mm (0.02 in).

After all measurements have been made, compute and record the average of the two measurements in the appropriate column on Data Sheet SMP-C03. Then using the average distance from the top of the probe, compute and record the spacing between adjacent electrodes on Data Sheet SMP-C03.

Operation of the function generator and multimeters are checked by measuring current flow through and voltage drop across known resistors. The function generator and multimeters are connected as shown in figure II-5A for contact resistance measurement. The multimeters are set to alternating current (AC). The resistor is positioned between positions  $V_1-I_1$  and  $V_2-I_2$  and measurements are recorded on Data Sheet SMP-C04 using the following procedure:

|   |  |
|---|--|
| LTPP Seasonal Monitoring Program<br>Data Sheet SMP-C03<br>Resistivity Probe Check | Agency Code <span style="float: right;">[    ]</span><br>LTPP Section ID <span style="float: right;">[    ]</span> |
|---|--|

Electrical Resistivity Serial Number: R

| DB37<br>Connector<br>Pin Number | Electrode<br>Number | Distance from Top (m) |         |         | Conti-<br>nuity ✓ | Spacing (m) | Comments |
|---------------------------------|---------------------|-----------------------|---------|---------|-------------------|-------------|----------|
|                                 |                     | Line 1                | Line 2  | Avg     |                   |             |          |
| 36                              | 1                   | — . ———               | — . ——— | — . ——— |                   | — . ———     |          |
| 35                              | 2                   | — . ———               | — . ——— | — . ——— |                   | — . ———     |          |
| 34                              | 3                   | — . ———               | — . ——— | — . ——— |                   | — . ———     |          |
| 33                              | 4                   | — . ———               | — . ——— | — . ——— |                   | — . ———     |          |
| 32                              | 5                   | — . ———               | — . ——— | — . ——— |                   | — . ———     |          |
| 31                              | 6                   | — . ———               | — . ——— | — . ——— |                   | — . ———     |          |
| 30                              | 7                   | — . ———               | — . ——— | — . ——— |                   | — . ———     |          |
| 29                              | 8                   | — . ———               | — . ——— | — . ——— |                   | — . ———     |          |
| 28                              | 9                   | — . ———               | — . ——— | — . ——— |                   | — . ———     |          |
| 27                              | 10                  | — . ———               | — . ——— | — . ——— |                   | — . ———     |          |
| 26                              | 11                  | — . ———               | — . ——— | — . ——— |                   | — . ———     |          |
| 25                              | 12                  | — . ———               | — . ——— | — . ——— |                   | — . ———     |          |
| 24                              | 13                  | — . ———               | — . ——— | — . ——— |                   | — . ———     |          |
| 23                              | 14                  | — . ———               | — . ——— | — . ——— |                   | — . ———     |          |
| 22                              | 15                  | — . ———               | — . ——— | — . ——— |                   | — . ———     |          |
| 21                              | 16                  | — . ———               | — . ——— | — . ——— |                   | — . ———     |          |
| 20                              | 17                  | — . ———               | — . ——— | — . ——— |                   | — . ———     |          |
| 19                              | 18                  | — . ———               | — . ——— | — . ——— |                   | — . ———     |          |
| 18                              | 19                  | — . ———               | — . ——— | — . ——— |                   | — . ———     |          |
| 17                              | 20                  | — . ———               | — . ——— | — . ——— |                   | — . ———     |          |
| 16                              | 21                  | — . ———               | — . ——— | — . ——— |                   | — . ———     |          |
| 15                              | 22                  | — . ———               | — . ——— | — . ——— |                   | — . ———     |          |
| 14                              | 23                  | — . ———               | — . ——— | — . ——— |                   | — . ———     |          |
| 13                              | 24                  | — . ———               | — . ——— | — . ——— |                   | — . ———     |          |
| 12                              | 25                  | — . ———               | — . ——— | — . ——— |                   | — . ———     |          |
| 11                              | 26                  | — . ———               | — . ——— | — . ——— |                   | — . ———     |          |
| 10                              | 27                  | — . ———               | — . ——— | — . ——— |                   | — . ———     |          |
| 9                               | 28                  | — . ———               | — . ——— | — . ——— |                   | — . ———     |          |
| 8                               | 29                  | — . ———               | — . ——— | — . ——— |                   | — . ———     |          |
| 7                               | 30                  | — . ———               | — . ——— | — . ——— |                   | — . ———     |          |
| 6                               | 31                  | — . ———               | — . ——— | — . ——— |                   | — . ———     |          |
| 5                               | 32                  | — . ———               | — . ——— | — . ——— |                   | — . ———     |          |
| 4                               | 33                  | — . ———               | — . ——— | — . ——— |                   | — . ———     |          |
| 3                               | 34                  | — . ———               | — . ——— | — . ——— |                   | — . ———     |          |
| 2                               | 35                  | — . ———               | — . ——— | — . ——— |                   | — . ———     |          |
| 1                               | 36                  | — . ———               | — . ——— | — . ——— |                   | — . ———     |          |
|                                 | Bottom              | — . ———               | — . ——— | — . ——— | n/a               | n/a         |          |

Comments: \_\_\_\_\_

Prepared by: \_\_\_\_\_

Employer: \_\_\_\_\_

Date (dd/mm/yy): \_\_\_ / \_\_\_ / \_\_\_

**Data Sheet SMP-C03: Electrical Resistivity Probe Check**

|   |  |
|---|--|
| <b>LTPP Seasonal Monitoring Program</b><br><b>Data Sheet SMP-C04</b><br>Function Generator, Multimeter, and Switch Box Checks | Agency Code <span style="float: right;">[    ]</span><br>LTPP Section ID <span style="float: right;">[    ]</span> |
|---|--|

| Test Position  | Switch Settings   |                   | Voltage (ACV) |                 |   |      |   |   |
|----------------|-------------------|-------------------|---------------|-----------------|---|------|---|---|
|                | I, V <sub>1</sub> | I, V <sub>2</sub> | Range Setting | Reading (Volts) |   |      |   |   |
| 36             | 36                | 37                |               | E               | E |      |   | E |
| 37             | 37                | 38                |               | E               |   |      |   |   |
| 38             | 38                | 39                |               | E               |   |      |   |   |
| 3 <sup>~</sup> | 39                | 00                |               | E               |   |      |   |   |
|                |                   |                   |               |                 |   |      |   |   |
| 36             | 36                | 37                |               | E               | E | R1 = | E | E |
| 37             | 37                | 38                |               | E               |   |      |   |   |
| 38             | 38                | 39                |               | E               |   |      |   |   |
| 3 <sup>~</sup> |                   | 00                |               | E               |   |      |   |   |
|                |                   |                   |               |                 |   |      |   |   |
|                |                   | 37                |               | E               | E | R1 = | E | E |
| 37             |                   | 38                |               | E               | E | R2 = | E | E |
| 38             |                   | 39                |               | E               |   |      |   |   |
|                |                   | 00                |               | E               |   |      |   |   |

Comments: \_\_\_\_\_

\_\_\_\_\_  
 \_\_\_\_\_ Employer: \_\_\_\_\_

Date (dd/mm/yy): \_\_\_\_ / \_\_\_\_ / \_\_\_\_

**Data Sheet SMP-C04: Function Generator, Multimeter, and Switch Box Checks**

Seasonal Monitoring Program

2.1/April 1994

1. Connect function generator and multimeters to resistor number 1
2. Record AC voltage and AC amperage as measurement 1 for resistor number 1
3. Connect function generator to the next resistor and record as measurement number 2.
4. Continue Step 3 for other resistors (up to four resistors).
5. Repeat measurement sequence on all resistors a second and third time and record corresponding measurements on Form SMP-C04.
6. Convert readings to absolute units of voltage and amperage, showing all decimal places.
7. Compute electrical resistance of each resistor by dividing voltage by current.

The calculated electrical resistance should be within 2 percent of the actual resistor value as measured using a very accurate multimeter. If the calculated electrical resistances do not match the actual values, then check all connections, wiring, multimeter settings, and position of test leads in the multimeter. Also try the resistance measurement function on each multimeter to check proper meter operation.

#### *Air Temperature Probe and Rain Gauge*

The air temperature probe is assigned a serial number using the convention S S A A T. The S S A designation is the same as the other probes and A T in the last two digits indicates this is an air temperature probe. The tipping bucket rain gauge five digit serial number stamped on the identification label is used as the reference serial number.

Both the air temperature probe and tipping-bucket rain gauge are connected to the onsite CR10 datalogger for check-out procedures. The temperature probe will be checked-out at the same time and using the same procedures as the thermistor probe.

To calibrate the rain gauge, both initially and later in the field, obtain a metal can or plastic container and form a small hole in the bottom that lets 0.473 L (16 oz) of water exit the container in at least 45 min. Fill the container with water, initialize the onsite CR10 program, and let the water spill directly into the rain gauge. The CR10 datalogger program saves the number of tips on hourly intervals; if this test requires more than 1 h to perform, then tips occurring in the second hour will not be recorded until the end of that hour. If accurate, the datalogger will record 100 tips  $\pm 3$  tips. Otherwise, adjust the two screws at the bottom of the rain gauge adjacent to the large center drain hole; a half-turn of both screws in the clockwise direction causes a 2- to 3-percent increase in tips and vice versa.

Measurements, computations, and other data obtained in the calibration or checks of the air temperature probe and rain gauge are recorded on Data Sheets SMP-C02 and SMP-C05, respectively. Details on operation of the electronic systems for the seasonal sensors are given later in this document under operational guidelines.

### Pre-Installation Meeting with Highway Agency

A pre-installation meeting with the participating highway agency should be held within three days of the field installation. Attendees should include highway agency's supervisor(s) and onsite leader, RCOC installation team leader, and FHWA-LTPP Division personnel as appropriate. At this meeting, all plans including scheduling, installation procedures, materials, and equipment should be reviewed. A firm schedule for traffic control should be established and any special onsite safety concerns reviewed.

### Installation Activities

Instrumentation installation is normally completed in two 8-h days. Instrumentation should be placed during the first day and completion of wiring and initial readings and measurements made the second day; however, an effort should be made to complete the wiring on the first day and run the ONSITE program overnight. Traffic control should tentatively be arranged for a third day if needed.

### First Day Activities

Table II-9 shows an example schedule of activities during the first day of installation. Activities include set-up of traffic control, site layout and marking, observation piezometer installation, instrumentation hole preparation and sensor installation, installation of the air temperature probe and rain gauge, cabinet and conduit installation, and site clean-up. Certain activities can be completed concurrently, thus allowing for efficient and timely completion of tasks; see table II-9. Prior to leaving the site the first day, the installation team leader must record the serial reference numbers for the instruments installed and names of participants on Data Sheet SMP-I01 and record all sensor locations on Data Sheet SMP-I02.

All participants should be on site by 8:00 a.m., so that traffic control can be in place by 8:30 a.m. After traffic control has been established, the FWD should begin buffer warm-up. While this is taking place, the instrumentation hole location and FWD seasonal test points should be established. One cycle of FWD should be performed following the seasonal testing protocol, except the instrumentation hole location is included as a test point with lane specification of F9 or J9 for flexible and rigid pavements, respectively. These deflection measurements are performed prior to coring or sawing the instrumentation hole.

|  |                     |
|--|---------------------|
| LTPP Seasonal Monitoring Program<br>Data Sheet SMP-C05<br>Rain Gauge Calibration | Agency Code [ ]     |
|  | LTPP Section ID [ ] |

**General Information:**

Manufacturer: \_\_\_\_\_

Model Number: \_\_\_\_\_

Serial Number: \_\_\_\_\_

**Note:** The screen should be tacked inside the funnel using silicon at three to four points to prevent loss from wind.

| Rain Gauge Calibration Data |                          |                        |                |                   |   |
|-----------------------------|--------------------------|------------------------|----------------|-------------------|---|
| Trial                       | Start Time<br>(Military) | End Time<br>(Military) | Volume<br>(ml) | Number of<br>Tips | Adjustment <sup>1</sup><br>No. of Turns |
| 1                           | _____                    | _____                  | _____.         | _____.            | __ . __                                 |
| 2                           | _____                    | _____                  | _____.         | _____.            | __ . __                                 |
| 3                           | _____                    | _____                  | _____.         | _____.            | __ . __                                 |

Adjust gauge to obtain 100 tips  $\pm$  3 for 473 ml of water.

Comments: \_\_\_\_\_  
 \_\_\_\_\_  
 \_\_\_\_\_  
 \_\_\_\_\_  
 \_\_\_\_\_

Prepared by: \_\_\_\_\_ Employer: \_\_\_\_\_

Date (dd/mm/yy):        / \_\_ \_\_ /

**Table II-9 - Schedule of Activities - Day 1**

| Activity                                    | Time |   |    |    |    |   |   |   |   |   |
|---|------|---|----|----|----|---|---|---|---|---|
|   | 8    | 9 | 10 | 11 | 12 | 1 | 2 | 3 | 4 |   |
| <b>Traffic control</b>                      | █    | █ | █  | █  | █  | █ | █ | █ | █ | █ |
| <b>Observation piezometer</b>               |      |   |    |    |    |   |   |   |   |   |
| Drilling                                    | █    |   |    |    |    |   |   |   |   |   |
| Hardware placement                          |      | █ |    |    |    |   |   |   |   |   |
| Backfill hole                               |      |   | █  |    |    |   |   |   |   |   |
| Surface cover                               |      |   |    | █  |    |   |   |   |   |   |
| <b>FWD testing</b>                          |      |   |    |    |    |   |   |   |   |   |
| Warm up                                     | █    |   |    |    |    |   |   |   |   |   |
| Test (one cycle)                            | █    | █ | █  |    |    |   |   |   |   |   |
| <b>Instrumentation hole</b>                 |      |   |    |    |    |   |   |   |   |   |
| Cut hole and trench                         |      | █ | █  |    |    |   |   |   |   |   |
| Auger                                       |      |   | █  | █  | █  |   |   |   |   |   |
| Place sensors/backfill                      |      |   |    |    | █  | █ | █ | █ |   |   |
| Moisture determinations                     |      |   |    |    | █  | █ | █ | █ |   |   |
| Replace surface cut-out                     |      |   |    |    |    |   |   | █ | █ |   |
| <b>Cabinet and conduit</b>                  |      |   |    |    |    |   |   |   |   |   |
| Location for cabinet                        |      |   |    |    | █  |   |   |   |   |   |
| Dig trench & cabinet hole                   |      |   |    |    | █  | █ |   |   |   |   |
| Run wires in conduit                        |      |   |    |    | █  |   |   | █ |   |   |
| Place cabinet/conduit                       |      |   |    |    |    |   |   | █ | █ | █ |
| Patch trench                                |      |   |    |    |    |   |   |   | █ |   |
| <b>Air temperature probe and rain gauge</b> |      |   |    |    |    |   |   |   |   |   |
| Drill post hole                             |      |   |    |    | █  |   |   |   |   |   |
| Place pole                                  |      |   |    |    | █  |   |   |   |   |   |
| Place probes                                |      |   |    |    |    |   |   | █ |   |   |
| Run wires to cabinet                        |      |   |    |    |    |   |   |   | █ |   |
| <b>Site clean up</b>                        |      |   |    |    |    |   |   |   |   | █ |
| <b>Initiate data collection</b>             |      |   |    |    |    |   |   |   | █ | █ |



|   |                 |     |
|---|-----------------|-----|
| LTPP Seasonal Monitoring Program<br>Data Sheet SMP-102<br>Installed Instrument Location | Agency Code     | [ ] |
|   | LTPP Section ID | [ ] |

**Longitudinal and Transverse Location of Instrumentation:**

| Instrument             | Station (Customary Units) |        | Offset (m) <sup>1</sup> |        |
|------------------------|---------------------------|--------|-------------------------|--------|
|                        | Planned                   | Actual | Planned                 | Actual |
| Instrumentation Hole   | _____                     | _____  | _____                   | _____  |
| Observation Piezometer | _____                     | _____  | _____                   | _____  |
| Equipment Cabinet      | _____                     | _____  | _____                   | _____  |
| Weather Station        | _____                     | _____  | _____                   | _____  |

<sup>1</sup> Transverse distance in meters from pavement edge (see LTPP Manual for FWD Testing) with (+) values toward mid-lane and (-) towards shoulder

**Depth Location of Instrumentation:**

| Instrument        |              | Depth from Pavement Surface to Top of Probe (m) |        | Comments |
|-------------------|--------------|---|--------|----------|
|                   |              | Planned   | Actual |          |
| Thermistor Probe  | Metal Top    | _____   | _____  |          |
|                   | Metal Bottom | _____   | _____  |          |
|                   | PVC Top      | _____   | _____  |          |
| Resistivity Probe |              | _____   | _____  |          |

| TDR Number | Depth from Pavement Surface to Probe (m) |                 | Comments |
|------------|--|-----------------|----------|
|            | Planned Location                         | Actual Location |          |
| 1          | _____                                    | _____           |          |
| 2          | _____                                    | _____           |          |
| 3          | _____                                    | _____           |          |
| 4          | _____                                    | _____           |          |
| 5          | _____                                    | _____           |          |
| 6          | _____                                    | _____           |          |
| 7          | _____                                    | _____           |          |
| 8          | _____                                    | _____           |          |
| 9          | _____                                    | _____           |          |
| 10         | _____                                    | _____           |          |

**ATTACH TOP-VIEW SKETCH OF INSTRUMENTATION HOLE SHOWING DIRECTION OF TRAFFIC AND LOCATION OF THERMISTOR AND RESISTIVITY PROBES. LABEL PROBES "T" AND "R", RESPECTIVELY**

Prepared by: \_\_\_\_\_ Employer: \_\_\_\_\_

Date (dd/mm/yy): \_\_\_\_ / \_\_\_\_ / \_\_\_\_

**Data Sheet SMP-102: Instrumentation Location**

The following procedures are followed for observation piezometer installation (refer to figure II-6); however, deviations to these procedures may be necessary to comply with applicable local regulations.

- (1) Layout the piezometer location.
- (2) Auger to a depth of approximately 4.4 m (14.5 ft) below the ground surface. Keep a log of the bore hole noting material types and layer thicknesses; use Data Sheet SMP-I03.
- (3) Obtain subgrade material samples and place in a 19 L (5 gal) bucket. One sample should be obtained at a depth 1.5 m (5 ft) below the ground surface. If another distinct layer of material is found at a depth less than 1.5 m (5 ft), then another 19 L (5 gal.) sample of this material should be obtained. This material will be used to develop calibration curves between moisture content and dielectric constant for the TDR probes. The lids on 19-L (5-gal) containers should be sealed with tape and the buckets labeled. This material is stored in the RCO until further instructions are issued.
- (4) Center outer sleeve on travel between top of center pipe and lower coupler. Then temporarily tape outer sleeve to center pipe so the sleeve does not move.
- (5) Place cover over the top of the center pipe.
- (6) Place entire piezometer assembly in the hole.
- (7) Place filter sand 0.6 m (2 ft) deep around the bottom of the pipe and compact to the desired depth.
- (8) Place a bentonite layer 0.3 m (1 ft) deep, compact, and add water.
- (9) Backfill and compact material around the pipe to 152 mm (6 in) below the top of the outer sleeve. Be careful not to dislodge the sleeve during compaction. Position metal access cover assembly in hole. Allow a minimum of 152 mm (6 in) between the top of the inner pipe and the access cover. Place portland cement concrete materials around the outside of the access cover. Do not let the concrete come into contact with the inner pipe. Remove tape holding the outer pipe to the inner pipe. Place pea gravel or other suitable material inside the cover to prevent moisture build-up or accumulation inside the access cover.  
Cover top of the inner pipe.

Sensor installation in the pavement structure should follow the procedures described below.

**A. Review target sensor depths**

Review target sensor depth table (Data Sheet SMP-I02). Sensor placement depths may be measured and marked on one of the compaction tools.

**B. Instrumentation hole and trench removal**

- (1) Mark the location of the hole and trench. Paint an arrow on top of the instrumentation hole in the direction of traffic to use during replacement.

|  |  |
|--|--|
| LTPP Seasonal Monitoring Program<br>Data Sheet SMP-I03<br>Log of Piezometer Hole | Agency Code <span style="float: right;">[ ] [ ]</span><br>LTPP Section ID <span style="float: right;">[ ] [ ] [ ] [ ]</span> |
|--|--|

|                                |  |
|--------------------------------|--|
| Operator: _____                | Equipment Used: _____                    |
| Location: _____                | Station: _____                           |
|                                | Offset: _____ . _____ m (from lane edge) |
| Bore Hole Diameter: _____ . mm | Auger Type: _____                        |

| Scale (m) | Depth from Surface <sup>1</sup> (m) | Material Description | Material Code <sup>2</sup> |
|-----------|-------------------------------------|----------------------|----------------------------|
| _ 0.5 _   |                                     |                      |                            |
| _ 1.0 _   |                                     |                      |                            |
| _ 1.5 _   |                                     |                      |                            |
| _ 2.0 _   |                                     |                      |                            |
| _ 2.5 _   |                                     |                      |                            |
| _ 3.0 _   |                                     |                      |                            |
| _ 3.5 _   |                                     |                      |                            |
| _ 4.0 _   |                                     |                      |                            |
| _ 4.5 _   |                                     |                      |                            |
| 5.0       |                                     |                      |                            |

<sup>1</sup> Format: \_\_\_\_\_ m;      <sup>2</sup> Format: \_\_\_\_\_

Prepared by: \_\_\_\_\_ Employer: \_\_\_\_\_

Date (dd/mm/yy):      /      /

A square hole 456 mm by 456 mm (18 in by 18 in) cut with a pavement saw is the preferred access hole in AC pavements, and a 305 mm (12 in) diameter core is preferred for PCC pavements.

Widen the saw cut to the mid-lane in the traffic direction from hole for installation of pavement surface temperature probe [6 mm (0.25 in) O.D.]. Length of the widened cut will depend on surface layer thickness and diameter of the saw blade. The thickness and length of the widened cut should be checked by trial insertion of the pavement surface temperature probe.

Remove asphalt concrete or portland cement concrete surface layer and bound base layers. Anchor bolts may be used for this purpose.

- (5) Remove any excess water from the hole with a large sponge.
- (6) Measure the thickness of the core at four points spaced at equal intervals around the circumference of the core (use SHRP Protocols P01 "Visual Examination and Thickness of Asphaltic Concrete Cores" and P66 "Visual Examination and Thickness of Portland Cement Concrete Cores").  
Alternatively, measure the midpoint thickness of each side if a square piece is removed. Each measurement should be read to the nearest 2.0 mm (0.1 in).  
Cut 76- to 102-mm (3- to 4-in) wide, full-depth trench through the bound pavement surface layers to the edge of the shoulder and remove the AC or PCC surface layer and any bound base layer(s).
- (8) Remove any excess water from the trench with a large sponge.

### **C. Augering operations**

- (1) Auger approximately 152 mm (6 in) at a time through the base layer and approximately 0.3 m (1 ft) at a time through the subgrade to collect material. Where possible, large-flight solid-stem auger should be used. Keep a log of the bore hole noting materials types and layer thicknesses; use Data Sheet SMP-I04. Place material from each layer in separate 19-L (5-gal) buckets, cover buckets with lids, number the buckets, and line the buckets up in order.
- (2) Auger to approximately 2.1 m (7 ft) below the top of the unbound base or bottom of the last bound pavement layer.
- (3) Measure the total depth of the hole from the pavement surface.

### **D. Installation of TDR, thermistor, and electrical resistivity probes**

- (1) Replace and compact material in the hole (in reverse order from extraction) to approximate desired sensor depths.
- (2) Run electrical resistivity probe through conduit prior to placement, since the connector is larger than the conduit.
- (3) Both the thermistor and electrical resistivity probes are positioned with the top of the probes 51 mm (2 in) below the top of the first unbound base layer. Measure the actual depth of the top of each probe from the pavement surface and record on Data Sheet SMP-I02.

|   |  |
|---|--|
| LTPP Seasonal Monitoring Program<br>Data Sheet SMP-I04<br>Log of Instrumentation Hole | Agency Code <span style="float: right;">[ ] [ ]</span><br>LTPP Section ID <span style="float: right;">[ ] [ ] [ ] [ ]</span> |
|---|--|

|                                |                |                       |                    |
|--------------------------------|----------------|-----------------------|--------------------|
| Operator: _____                |                | Equipment Used: _____ |                    |
| Location:                      | Station: _____ | Offset: _____         | m (from lane edge) |
| Bore Hole Diameter: _____ . mm |                |                       |                    |

| Scale<br>(m) | Strata<br>Change <sup>1</sup> (m) | Material<br>Description | Material<br>Code <sup>2</sup> |
|--------------|-----------------------------------|-------------------------|-------------------------------|
| — 0.10 —     |                                   |                         |                               |
| — 0.20 —     |                                   |                         |                               |
| — 0.30 —     |                                   |                         |                               |
| — 0.40 —     |                                   |                         |                               |
| — 0.50 —     |                                   |                         |                               |
| — 0.60 —     |                                   |                         |                               |
| — 0.70 —     |                                   |                         |                               |
| — 0.80 —     |                                   |                         |                               |
| — 0.90 —     |                                   |                         |                               |
| — 1.00 —     |                                   |                         |                               |
| — 1.10 —     |                                   |                         |                               |
| — 1.20 —     |                                   |                         |                               |
| — 1.30 —     |                                   |                         |                               |
| — 1.40 —     |                                   |                         |                               |
| — 1.50 —     |                                   |                         |                               |
| — 1.60 —     |                                   |                         |                               |
| — 1.70 —     |                                   |                         |                               |
| — 1.80 —     |                                   |                         |                               |
| — 1.90 —     |                                   |                         |                               |
| — 2.00 —     |                                   |                         |                               |
| — 2.10 —     |                                   |                         |                               |
| — 2.20 —     |                                   |                         |                               |
| — 2.30 —     |                                   |                         |                               |
| — 2.40 —     |                                   |                         |                               |
| — 2.50 —     |                                   |                         |                               |

<sup>1</sup> Format: \_\_\_\_\_ m;      <sup>2</sup> Format: \_\_\_\_\_

Prepared by: \_\_\_\_\_ Employer: \_\_\_\_\_

Date (dd/mm/yy):      /      /

**Data Sheet SMP-I04: Log of Instrumentation Hole**

- (4) Prior to placing the first TDR sensor (sensor 10) in the bottom of hole, an S-loop approximately 51 mm (2 in) long held in place with a loose plastic tie wrap, should be formed in the wire lead ~ 102 mm (4 in) from the probe. This S-loop is intended to function as a stress relief to mitigate potential effects of frost heave or soil expansion.
- (5) Connect the TDR sensor to the cable tester in manual mode and adjust the cable tester so the probe trace is visible on the screen. The trace is monitored during placement and compaction of material around the probe to detect any damage to the probes. If the trace is lost during placement, typically an open circuit waveform will be displayed at the probe location, and the probe should be removed and replaced with a spare.
- (6) Place the TDR probe in the hole at the desire depth and position the lead wire against the wall of the hole. Measure the depth from the pavement surface to steel rods on the probe and record on Data Sheet SMP-I02. Probe rods should be horizontal.
- (7) Take two moisture samples from material placed around the TDR. Determine the moisture content of one sample in the field and record on Data Sheet SMP-I05. Place the other sample in a suitable sample container and label with section number, date, and TDR sensor number.  
Compact material around TDR sensor carefully using the small compactor and holding lead wires to side of hole; the thermistor and electrical resistivity probes should be protected during compaction with longitudinally cut PVC pipe.
- (9) Add and compact additional material in shallow lifts as needed to reach next desired TDR sensor elevation. If large clay pieces are present, they should be broken by hand prior to placement and compaction. Likewise, if rocks are present in the material, do not place on top of the TDR rods, but around the probe.  
After placing and compacting the material to the elevation of the next sensor, print out a trace of the previously installed sensor. Record the pertinent information on the printout. The trace will be copied onto Data Sheet SMP-I06 along with other pertinent information — e.g., apparent length, dielectric constant, and volumetric moisture content based on Topp's model.  
Repeat steps 4 through 10 for each successive TDR probe. Each probe is rotated about 10° to keep lead wires in one layer along the side of the hole. Continue this process until all TDR probes and material are placed in the hole.  
(Note: TDR probe No. 1 is installed upside down if it is placed less than 380 mm (15 in) below any bound material). Additional material for the hole may be obtained from the piezometer hole, trench, or shoulder as available.
- (12) Place surface temperature probe in the widened cut in the pavement surface.
- (13) Run sensor lead cables through the conduit and place in the trench; conduit should be located directly beneath the AC or PCC surface layer.

|  |  |
|--|--|
| LTPP Seasonal Monitoring Program<br>Data Sheet SMP-I05<br>Field Gravimetric Moisture Content | Agency Code <span style="float: right;">[ ]</span><br><br>LTPP Section ID <span style="float: right;">[ ]</span> |
|--|--|

| TDR Probe | Probe Depth <sup>1</sup> (m) | Moisture Sample No. | Pan No. | Wt. of Pan (gms) = A | Wt. of Pan + Wet Soil (gms) = B | Wt. of Pan + Dry Soil (gms) = C | Wt. of Dry Soil (gms) = D = C - A | Wt. of Water (gms) = E = B - C | Moisture Content (%) = $w = E/D * 100$ |
|-----------|------------------------------|---------------------|---------|----------------------|---------------------------------|---------------------------------|-----------------------------------|--------------------------------|--|
| 1         | _____                        | _____               | _____   | _____                | _____                           | _____                           | _____                             | _____                          | _____                                  |
| 2         | _____                        | _____               | _____   | _____                | _____                           | _____                           | _____                             | _____                          | _____                                  |
| 3         | _____                        | _____               | _____   | _____                | _____                           | _____                           | _____                             | _____                          | _____                                  |
| 4         | _____                        | _____               | _____   | _____                | _____                           | _____                           | _____                             | _____                          | _____                                  |
| 5         | _____                        | _____               | _____   | _____                | _____                           | _____                           | _____                             | _____                          | _____                                  |
| 6         | _____                        | _____               | _____   | _____                | _____                           | _____                           | _____                             | _____                          | _____                                  |
| 7         | _____                        | _____               | _____   | _____                | _____                           | _____                           | _____                             | _____                          | _____                                  |
| 8         | _____                        | _____               | _____   | _____                | _____                           | _____                           | _____                             | _____                          | _____                                  |
| 9         | _____                        | _____               | _____   | _____                | _____                           | _____                           | _____                             | _____                          | _____                                  |
| 10        | _____                        | _____               | _____   | _____                | _____                           | _____                           | _____                             | _____                          | _____                                  |

<sup>1</sup> Distance in meters from pavement surface to TDR probe

Comments: \_\_\_\_\_  
 \_\_\_\_\_  
 \_\_\_\_\_

Prepared by: \_\_\_\_\_ Employer: \_\_\_\_\_

Date (dd/mm/yy): \_\_\_ / \_\_\_ / \_\_\_

|  |  |
|--|--|
| LTPP Seasonal Monitoring Program<br>Data Sheet SMP-106<br>TDR Moisture Content | Agency Code <span style="float: right;">[ ]</span><br>LTPP Section ID <span style="float: right;">[ ]</span> |
|--|--|

**Required Settings:**

Dist./Division: 0.25 m  
 Phase Velocity: 0.99  
 Noise Filter: 1 average

| Probe Number | Probe Depth <sup>1</sup> (m) | Time (military) | Apparent Length (m) | Dielectric Constant <sup>2</sup> | Comments |
|--------------|------------------------------|-----------------|---------------------|----------------------------------|----------|
| 1            | __ . ____                    | _____           | __ . ____           | ____ . ____                      |          |
| 2            | __ . ____                    | _____           | __ . ____           | ____ . ____                      |          |
| 3            | __ . ____                    | _____           | __ . ____           | ____ . ____                      |          |
| 4            | __ . ____                    | _____           | __ . ____           | ____ . ____                      |          |
| 5            | __ . ____                    | _____           | __ . ____           | ____ . ____                      |          |
| 6            | __ . ____                    | _____           | __ . ____           | ____ . ____                      |          |
| 7            | __ . ____                    | _____           | __ . ____           | ____ . ____                      |          |
| 8            | __ . ____                    | _____           | __ . ____           | ____ . ____                      |          |
| 9            | __ . ____                    | _____           | __ . ____           | ____ . ____                      |          |
| 10           | __ . ____                    | _____           | __ . ____           | ____ . ____                      |          |

<sup>1</sup> Distance in meters from pavement surface to TDR probe

<sup>2</sup> Dielectric constant is determined as follows:

$$\epsilon = \left[ \frac{L_a}{(L)(V_p)} \right]^2 = \left[ \frac{(D_2 - D_1)}{(L)(V_p)} \right]^2$$

where  $\epsilon$  = dielectric constant;  $L_a$  = apparent length of probe, m;  $L$  = actual length of probe units (= 0.203 m (8 in) for FHWA probes);  $V_p$  = phase velocity setting (= 0.99).

**ATTACH TDR TRACES TO THIS DATA SHEET.**

Comments: \_\_\_\_\_  
 \_\_\_\_\_  
 \_\_\_\_\_

Prepared by: \_\_\_\_\_ Employer: \_\_\_\_\_

Date (dd/mm/yy):        /        /

### **E. Installation of equipment cabinet**

The equipment cabinet should be positioned approximate 9.1 m (30 ft) offset from the edge of the driving lane. After placing TDR No. 10 (deepest probe) in the bottom of the hole, position the cabinet so a minimum of 1.2 m (4 ft) of wire from this sensor will extend up into the cabinet. This will allow connection to the mobile data recording unit. A hole ~508 mm (20 in) deep (ground line marked on cabinet), and a little larger than the base of the cabinet, should be dug at this location. A trench leading from the pavement should be dug approximately 0.3 m (1 ft) deep. At the cabinet, the trench is deeper to allow a smooth bend in the conduit. A trench approximately 0.3 m (1 ft) below the bottom of the cabinet should also be dug to the air temperature/rain gauge probe support pole location. As an alternative, a conduit from the pole into the back of the cabinet can be used above ground.

In some locations, a drainage trench from the bottom of the cabinet to a lower elevation is required to prevent accumulation of run-off water in the cabinet. This trench should be filled with pea gravel. The two support legs for the cabinet should be driven on the sides of the cabinet hole to the proper elevation. The legs can be attached either inside or outside of the cabinet. Attach the cabinet with the two bolts provided per leg. After all sensor wires have been run through both conduits, place the conduits approximately 457 mm (18 in) above the ground line up into the cabinet. Fill the bottom of the cabinet with a 305-mm (12-in) deep layer of pea gravel. A standard electrical grounding rod is driven adjacent to the equipment cabinet. The grounding strap inside the cabinet is run through one of the rubber grommets and attached to the grounding rod with a brass clamp.

### **F. Installation of air temperature probe and rain gauge**

The support pole for the air temperature probe and rain gauge should be positioned within 0.9 m (3 ft) behind the equipment cabinet. The pole must extend below frost line, and a 152-mm (6-in) diameter hole is augered at least 0.3 m (1 ft) deeper than the desired bottom of the support pole. The bottom of this hole is filled with pea gravel to the desired elevation of the bottom of the support pole. The support pole with a floor flange is placed on this layer and compacted as close to vertical as possible. Next, place and dry pack portland cement concrete mix (commercially available sackcrete) around the pipe in the hole to an elevation of ~0.3 m (1 ft) below ground level or, in frost areas, just below frost line. A small quantity of water may be added to the top of the PCC to promote strength gain, although over time the concrete should cure with in situ pore water.

Assemble the remaining top support structure and attach the probes. Run the probe wires through the holes and down the center of the support pipe. Use silicone caulk or a rubber grommet to seal the holes where the wires enter the pipe. Tape the lead wire or enclose in plastic loom at bend locations to provide additional protection against chaffing. Position support pipe near the base pipe. Run lead wire through the

center of the base pipe and out the hole below ground at the conduit location. An electrical conduit-pipe coupler should be used where the wires exit the base pipe. Position the support pipe over the base pipe while maintaining tension on the lead wires so they remain clear of the pipe union. Secure the top support assembly to the bottom support using 51 mm (2 in) union. Check pipe and adjust to as near vertical as possible. Run the lead wire through conduit attached to the base pipe. Back fill the remaining hole with native material and compact. An alternative to running lead wire below ground is to run conduit above ground into back of cabinet if support pipe is within 152 mm (6 in) of cabinet.

If the air temperature lead wire needs to be lengthened, it must be spliced approximately 0.3 m (1 ft) from the connection end of the wire where a resistor is contained in the black plastic insulation. The splice wire should be the same type used on the probe (Beldon Type 8641, paired Beldfoil shielded cable, 24 AWG(7x32) with polyethylene insulation). PVC insulated wire should **not** be used with this probe. Instead, teflon insulated hook-up wires (stranded 16 to 18 AWG) should be used between the terminal strip and the CR10 datalogger for this probe. A connector should **not** be installed on the lead wire to the air temperature probe.

#### **G. Pavement patching and site clean-up**

For patching of AC pavements, PC-7 or PC-11 epoxy or equivalent is an acceptable rapid setting material for bonding the block or core back in place using the following procedure:

- (1) Clean the sides of the hole with a wire brush.
- (2) Level and compact the base material even with the bottom of the hole to the shape of the bottom surface of the AC block or core.
- (3) Test place the block or core in the hole using original orientation to check that surface elevations match. Adjust the elevation of the base material until the surface elevations match and the replacement block or core does not rock.
- (4) Remove the block or core and clean the sides with a wire brush.
- (5) Use epoxy to position and fix the pavement temperature metal rod in the widened saw cut. Work material beneath the steel rod to provide firm support, measure depth of each end of the probe and record on Data Sheet SMP-I02.
- (6) Mix and apply epoxy to the edges of the block or core. Carefully replace the AC piece into the hole and seat firmly using the wheels of a truck. Use a trowel to smooth any epoxy on the pavement surface and form groove 13 to 19 mm (0.5 to 0.75 in) deep for crack sealant.
- (7) Place low modulus AC crack sealant in grooves around the perimeter of the instrumentation hole. Toilet paper can be used on low modulus sealants to prevent tracking from vehicle tires.

Patch the trench using an asphalt concrete patch material. Sides of the trench should be cleaned with a wire brush. The asphalt concrete patch material should be placed and compacted in 51 mm (2 in) lifts.

Allow the epoxy to cure for at least 1 h prior to application of traffic.

Two alternatives for patching PCC pavements are provided. One is to replace the block or core in a similar fashion as for AC pavements. The other is to patch the PCC pavement using rapid set patch that develops about 6.9 MPa (1,000 psi) compressive strength in about 1 h at 22 °C (72 °F). Use the following procedure if the latter alternative is selected.

- (1) Clean the core hole and trench with a wire brush to remove any loose material. If desired, sand blast to promote bonding. A latex bonding agent can also be applied.
- (2) Use a sand based PCC rapid set repair material to bond the pavement surface temperature probe in the widened saw cut. Work material beneath the steel rod to provide firm support, measure depth of each end of the probe and record on Data Sheet SMP-I02. Fill the groove on top of the probe with this material.
- (3) Block out the gap created by the conduit trench.
- (4) Following manufacturer's instructions, mix and place the rapid setting patch concrete material in the core hole and level. A portable concrete mixer should be used because of the quantity of material required. A low slump material should be used. This material can be extended with clean pea gravel.
- (5) Fill the conduit trench with the same material by blocking off portions of the trench to reduce movement of the material to the outside edge of the pavement.
- (6) Allow the patch material to set for at least 1 h prior to opening to traffic.

It is imperative that the pavement surface be restored to a water-tight condition. Once done, the last required activity for the first day is site clean-up.

Prior to leaving the site the first day, the installation team leader must record serial reference numbers for the instruments installed and names of participants on Data Sheet SMP-I01 and record all sensor locations on Data Sheet SMP-I02. An effort should be made to complete wiring on the first day and run the ONSITE program overnight. On rigid pavements, an effort should also be made to install snap rings on the first day so that a full round of FWD and joint opening measurements can be made the second day.

### Second Day Activities

As with the first day, all participants are expected to be at the site by 8:00 a.m., so that traffic control can be ready by 8:30 a.m. Details of the monitoring activities are presented

later in this document; their conduct is expected to last a full 8-h day. In addition to referenced activities, all debris at the site should be cleaned up prior to departing the site.

Activities on the second day focus on collection of the first "complete" round of seasonal monitoring data — instrumentation measurements, deflection testing, elevation surveys, etc. The only exceptions are the completion of any remaining equipment wiring and, in the case of PCC pavements, installation of internal snap rings at the joints. Completion of the equipment wiring consists of connecting the thermistor probe, air temperature probe and tipping bucket rain gauge to the terminal strip. The electrical resistivity probe connector and TDR probe lead wires should be secured in the back of the cabinet.

The internal snap rings in PCC pavements are for measuring joint movement. These thin rings provide sharp edges for caliper jaws to minimize errors from rotation of caliper; i.e., they provide for high repeatability on location and measurement accuracy. The installation procedure is as follows:

- Measure out and mark locations for drilling holes as shown in figure II-14. At each test joint, pairs of snap rings will be installed at 0.3, 1.8, and 3.4 m (1, 6, and 11 ft) from the outside pavement edge and 64 mm (2.5 in) away from the joint center. The edge reference is the lane-shoulder interface on a normal paving lane (usually 3.7 m (12 ft) wide lane) and the outside edge of the painted shoulder stripe on a wide paving lane (usually 4.0 m (13 ft) wide lane or greater). If the outside edge of the painted shoulder stripe is over 152 mm (6 in) inside the lane-shoulder interface, then use the outside edge of the painted shoulder stripe as the edge reference. If the lane-shoulder interface is inside the painted shoulder stripe, the interface should be used as the edge reference.
- Carefully drill 13-mm (0.5-in) diameter holes 13 mm (0.5 in) deep using drill guide to control spacing between each pair of holes (prevent bit wander and excess chipping around the hole), to maintain holes perpendicular to the pavement surface and each other, and to control maximum hole depth.
- Test fit snap ring in hole. Ring must be at least 9.5 mm (0.375 in) below the PCC surface. In some cases, snap rings will have to be set deeper if hole chips or deep texture in the surface interferes with hole; see figure II-14.
- Remove snap ring and clean dust from hole.
- Coat inside of hole with thin film of silicon sealer/adhesive formulated for use on PCC pavement.

Insert snap ring to appropriate depth below pavement surface.

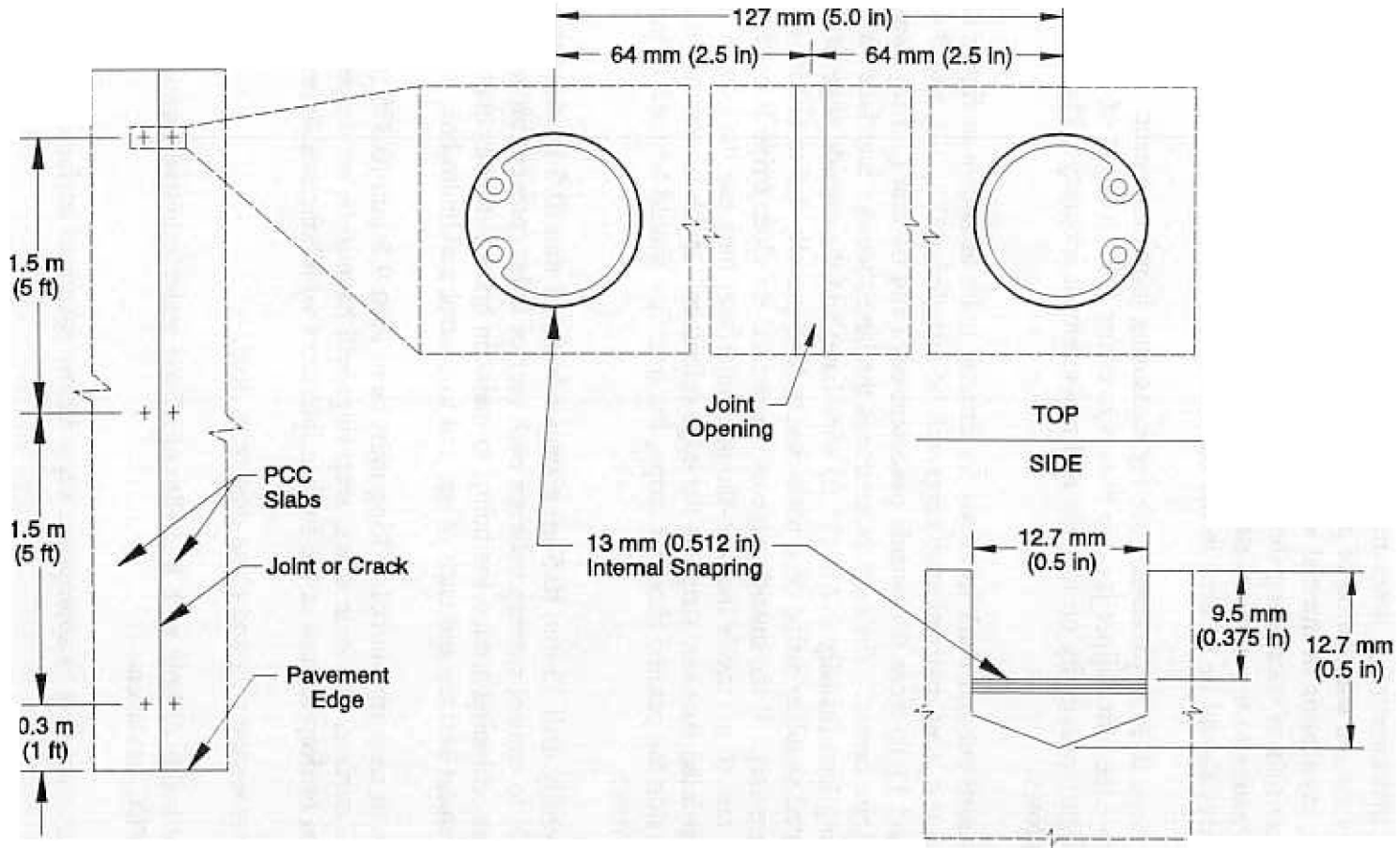

**Figure II-14 - Snap Ring Placement for Measuring Joint Openings - PCC Pavements**

- Fill any space more than 2.5 mm (0.1 in) below snap ring with silicon to help prevent debris from filling hole or freezing moisture from forcing snap ring out of position.

## Post-Installation Activities

Shortly after completion of installation, the RCOC's should send the participating highway agency a "Thank you" letter for their participation and assistance. The RCOC's should also begin planning and scheduling future monitoring activities performed on a monthly, and sometimes more frequent, basis.

Within 2 months after installation, the RCOC's must also prepare an "Installation and Initial Data Collection" report using the following set of guidelines for each seasonal site. Unless otherwise advised by the FHWA-LTPP Division, the RCOC's should strictly adhere to the guidelines.

### Report Submittal and Distribution

Copies of this report should be sent to FHWA-LTPP Division and its TAC (PCS/Law Engineering) for review and approval, prior to further distribution. On approval, copies of the report should be sent to the site installation participants.

### Report Contents

Each report shall consist of the sections listed in table II-10 in the order given. The contents of each section as well as the maximum allowable number of pages for each one are also specified in table II-10. The main report should not exceed 15 pages; supporting information should be included in appendixes A through D of the report.

If RCOC personnel go back to the site after the installation, but prior to the submittal of the report, they should assess the condition of the pavement patch/repair and include their assessment in the report under section II.b. An assessment of the patch/repair area should be conducted during every site visit and, if for some reason it is not performing well, appropriate highway agency and FHWA-LTPP personnel should be advised of the situation so that corrective measures can be taken.

### Report Format

All reports should conform with FHWA reporting requirements, except that SI units (only) are now mandatory — see "Guidelines for Preparing Federal Highway Administration Publications," Report No. FHWA-AD-88-001, January 1988.

**Table II-10 - Seasonal Report Contents**

| Section  | Contents   | Max. No. Pages |
|--|--|----------------|
| I.<br>Introduction   | <p>a. Detailed description of test site: location, pavement type, seasonal cell, climatic conditions, traffic lanes and volume, uniformity, etc.</p> <p>b. Summary information of the pavement layer types and depths as determined from the previous GPS drilling and sampling, and those determined from the bore hole log. Also include dry densities of the various unbound pavement layers and subgrade as determined from the test pits or estimated by the laboratory.</p> <p>c. Date of installation and installation team (including roles, responsibilities, and agencies).</p> <p>Note: supporting information such as drilling and sampling data, deflection profiles from FWDCHECK, distress data, site pictures, maps, etc., should be included in appendix A.</p>   | 2              |
| II.<br>Instrumentation<br>Installation                           | <p>a. Summary of pre-installation activities</p> <ul style="list-style-type: none"> <li>● meetings with highway agency and site visits (date and purpose).</li> <li>● list all sensors installed including serial numbers.</li> <li>● instrumentation checkout procedures.<sup>1</sup></li> <li>● location of instrumentation; and reasons for selecting location, if different than specified in guidelines.</li> </ul> <p>Note: Supporting information such as meeting agendas, site visit pictures, data sheets for instrument checkout procedures, pictures of sensors, etc., should be in appendix B.</p> <p>b. Summary of installation activities.</p> <ul style="list-style-type: none"> <li>● general schedule of installation activities.</li> <li>● installed depths of all in-pavement sensors with the pavement surface used as the reference.</li> <li>● brief description of piezometer installation.<sup>1</sup></li> <li>● brief description of instrumentation hole installation<sup>1</sup> plus tabular summary of field gravimetric versus manual TDR moisture contents.</li> <li>● brief description of equipment cabinet installation.<sup>1</sup></li> <li>● brief description of climatic sensor installation.<sup>1</sup></li> <li>● brief description of pavement repair.<sup>1</sup></li> <li>● brief assessment of pavement repair condition (if additional site visit prior to report).</li> </ul> <p>Note: supporting information such as moisture content data, field TDR traces, installation pictures etc., should be included in appendix C.</p> | 8              |
| III.<br>Initial Data<br>Collection                               | <p>a. Brief summary of FWD deflection testing.<sup>1</sup></p> <p>b. Brief summary of elevation and profile (if done) surveys.<sup>1</sup></p> <p>c. Brief summary of joint opening measurements, where applicable.<sup>1</sup></p> <p>d. Brief summary of moisture, temperature, and frost/thaw depth measurement.<sup>1</sup></p> <p>e. Brief summary of distress survey (if done).<sup>1</sup></p> <p>Note: supporting information such as data sheets completed as part of the data collection activities, data collection photographs, etc., should be included in appendix D.</p>  | 3              |
| IV.<br>Summary,<br>Conclusions,<br>and<br>Recommended<br>Changes | <p>Highlights of site instrumentation installation, including problems encountered and how they were resolved (if resolved) and recommendations for improvement of the installation process based on experiences at the site.</p>  | 2              |

<sup>1</sup>If done according to protocol, state so, do not go into details; if not, describe variations, problems, and/or reasons.

## *INSTRUMENTATION OPERATION GUIDELINES*

### Manual Data Acquisition

#### TDR Sensors

##### *Preparation:*

- a. Make sure batteries on Tektronix 1502B cable reader are fully charged prior to site arrival because of large power demands of the heat sensitive printer for the cable tester. Use of a small portable generator to supply power is recommended; vehicle inverters may cause excessive noise in the TDR signal.
- b. Replace the SDM1502 communication interface with the YT-1 strip chart recorder.
- c. Replace the PS1502B power module with the 1502B-03 battery pack.

##### *Setup:*

- a. Pull on the power switch. The instrument will initialize, give instructions for accessing the menu, and enter the "Normal Operation" mode.
- b. Using the setup menu, set the 1502B for metric distance divisions.
- c. Discharge any static electricity prior to connecting probes to cable tester; uncoil the test lead that goes from the cable tester to probe leads.
- d. Attach the BNC connector from probe 1 (10 if installing probes) and set the 1502B front panel switches to the following positions:

|                   |           |
|-------------------|-----------|
| Noise Filter      | 1 average |
| Vert. Scale       | 75 mp/div |
| Dist/Div (metric) | 0.25 m    |
| VP                | .99       |

- e. Adjust the horizontal position. Move the vertical cursor to 0.0 m. The cursor will be at the point of the trace representing the BNC connector on the front panel. Using the  $\Delta \nabla$  position control, adjust the horizontal reference line so that the trace is centered on the screen.
- f. Turn the  $\triangleleft \triangleright$  position control clockwise until the first peak of the TDR trace is aligned with the second or third vertical line from the left. Align cursor so that it rests on the peak of the TDR probe trace. This length will generally be approximately 18.5 m (60 ft).

- g. After locating the probe wave form, the VERT SCALE Control (mp/div) or the DIST/DIV control should be adjusted so the trace representing the probe occupies most of the screen; however, it is preferable to maintain the same scale/units for all 10 probes.
- h. To print the trace:
  - 1) Make sure the desired trace is displayed on the screen.
  - 2) Slide open the chart recorder door until it locks in place and push print on the front panel of the chart recorder.
  - 3) When the chart recorder has finished, tear off the paper by pulling it to the left.

Record the date, time, probe number and test section number in the appropriate locations on the right margin of the trace. Under "Notes" include comments about installation, material around probe, etc.

- j. Repeat steps f through i for all 10 probes.
- k. Use Data Sheet SMP-I06 or SMP-D01 to record results, as appropriate.

#### Thermistor Probe

- a. Connect the test jig alligator clip leads for the RD100 or RD200 readout unit to the corresponding color coded wires on the terminal strip for the TP101 probe.
- b. Connect the RD100 or RD200 temperature readout unit to the test jig plug.
- c. Turn on the readout unit, and use the channel selector to display temperature outputs for each sensor. Use Data Sheet SMP-D02 to record the date, time, and temperature for all 18 sensors. The readings must be registered and recorded fairly rapidly to avoid generating heat in the thermistor circuit.

#### Electrical Resistivity Probe

##### *Set-up:*

- a. Remove connector cover and connect cable from the electrical resistivity probe cable to the switch box.
- b. Check lead wire continuity on each multimeter by setting the meter to  $\Omega$  function, connecting the two test leads together, and wiggling test lead wire

connections. There should be no change in the meter response when the wires are wiggled. If continuity is lost while wiggling, this may indicate an open in one of the test leads. Confirm by reconnecting the test leads and repeating the test. If an open is indicated, replace the test leads.

- c. Connect the function generator, ammeter, and voltmeter to the proper connectors on the switch box. Connect test leads to the proper terminals on the multimeters. Confirm that the  $600\Omega$  output, or other loaded output, of the function generator is used and not the TTL output.
- d. Set the function generator to produce a 100 Hz square wave with the largest possible amplitude (10V p-p). Set the DC offset to the "off" position. If the function generator has an attenuator, typically a 30 dB attenuator, set this switch to the "off" position.
- e. Set the digital multimeter used as the ammeter (DMM #1 in figure II-5.A), to AC amperage. This is indicated on some multimeters as ACA or A~. Verify that the test leads are plugged into the correct amperage measurement sockets on the meter. One socket will be designated COM and the other  $\mu\text{A}$  or A. Use the lowest amperage rated socket on the meter. If the multimeter is manual ranging, set the selector switch to the lowest amperage range setting without out of range (OL) indication, typically  $200\ \mu\text{A}$ .
- f. Set the digital multimeter used as a voltmeter (DMM #2 in figure II-5.A), to AC voltage. This is indicated as ACV or V~ on most meters. Verify that the test leads are plugged into the proper voltage sockets. One socket will be labeled COM and the other V• $\Omega$ . On manual ranging multimeters, set the selector switch to the lowest AC voltage range without out of range (OL) indication.

*Contact Resistance Measurements (2-point):*

- a. Position the knobs on the switch box so that  $V_1$  and  $I_1$  are connected to electrode 1 and  $V_2$  and  $I_2$  are connected to electrode 2. (**Note:** do not connect  $I_1$  and  $I_2$  to the same electrode at the same time as this could damage the ammeter).
- b. Record the AC current and voltage readings with corresponding range setting on Data Sheet SMP-D03 (see Chapter III - Seasonal Monitoring Data Collection) for test position 1 (electrodes 1 and 2). Current readings will typically be between 1 mA ( $1 \times 10^{-3}$  A) and  $10\ \mu\text{A}$  ( $1 \times 10^{-6}$  A). Voltage readings will typically be between 500 mV and 10 mV. These ranges can vary depending on the power output of the function generator and electrical resistivity of material around the probe.

Note: after placing switches in proper position, voltage and current may drift, typically decreasing over time. If this occurs, the operator should wait until the rate of change of the readings slows down so that an instantaneous reading of both voltage and current can be made. On very sensitive multimeters, the rate of change can be reduced by switching to a less sensitive scale. In all cases, a reading with three significant digits should be made.

- c. Next switch the box so  $V_1$  and  $I_1$  connect to electrode 2 and  $V_2$  and  $I_2$  connect to electrode 3. Record the voltage and amperage readings as position 2 on the data sheet.
- d. Repeat Step c switching  $V_1$ - $I_1$  and  $V_2$ - $I_2$  connects in a step wise manner, and record voltage and amperage readings.
- e. The last four readings for test position 36 to 39 are check resistors. The measured voltage and current is used to compute the electrical resistance in the field and compare it to known values for the check resistors (see equation 5).

*Four-Point Electrical Resistivity Measurements (4-point):*

- a. Start by switching  $I_1$  to electrode 1,  $V_1$  to electrode 2,  $V_2$  to electrode 3, and  $I_2$  to electrode 4. Record the voltage and amperage readings on Data Sheet SMP-D04 on the test position 1.

Note: after placing switches in proper position, voltage and current may drift, typically decreasing over time. If this occurs, operator should wait until the rate of change of the readings slows down so that an instantaneous reading of both voltage and current can be made. On very sensitive multimeters, the rate of change can be reduced by switching to a less sensitive scale. In all cases, a reading with three significant digits should be made.

- b. Next switch the position of each connection to the next higher electrode number and record the voltage and amperage readings.
- c. Continue with Step b until the last measurement with  $I_2$  connected to electrode 36 is made.
- d. Measure the check resistors as done in Step e above using the contact (electrical) resistance technique.

## Automated Data Acquisition

Two Campbell Scientific CR10 dataloggers are used to collect data from the instrumentation installed at a seasonal monitoring site. Software for the dataloggers is provided in two basic

modules - ONSITE and MOBILE. Each module may be configured to use a variety of sensors. These modules may be modified with the EDLOG editor, which creates a "*module.DOC*" file containing the documented source code and a "*module.DLD*" file to download the code to the datalogger for execution.

The ONSITE and MOBILE modules should require little, if any, modification. If modification is required (e.g. to enable optional sensors, change reporting times or calibration coefficients), the EDLOG section of the "*PC208 DATALOGGER SUPPORT SOFTWARE INSTRUCTION MANUAL*" must be consulted. These modules, when downloaded to the appropriately configured datalogger, direct the datalogger to collect data (e.g. temperatures, precipitation ...) at precise intervals or times. The collected data is manipulated (e.g. averaged or summed over a time period) and saved in the internal memory of the datalogger for subsequent uploading to a personal computer.

Both modules have the ability to collect data from the following basic sensors:

- The Campbell Scientific Model # 107-L temperature probe used to measure air temperature.  
  
The Texas Electronics Model # TE525MM tipping bucket rain gauge used to measure precipitation.
- The MRC Model # TP101 thermistor probe used to measure soil temperature at various depths (18 thermistors).

These sensors are normally activated for the ONSITE module for continuous data collection at the seasonal sites. In addition, the MOBILE module has the ability to collect TDR traces using a Tektronix PS1502B metallic cable tester and SDMX50 coax multiplexer with FHWA TDR sensors. TDR probe measurements require a special software PROM for the CR10 datalogger. The MOBILE module is designed to use this special software PROM while the ONSITE module is not. Compilation errors will result if the MOBILE module is downloaded to a CR10 datalogger which is not equipped with the special software PROM.

In addition to the basic sensors, two other sensors are available and can be enabled in either of the software modules:

- The CRREL Electrical Resistivity Probe and Multiplexer used to measure voltages across adjacent electrode pairs to determine soil phase changes (freeze/thaw conditions).
- The Geokon Vibrating Wire Pressure Sensor and Campbell Scientific Model AVW1 Vibrating Wire Sensor Interface used to determine the water table level.

Frost penetration (CRREL Electrical Resistivity Probe) and water table level (manual measurement) are normally collected during the site visits (in conjunction with FWD testing),

but for some specific sites with numerous freeze/thaw cycles and/or highly variable water tables, this information can be collected on a continuous basis by connecting the above mentioned sensors to the ONSITE datalogger.

Aside from the ability to collect TDR waveforms, the primary difference between the ONSITE and MOBILE modules is that the ONSITE module operates on a fixed time schedule (data is saved at specific times) while the MOBILE module operates on an elapsed time schedule (data is saved at specific elapsed times since the program was started).

The ONSITE module controls data collection at permanent sites using a standard CR10 datalogger. Data is collected at these sites continuously and saved at specific times of the day. The results are uploaded to a notebook computer approximately once a month. The ONSITE module directs the collection of some or all of the following data:

- Air temperature (sampled every 1 min). The average air temperature is saved both hourly and daily. The maximum and minimum air temperatures and times are saved daily.
- Precipitation (checked every 1 min). The total precipitation is saved both hourly and daily.
- Soil temperatures (sampled every 1 min). The average soil temperatures for the first five thermistors are saved hourly. The average soil temperatures for all thermistors are saved daily. The maximum and minimum soil temperatures and times for all thermistors are saved daily.
- Electrical resistivity probe voltages (if applicable) are read and saved every 4 h.
- Water table level (if applicable - sampled every 1 min). The average, minimum, and maximum water table levels and times are saved every 4 h.

The MOBILE module controls data collection during site visits using a CR10 datalogger equipped with the special software PROM. Data is collected at these sites over a period up to 20 h and saved at specific elapsed times from the start of the program. The results are uploaded to a notebook computer at the end of the period. The MOBILE module is typically activated to collect the following data:

- TDR probe traces are read and saved every 4 h. Initial readings are taken 5 min after the program is started.
- Electrical resistivity probe voltages are saved every 4 h starting 1 min after the program is started.

Additionally, MOBILE can be activated to collect other instrument data as listed below. This may be necessary if an ONSITE datalogger is not permanently installed at the site.

- Air temperature (sampled every 1 min). The average air temperature is saved both hourly and every 8 h. The maximum and minimum air temperatures and times are saved every 8 h.
- Precipitation (checked every 1 min). The total precipitation is saved both hourly and every 8 h.
- Soil temperatures (sampled every 1 min). The average soil temperatures for the first five thermistors are saved hourly. The average soil temperatures for all thermistors are saved every 8 h. The maximum and minimum soil temperatures and times for all thermistors are saved every 8 h.
- Water table level (if applicable - sampled every 1 min). The average water table level is saved every 4 h. The minimum and maximum water table levels and times are saved every 4 h.

Various steps are required to collect seasonal data using the ONSITE and MOBILE dataloggers, including software installation, site setup, and operation of Procedure manager software. These steps are detailed in Appendix B, Automated Data Acquisition.



### III. SEASONAL MONITORING DATA COLLECTION

The SMP involves more frequent collection of pavement data than currently collected as part of routine LTPP monitoring — deflection, profile, and distress. Additional data elements collected which are not routine LTPP monitoring include surface elevations, ambient temperature, precipitation, subsurface moisture, subsurface temperature, frost depth and ground water table elevation. Detailed data collection guidelines for these data elements are provided in this section.

#### *DEFLECTION DATA*

##### Core Experiment

Deflection data at each of the core experiment sites will be collected exclusively with LTPP FWD's. In many respects, the FWD deflection testing procedure is identical to that currently used for GPS sites; refer to Manual for FWD Testing in the LTPP Study, Version 2.0, April 1993. Major changes to this procedure include the number of test points, number of test cycles per day, and annual test frequency.

Figure III-1 illustrates the test pattern for asphaltic concrete (AC) pavements; both outer wheel path and mid-lane locations are tested. The lateral location (distance from edge reference) of test points is determined according to procedures specified in the LTPP Manual for FWD Testing. Along each pass, nine points at 7.6 m (25 ft) spacings are tested. The first test location will conform with station 0+00 or 3+00, depending on the section end selected for seasonal monitoring. Three additional locations in the vicinity of the instrumentation are also tested; two test points in the outer-wheel path and one mid-lane test point. The longitudinal location of these test points depend on the instrumentation hole location. FWD measurements are not taken directly over the instruments to prevent possible damage to the instrumentation. As a minimum, the FWD load plate should be 1.2 radial meters (4 radial feet) away from any instrumentation, borehole or test pit, except for the mid-lane test which is about 1 m (3 ft) from the instrumentation.

The testing pattern for jointed plain (JPC) and jointed reinforced (JRC) concrete pavements is illustrated in figures III-2 and III-3, respectively. For both pavement type, four adjacent effective slabs within the test section are evaluated for mid-slab basin, corner, edge basin and load transfer deflection (5 tests per panel). The effective slabs and lateral location (distance from reference edge) of test points is determined according to procedures specified in the LTPP Manual for FWD Testing. Load transfer deflection tests, both approach and leave, are conducted on five successive joints within the test section as shown in figures III-2 and III-3.

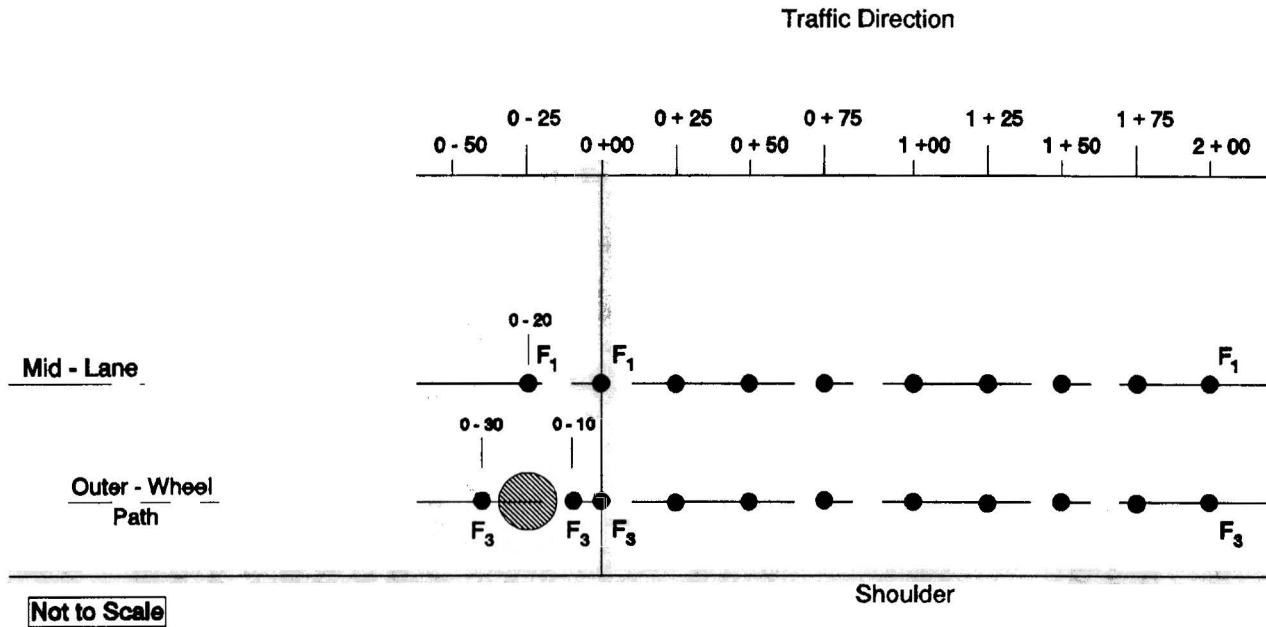

- Location of Deflection Basin Tests
- ⊗ Instrumentation Area

- Notes:**
- (1) Three additional sets of FWD tests will be performed in the vicinity of the instrumentation. The F1 test should be at the same station as the instrumentation hole and the F3 tests should be at stations 1.5 to 3.0 m (5 to 10 ft) from the instrumentation hole.
  - (2) Avoid installing the instrumentation in the vicinity of the original GPS bulk sampling locations.
  - (3) The other section end can be used instead of beginning portion; e.g., test section between stations 3 + 00 and 5 + 00 and instrumentation at station 5 + 20.
  - (4) Location of instrumentation adjusted from 3.0 to 6.1 m (10 to 20 ft) outside section limit to keep at least 1.3 m (4 ft) away from cracks in pavement (see figure II - 12).

**Figure III-1 - Deflection Data Collection Plan - AC Pavements**

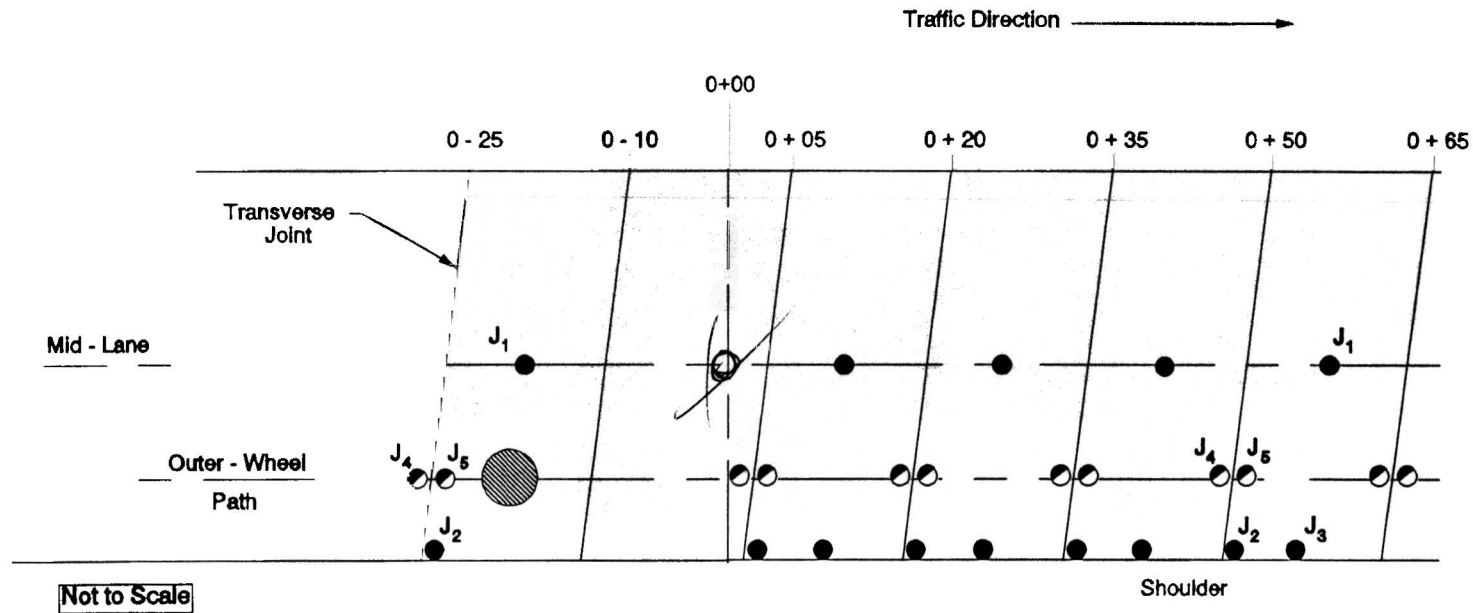

- Location of Deflection Basin Tests (mid - lane and edge)
- Location of Load Transfer Deflection Tests
- Instrumentation Area

- Notes:**
- (1) One set of mid - slab, edge and load transfer deflection tests is performed on the slab with instrumentation . (No J3)
  - (2) The instrumentation should never be installed in the vicinity of the original GPS bulk sampling locations or within 1.5 m (5 ft) of joints.
  - (3) The other section end can be used instead of beginning portion; e.g., test section between stations 4 + 40 and 5 + 00 and instrumentation at station 5 + 15.
  - (4) Above layout assumes 4.6-m (15-ft) slab length. Distances will vary with different slab lengths.

**Figure III-2 - Deflection Data Collection - JPC Pavements**

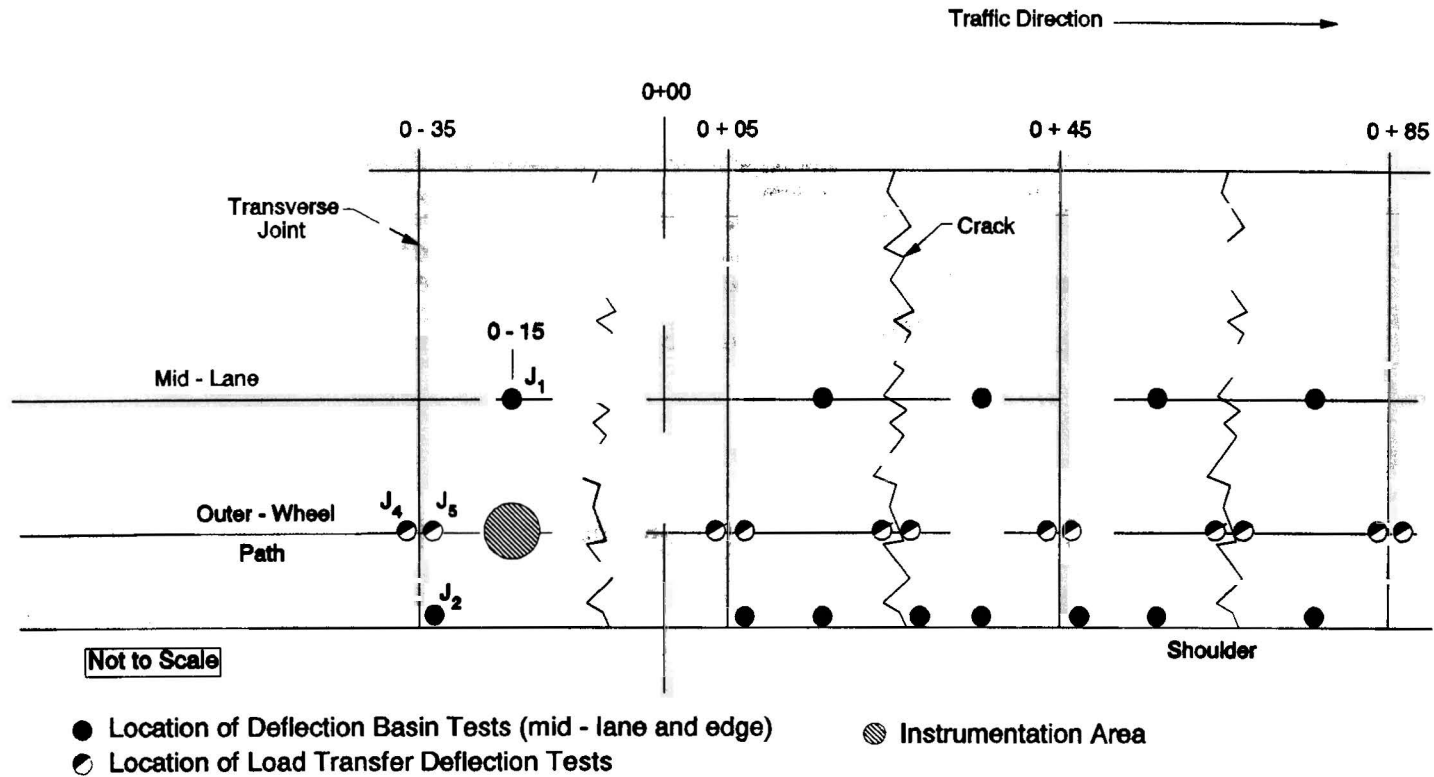

- Notes:**
- (1) One set of mid - slab, edge and load transfer deflection tests is performed on the slab with instrumentation. (No J3)
  - (2) Avoid installing the instrumentation in the vicinity of the original GPS bulk sampling locations.
  - (3) The other section end can be used instead of beginning portion; e.g., test section between appropriate stations 4 + 20 and 5 + 00 and instrumentation at station 5 + 20.
  - (4) Above layout assumes 12.2-m (40-ft) slab length with midpanel cracks creating two "effective panels" from each original slab. Distances will vary with different slab lengths.

**Figure III-3 - Deflection Data Collection Plan - JRC Pavements**

Depending on which section end is selected, the location of the first joint will typically be between station 0+00 and 0+20 or the location of the last joint will typically be between station 4+80 and 5+00. Also, J1, J2, J4 and J5 deflection tests are performed on the effective slab with instrumentation, outside the test section boundaries; no J3 deflection tests are conducted because of trench and location of bore hole. No FWD measurements are taken directly over the instruments; as a minimum, the FWD load plate should be 1.2 radial meters (4 radial feet) away from any instrumentation, borehole or test pit except for the mid-panel test on the slab with instrumentation.

Typically, FWD testing for flexible pavements takes 1.0 to 1.5 h to complete, while rigid pavements take approximately 1.5 to 2 h. For flexible pavements, the test cycle is repeated a minimum of four times per test day, at 1.5- to 2.0 h intervals. The test cycle for rigid pavements is repeated a minimum of three times per test day, at 2.0- to 2.5-h intervals. Where possible, additional FWD test cycles per day to cover a 12- to 24-h time span should be conducted for both pavements types. Also, when feasible, the day's test program should start 0.5 h before sunrise.

Each test section included in the core experiment is tested on a 2-year cycle; e.g., testing in years 1, 3, 5, etc. or 2, 4, 6, etc. In non-frost areas, a uniform test frequency is used throughout the year. As a minimum, deflection testing and related data collection is repeated on a monthly basis (12 test days per year). In frost areas, the monitoring program is repeated at least twice a month during the thaw and recovery period (first 2 months of spring), and on a monthly basis for the remainder of the year (14 test days per year). More frequent monitoring is encouraged where possible for all sites in this experiment, regardless of the moisture-temperature regime.

Finally, all test locations on each pavement section must be referenced so tests can be performed ideally within  $\pm 25$  mm (1 in) of the same locations. As a minimum, reference markings must last at least 2 years, or be renewed periodically over a 2-year time span. For flexible pavements, PK nails driven into the pavement shoulder and adjacent lane, flush with the pavement surface are recommended. For rigid pavements, durable markings or nails on the shoulder and adjacent lane are recommended. Accurate measurement and records of lateral location relative to these markings is critical. (Note: under no condition should paint or holes be used inside the section limits for marking test points; use lumber crayon or chalk).

### Supplemental Studies

Deflection data for supplemental sections is collected using highway agency forces and FWD's. Successful completion of an FWD calibration process equivalent (as judged by FHWA-LTPP Division staff) to that implemented in the SHRP calibration centers is required for participation in the seasonal monitoring program. In addition, the following guidelines must be met:

- Deflection testing must conform to the LTPP standard drop sequence and sensor configurations; Manual for FWD Testing in the LTPP Study, Version 2.0, April 1993 (referred to from here on as the LTPP FWD Field Manual).
- The FWD test pattern used must conform with that established for the core experiment sections (see figures III-1 through III-3).
- A minimum of one complete FWD test cycle per test day is required for all supplemental sections, but additional test cycles are encouraged.
- The minimum annual monitoring frequency must conform with that established for the core experiment; i.e., monthly (every other year) for pavements in non-frost areas and 14 times per year for pavements in frost areas. As with the core experiment, more frequent testing is encouraged.

## *RELATED DATA*

### Core Experiment

Several ancillary data elements are collected in conjunction with the FWD testing. They include: FWD pavement surface and air temperature, manual surface layer temperature profile, moisture profiles, automated temperature profiles, depth of frost/thaw, depth to ground water table, ambient air temperature and precipitation, joint openings and joint faulting. These data elements and their collection are summarized below.

#### FWD Pavement Surface and Air Temperature

Monitoring of pavement surface and air temperature with the FWD is required. Ordinarily, automatic sensors on LTPP FWD's are used. Should the sensors be inoperable, manual measurements must be taken at intervals of 0.5 h or less. (Note: no data sheets are provided for recording pavement surface and air temperature as these data are stored in the FWD data files).

#### Manual Surface Layer Temperature Profile

Manual surface layer temperature measurements at three depths are required. These measurements should be made according to the procedures specified in the LTPP Manual for FWD Testing; data sheet for recording the temperatures is also provided in that document.

#### Moisture Profiles

Subsurface moisture profile measurements for unbound base, subbase, and subgrade layers are required at all core experiment sites. These measurements are made using TDR probes

permanently installed at the site. Readings are taken at the start of the test day and at 4-h intervals thereafter using the mobile recording unit; a minimum of two sets of readings are required per day. In case equipment for automatically recording TDR traces does not function properly, one set of manual measurements must be taken using the chart recorder option on the Tektronix 1502B cable reader. Results of manual measurements are recorded on Data Sheet SMP-D01. Printed traces generated by the cable reader, labeled with test date and sensor number, are also attached to Data Sheet SMP-D01.

### Automated Temperature Profiles

Temperature profile measurements (automatically recorded) for the entire pavement structure — surface, base, subbase and subgrade layers — are required for all core experiment sites. These measurements are made using a thermistor probe permanently installed at the site. Subsurface temperature readings are taken continuously throughout the year and stored by a datalogger permanently installed at the site. Measurements are taken at 1-min intervals; however, only daily temperature statistics (mean, minimum and maximum, time of minimum and maximum temperatures) for all thermistors and average hourly temperature for thermistors 1 through 5 are permanently stored in the datalogger. In case the equipment for automatically recording temperature does not function properly, manual measurements are taken at 1-h intervals throughout the test day using the RD100 or RD200 temperature readout units and recorded on Data Sheet SMP-D02.

### Depth of Frost/Thaw

Measurements for frost and thaw depth determination are required for all core experiment sites located in frost areas. An electric resistivity probe permanently installed at a site is used for these measurements. Frost/thaw depth (electrical resistance and resistivity) readings are taken automatically at the start of the test day and at 4-h intervals thereafter using the mobile recording unit. Manual readings are required a minimum of once per day, preferably in conjunction with the rod and level surveys (discussed later in document). Manual contact resistance and four-point resistivity measurements are recorded on Data Sheets SMP-D03 and -D04, respectively. Comments noted on these sheets should include general weather conditions, core hole condition, deviations from established measurement procedure(s), problems experienced with measurement equipment, and computed values for the check resistors. For manual ranging multimeters, the range setting for each reading should be recorded. In general, volts should be recorded in mV (millivolts -  $10^{-3}$  volts) and amperes in mA (milliamperes -  $10^{-3}$  A) units.

### Depth to Ground Water Table

Measurement of the ground water table depth is required at all core experiment sites at the start and end of each test day. Measurement is from top of piezometer pipe to water table,

|  |                                      |
|--|--------------------------------------|
| LTPP Seasonal Monitoring Program<br>Data Sheet SMP-D01<br>Manual Moisture Measurements | Agency Code <input type="text"/>     |
|  | LTPP Section ID <input type="text"/> |

**Required Settings:**

Dist./Division: 0.25 m  
 Phase Velocity: 0.99  
 Noise Filter: 1 average

| Probe Number | Probe Depth <sup>1</sup> (m) | Time (military):    |                                  | Time (military):    |                                  |
|--------------|------------------------------|---------------------|----------------------------------|---------------------|----------------------------------|
|              |                              | Apparent Length (m) | Dielectric Constant <sup>2</sup> | Apparent Length (m) | Dielectric Constant <sup>2</sup> |
| 1            | __ . ____                    | __ . ____           | __ . ____                        | __ . ____           | __ . ____                        |
| 2            | __ . ____                    | __ . ____           | __ . ____                        | __ . ____           | __ . ____                        |
| 3            | __ . ____                    | __ . ____           | __ . ____                        | __ . ____           | __ . ____                        |
| 4            | __ . ____                    | __ . ____           | __ . ____                        | __ . ____           | __ . ____                        |
| 5            | __ . ____                    | __ . ____           | __ . ____                        | __ . ____           | __ . ____                        |
| 6            | __ . ____                    | __ . ____           | __ . ____                        | __ . ____           | __ . ____                        |
| 7            | __ . ____                    | __ . ____           | __ . ____                        | __ . ____           | __ . ____                        |
| 8            | __ . ____                    | __ . ____           | __ . ____                        | __ . ____           | __ . ____                        |
| 9            | __ . ____                    | __ . ____           | __ . ____                        | __ . ____           | __ . ____                        |
| 10           | __ . ____                    | __ . ____           | __ . ____                        | __ . ____           | __ . ____                        |

<sup>1</sup> Distance in meters from pavement surface to TDR probe

<sup>2</sup> Dielectric constant is determined as follows:

$$\epsilon = \left[ \frac{(L_a)}{(L)(V_p)} \right]^2 = \left[ \frac{(D_2 - D_1)}{(L)(V_p)} \right]^2$$

where  $\epsilon$  = dielectric constant;  $L_a$  = apparent length of probe, m;  $L$  = actual length of probe units (= 0.203 m (8 in) for FHWA probes);  $V_p$  = phase velocity setting (= 0.99).

**ATTACH ALL TDR TRACES TO THIS DATA SHEET.**

Comments: \_\_\_\_\_

Prepared by: \_\_\_\_\_ Employer: \_\_\_\_\_

Date (dd/mm/yy):        /        /

|   |  |
|---|--|
| LTPP Seasonal Monitoring Program<br>Data Sheet SMP-D02<br>Manual Temperature Measurements | Agency Code <span style="float: right;">[ ]</span><br>LTPP Section ID <span style="float: right;">[ ]</span> |
|---|--|

Type of Instrument (RD100 or RD200): \_\_\_\_\_

| Thermistor Number | Temperature Readings (°C) |        |        |        |        |
|-------------------|---------------------------|--------|--------|--------|--------|
|                   | Start Time (military):    |        |        |        |        |
| 1                 | _____.                    | _____. | _____. | _____. | _____. |
| 2                 | _____.                    | _____. | _____. | _____. | _____. |
| 3                 | _____.                    | _____. | _____. | _____. | _____. |
| 4                 | _____.                    | _____. | _____. | _____. | _____. |
| 5                 | _____.                    | _____. | _____. | _____. | _____. |
| 6                 | _____.                    | _____. | _____. | _____. | _____. |
| 7                 | _____.                    | _____. | _____. | _____. | _____. |
| 8                 | _____.                    | _____. | _____. | _____. | _____. |
| 9                 | _____.                    | _____. | _____. | _____. | _____. |
| 10                | _____.                    | _____. | _____. | _____. | _____. |
| 11                | _____.                    | _____. | _____. | _____. | _____. |
| 12                | _____.                    | _____. | _____. | _____. | _____. |
| 13                | _____.                    | _____. | _____. | _____. | _____. |
| 14                | _____.                    | _____. | _____. | _____. | _____. |
| 15                | _____.                    | _____. | _____. | _____. | _____. |
| 16                | _____.                    | _____. | _____. | _____. | _____. |
| 17                | _____.                    | _____. | _____. | _____. | _____. |
| 18                | _____.                    | _____. | _____. | _____. | _____. |

Comments: \_\_\_\_\_  
 \_\_\_\_\_  
 \_\_\_\_\_

Prepared by: \_\_\_\_\_ Employer: \_\_\_\_\_

Date (dd/mm/yy):     /    /

|   |  |
|---|--|
| LTPP Seasonal Monitoring Program<br>Data Sheet SMP-D03<br>Contact Resistance Measurements | Agency Code <span style="float: right;">[ ]</span><br>LTPP Section ID <span style="float: right;">[ ]</span> |
|---|--|

Start Time (military): \_\_\_\_\_

| Test Position | Switch Settings |       | Voltage (ACV) |                 | Current (ACA) |                | Comments         |
|---------------|-----------------|-------|---------------|-----------------|---------------|----------------|------------------|
|               | II V1           | II V2 | Range         | Reading (Volts) | Range         | Reading (Amps) |                  |
| 1             | 1               | 2     |               | ---.---E---     |               | ---.---E---    |                  |
| 2             | 2               | 3     |               | ---.---E---     |               | ---.---E---    |                  |
| 3             | 3               | 4     |               | ---.---E---     |               | ---.---E---    |                  |
| 4             | 4               | 5     |               | ---.---E---     |               | ---.---E---    |                  |
| 5             | 5               | 6     |               | ---.---E---     |               | ---.---E---    |                  |
| 6             | 6               | 7     |               | ---.---E---     |               | ---.---E---    |                  |
| 7             | 7               | 8     |               | ---.---E---     |               | ---.---E---    |                  |
| 8             | 8               | 9     |               | ---.---E---     |               | ---.---E---    |                  |
| 9             | 9               | 10    |               | ---.---E---     |               | ---.---E---    |                  |
| 10            | 10              | 11    |               | ---.---E---     |               | ---.---E---    |                  |
| 11            | 11              | 12    |               | ---.---E---     |               | ---.---E---    |                  |
| 12            | 12              | 13    |               | ---.---E---     |               | ---.---E---    |                  |
| 13            | 13              | 14    |               | ---.---E---     |               | ---.---E---    |                  |
| 14            | 14              | 15    |               | ---.---E---     |               | ---.---E---    |                  |
| 15            | 15              | 16    |               | ---.---E---     |               | ---.---E---    |                  |
| 16            | 16              | 17    |               | ---.---E---     |               | ---.---E---    |                  |
| 17            | 17              | 18    |               | ---.---E---     |               | ---.---E---    |                  |
| 18            | 18              | 19    |               | ---.---E---     |               | ---.---E---    |                  |
| 19            | 19              | 20    |               | ---.---E---     |               | ---.---E---    |                  |
| 20            | 20              | 21    |               | ---.---E---     |               | ---.---E---    |                  |
| 21            | 21              | 22    |               | ---.---E---     |               | ---.---E---    |                  |
| 22            | 22              | 23    |               | ---.---E---     |               | ---.---E---    |                  |
| 23            | 23              | 24    |               | ---.---E---     |               | ---.---E---    |                  |
| 24            | 24              | 25    |               | ---.---E---     |               | ---.---E---    |                  |
| 25            | 25              | 26    |               | ---.---E---     |               | ---.---E---    |                  |
| 26            | 26              | 27    |               | ---.---E---     |               | ---.---E---    |                  |
| 27            | 27              | 28    |               | ---.---E---     |               | ---.---E---    |                  |
| 28            | 28              | 29    |               | ---.---E---     |               | ---.---E---    |                  |
| 29            | 29              | 30    |               | ---.---E---     |               | ---.---E---    |                  |
| 30            | 30              | 31    |               | ---.---E---     |               | ---.---E---    |                  |
| 31            | 31              | 32    |               | ---.---E---     |               | ---.---E---    |                  |
| 32            | 32              | 33    |               | ---.---E---     |               | ---.---E---    |                  |
| 33            | 33              | 34    |               | ---.---E---     |               | ---.---E---    |                  |
| 34            | 34              | 35    |               | ---.---E---     |               | ---.---E---    |                  |
| 35            | 35              | 36    |               | ---.---E---     |               | ---.---E---    |                  |
| 36            | 36              | 37    |               | ---.---E---     |               | ---.---E---    | R1 = ---.---E--- |
| 37            | 37              | 38    |               | ---.---E---     |               | ---.---E---    | R2 = ---.---E--- |
| 38            | 38              | 39    |               | ---.---E---     |               | ---.---E---    | R3 = ---.---E--- |
| 39            | 39              | 00    |               | ---.---E---     |               | ---.---E---    | R4 = ---.---E--- |

Notes: (1) Voltage and current readings are recorded using scientific notation; E refers to base 10 exponent.  
 (2)  $R = V/I$ , in ohms; measured resistances should be compared with known values.

Comments: \_\_\_\_\_

Prepared by: \_\_\_\_\_ Employer: \_\_\_\_\_

Date (dd/mm/yy): \_\_\_ / \_\_\_ / \_\_\_

**Data Sheet SMP-D03: Contact Resistance Measurements**

|   |  |
|---|--|
| LTPP Seasonal Monitoring Program<br>Data Sheet SMP-D04<br>Four-Point Resistivity Measurements | Agency Code <span style="float: right;">[ ]</span><br>LTPP Section ID <span style="float: right;">[ ]</span> |
|---|--|

Start Time (military): \_\_\_\_\_

| Test Position | Switch Settings |    |    |    | Voltage (ACV) |                 | Current (ACA) |                | Comments         |
|---------------|-----------------|----|----|----|---------------|-----------------|---------------|----------------|------------------|
|               | I1              | V1 | V2 | I2 | Range         | Reading (Volts) | Range         | Reading (Amps) |                  |
| 1             | 1               | 2  | 3  | 4  |               | E ____          |               | ____ E ____    |                  |
| 2             | 2               | 3  | 4  | 5  |               | ____ E ____     |               | ____ E ____    |                  |
| 3             | 3               | 4  | 5  | 6  |               | ____ E ____     |               | ____ E ____    |                  |
| 4             | 4               | 5  | 6  | 7  |               | ____ E ____     |               | ____ E ____    |                  |
| 5             | 5               | 6  | 7  | 8  |               | ____ E ____     |               | ____ E ____    |                  |
| 6             | 6               | 7  | 8  | 9  |               | ____ E ____     |               | ____ E ____    |                  |
| 7             | 7               | 8  | 9  | 10 |               | ____ E ____     |               | ____ E ____    |                  |
| 8             | 8               | 9  | 10 | 11 |               | ____ E ____     |               | ____ E ____    |                  |
| 9             | 9               | 10 | 11 | 12 |               | ____ E ____     |               | ____ E ____    |                  |
| 10            | 10              | 11 | 12 | 13 |               | ____ E ____     |               | ____ E ____    |                  |
| 11            | 11              | 12 | 13 | 14 |               | ____ E ____     |               | ____ E ____    |                  |
| 12            | 12              | 13 | 14 | 15 |               | ____ E ____     |               | ____ E ____    |                  |
| 13            | 13              | 14 | 15 | 16 |               | ____ E ____     |               | ____ E ____    |                  |
| 14            | 14              | 15 | 16 | 17 |               | ____ E ____     |               | ____ E ____    |                  |
| 15            | 15              | 16 | 17 | 18 |               | ____ E ____     |               | ____ E ____    |                  |
| 16            | 16              | 17 | 18 | 19 |               | ____ E ____     |               | ____ E ____    |                  |
| 17            | 17              | 18 | 19 | 20 |               | ____ E ____     |               | ____ E ____    |                  |
| 18            | 18              | 19 | 20 | 21 |               | ____ E ____     |               | ____ E ____    |                  |
| 19            | 19              | 20 | 21 | 22 |               | ____ E ____     |               | ____ E ____    |                  |
| 20            | 20              | 21 | 22 | 23 |               | ____ E ____     |               | ____ E ____    |                  |
| 21            | 21              | 22 | 23 | 24 |               | ____ E ____     |               | ____ E ____    |                  |
| 22            | 22              | 23 | 24 | 25 |               | ____ E ____     |               | ____ E ____    |                  |
| 23            | 23              | 24 | 25 | 26 |               | ____ E ____     |               | ____ E ____    |                  |
| 24            | 24              | 25 | 26 | 27 |               | ____ E ____     |               | ____ E ____    |                  |
| 25            | 25              | 26 | 27 | 28 |               | ____ E ____     |               | ____ E ____    |                  |
| 26            | 26              | 27 | 28 | 29 |               | ____ E ____     |               | ____ E ____    |                  |
| 27            | 27              | 28 | 29 | 30 |               | ____ E ____     |               | ____ E ____    |                  |
| 28            | 28              | 29 | 30 | 31 |               | ____ E ____     |               | ____ E ____    |                  |
| 29            | 29              | 30 | 31 | 32 |               | ____ E ____     |               | ____ E ____    |                  |
| 30            | 30              | 31 | 32 | 33 |               | ____ E ____     |               | ____ E ____    |                  |
| 31            | 31              | 32 | 33 | 34 |               | ____ E ____     |               | ____ E ____    |                  |
| 32            | 32              | 33 | 34 | 35 |               | ____ E ____     |               | ____ E ____    |                  |
| 33            | 33              | 34 | 35 | 36 |               | ____ E ____     |               | ____ E ____    |                  |
| 36            | 36              | 36 | 37 | 37 |               | ____ E ____     |               | ____ E ____    | R1 = ____ E ____ |
| 37            | 37              | 37 | 38 | 38 |               | ____ E ____     |               | ____ E ____    | R2 = ____ E ____ |
| 38            | 38              | 38 | 39 | 39 |               | ____ E ____     |               | ____ E ____    | R3 = ____ E ____ |
| 39            | 39              | 39 | 00 | 00 |               | ____ E ____     |               | ____ E ____    | R4 = ____ E ____ |

Notes: (1) Voltage and current readings are recorded using scientific notation; E refers to base 10 exponent.  
 (2)  $R = V/I$ , in ohms; measured resistances should be compared with known values.

Comments: \_\_\_\_\_  
 Prepared by: \_\_\_\_\_ Employer: \_\_\_\_\_  
 Date (dd/mm/yy): \_\_\_\_ / \_\_\_\_ / \_\_\_\_

**Data Sheet SMP-D04: Four-Point Resistivity Measurements**

recorded to accuracy of  $\pm 10$  mm (0.4 in). One observation piezometer is placed outside the pavement edge, midway between the first and last seasonal FWD test points; measurements are recorded on Data Sheet SMP-D05.

#### Ambient Air Temperature and Precipitation

Measurement of ambient air temperature and precipitation are required at all core experiment sites. These measurements are taken using an air temperature probe and rain gauge tipping-bucket permanently installed at the site. Readings are taken continuously throughout the year and stored on dataloggers permanently installed at the site. Temperature measurements are taken automatically at 1-min intervals, but only average hourly temperature and daily temperature statistics (mean, minimum, and maximum, and time of minimum and maximum) are permanently stored by the dataloggers. Precipitation readings are also taken automatically, but not at fixed time intervals. Rainfall is measured in 0.1 mm (0.004 in) increments (bucket tips when this calibrated level is reached, actuating a switch) and hourly and total daily precipitation is permanently stored by the dataloggers. No data sheets are provided for recording ambient air temperature and precipitation as these data are uploaded directly from the onsite datalogger to a portable computer.

#### Joint Openings (Rigid Pavements)

Precise measurement of joint opening is required for all joints tested in the core experiment (6 joints per rigid pavement section). Joint movement is monitored at each test joint (see joint load transfer locations in figures III-2 and III-3) to the nearest  $\pm 0.01$  mm ( $\pm 0.0004$  in), at 0.3, 1.8 and 3.4 m (1.0, 6.0 and 11.0 ft) from the outside pavement edge. At each lateral location, a digital caliper [with 153 mm (6 in)] range is used to measure the distance between two snap rings embedded in the slab on adjacent sides of the joint; measurements are recorded on Data Sheet SMP-D06. This procedure does not provide a direct measure of the joint opening; however, readings during hot summer days when the joints are completely closed provide a reference value by which joint openings can be accurately determined. Joint opening measurements are made immediately before or after each joint is tested with the FWD, for every test cycle. On the first cycle, three readings are recorded on each pair of snap rings to establish measurement accuracy for the procedure. The caliper should be closed after each set of readings for a joint to verify a "zero" reading; if not "zero", the reading should be repeated. The last column on Data Sheet SMP-D06 is for joint opening (saw cut width) that is entered into the FWD field program after each load transfer test.

#### Joint Faulting (Rigid Pavements)

Precise measurement of joint faulting is required for all joints tested in the core experiment (6 joints per pavement section). The procedure to follow is outlined in the LTPP Distress Identification Manual, May 1993. Faulting is measured at each joint tested (see figures

|  |                                 |
|--|---------------------------------|
| LTPP Seasonal Monitoring Program<br>Data Sheet SMP-D05<br>Ground Water Table Measurement | Agency Code [ ] [ ]             |
|  | LTPP Section ID [ ] [ ] [ ] [ ] |

Piezometer Depth (m): \_ \_ . \_ \_ \_

| Measurement Number | Time (military) | Depth to Water <sup>1,2</sup> (m) | Comments |
|--------------------|-----------------|-----------------------------------|----------|
| 1                  | _ _ . _ _ _     | _ _ . _ _ _                       |          |
| 2                  | _ _ . _ _ _     | _ _ . _ _ _                       |          |
| 3                  | _ _ . _ _ _     | _ _ . _ _ _                       |          |
| 4                  | _ _ . _ _ _     | _ _ . _ _ _                       |          |
| 5                  | _ _ . _ _ _     | _ _ . _ _ _                       |          |

<sup>1</sup> Distance from top of piezometer pipe to top of ground water table; to an accuracy of  $\pm 1$  mm (0.04 in)

<sup>2</sup> If piezometer pipe is dry, specify depth of 9.99 m

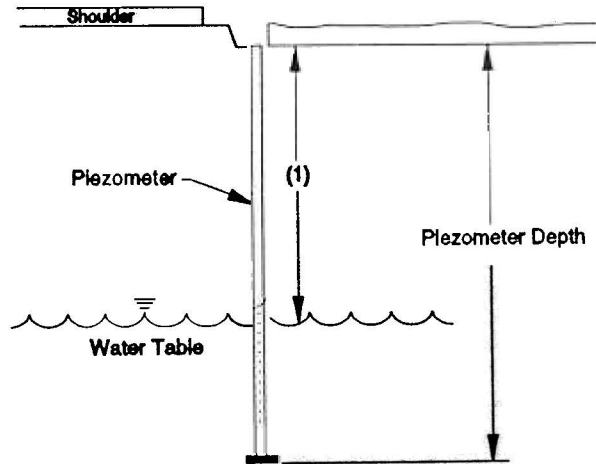

Comments: \_\_\_\_\_  
 \_\_\_\_\_  
 \_\_\_\_\_

Prepared by: \_\_\_\_\_ Employer: \_\_\_\_\_

Date (dd/mm/yy):        /        /

|   |  |
|---|--|
| LTPP Seasonal Monitoring Program<br>Data Sheet SMP-D06<br>Joint Opening Measurement | Agency Code <span style="float: right;">[ ] [ ]</span><br>LTPP Section ID <span style="float: right;">[ ] [ ] [ ] [ ]</span> |
|---|--|

| Station | Time<br>(military) | Joint Opening (mm)     |                        |                         | Joint Width<br>(mm) |
|---------|--------------------|------------------------|------------------------|-------------------------|---------------------|
|         |                    | Offset (PE):<br>_____m | Offset (ML):<br>_____m | Offset (ILE):<br>_____m |                     |
| -----   | -----              | _____.                 | _____.                 | _____.                  | ____.               |
|         |                    | _____.                 | _____.                 | _____.                  |                     |
|         |                    | _____.                 | _____.                 | _____.                  |                     |
|         |                    | _____.                 | _____.                 | _____.                  |                     |
| -----   | -----              | _____.                 | _____.                 | _____.                  | ____.               |
|         |                    | _____.                 | _____.                 | _____.                  |                     |
|         |                    | _____.                 | _____.                 | _____.                  |                     |
|         |                    | _____.                 | _____.                 | _____.                  |                     |
| -----   | -----              | _____.                 | _____.                 | _____.                  | ____.               |
|         |                    | _____.                 | _____.                 | _____.                  |                     |
|         |                    | _____.                 | _____.                 | _____.                  |                     |
|         |                    | _____.                 | _____.                 | _____.                  |                     |
| -----   | -----              | _____.                 | _____.                 | _____.                  | ____.               |
|         |                    | _____.                 | _____.                 | _____.                  |                     |
|         |                    | _____.                 | _____.                 | _____.                  |                     |
|         |                    | _____.                 | _____.                 | _____.                  |                     |
| -----   | -----              | _____.                 | _____.                 | _____.                  | ____.               |
|         |                    | _____.                 | _____.                 | _____.                  |                     |
|         |                    | _____.                 | _____.                 | _____.                  |                     |
|         |                    | _____.                 | _____.                 | _____.                  |                     |

Comments: \_\_\_\_\_

Prepared by: \_\_\_\_\_ Employer: \_\_\_\_\_

Date (dd/mm/yy): \_\_\_\_ / \_\_\_\_ / \_\_\_\_

III-2 and III-3), at 0.8, 1.8 and 2.9 m (2.5, 6.0 and 9.5 ft) from the outside pavement edge, immediately before or after each joint is tested with the FWD, once per test day. Measurements are recorded on Data Sheet SMP-D07, which does allow readings for each cycle of FWD testing.

## Supplemental Studies

The ancillary data collection requirements for the supplemental studies are very similar to those of the core experiment. The same data elements are measured for both experiments using the same instrumentation (TDR, thermistor, electrical resistivity and air temperature probes and rain gauge); however, the testing frequency and/or number of measurements may be lower. Participants are encouraged to complete the full data collection plan outlined for the core experiment.

One exception is measurement of pavement surface and air temperature. If highway agency FWD's do not automatically record these temperatures, manual readings at intervals of 30 min or less are required. If the software permits, these temperature readings should be entered into the FWD data. The readings span the time range from start to end of FWD testing.

## *ELEVATION AND PROFILE DATA*

### Core Experiment

Surface elevation and longitudinal profile are measured to obtain information related to soil volume changes due to frost heave or expansive soils. Figures III-4, III-5, and III-6 illustrate the measurement locations for flexible, jointed plain and jointed reinforced concrete pavements, respectively. Data collection activities associated with each are summarized below.

Rod and level surveys are conducted to determine changes in pavement surface elevations on all sections. The rod and level surveys are performed on four to five different occasions throughout the year depending on the temperature regime, but always concurrently with an FWD test day. In non-frost areas, one survey per season is conducted (four surveys per year), preferably in the middle of each season. A similar schedule is used in frost areas (one survey per season, at mid-season), except one additional survey is performed during late winter (fully frozen condition or time of deepest frost penetration).

Only one set of surface elevation surveys is required per test day for both flexible and rigid pavements. Elevation measurements for flexible pavements are obtained at the same stations as FWD tests. Inside the test section, elevations are measured at five offset locations: pavement edge, outside wheel path, mid-lane, inside wheel path, and inside lane edge.

|  |  |
|--|--|
| LTPP Seasonal Monitoring Program<br>Data Sheet SMP-D07<br>Joint Faulting Measurement | Agency Code <span style="float: right;">[ ]</span><br>LTPP Section ID <span style="float: right;">[ ]</span> |
|--|--|

| Station | Time<br>(military) | Joint Faulting (mm)     |                        |                         |
|---------|--------------------|-------------------------|------------------------|-------------------------|
|         |                    | Offset (OWP):<br>_____m | Offset (ML):<br>_____m | Offset (IWP):<br>_____m |
| -----   | -----              | _____.                  | _____.                 | _____.                  |
|         | -----              | _____.                  | _____.                 | _____.                  |
|         | -----              | _____.                  | _____.                 | _____.                  |
| -----   | -----              | _____.                  | _____.                 | _____.                  |
|         | -----              | _____.                  | _____.                 | _____.                  |
|         | -----              | _____.                  | _____.                 | _____.                  |
| -----   | -----              | _____.                  | _____.                 | _____.                  |
|         | -----              | _____.                  | _____.                 | _____.                  |
|         | -----              | _____.                  | _____.                 | _____.                  |
| -----   | -----              | _____.                  | _____.                 | _____.                  |
|         | -----              | _____.                  | _____.                 | _____.                  |
|         | -----              | _____.                  | _____.                 | _____.                  |

Comments: \_\_\_\_\_

\_\_\_\_\_

Prepared by: \_\_\_\_\_ Employer: \_\_\_\_\_

Date (dd/mm/yy): \_\_ / \_\_ /

**Data Sheet SMP-D07: Joint Faulting Measurements**

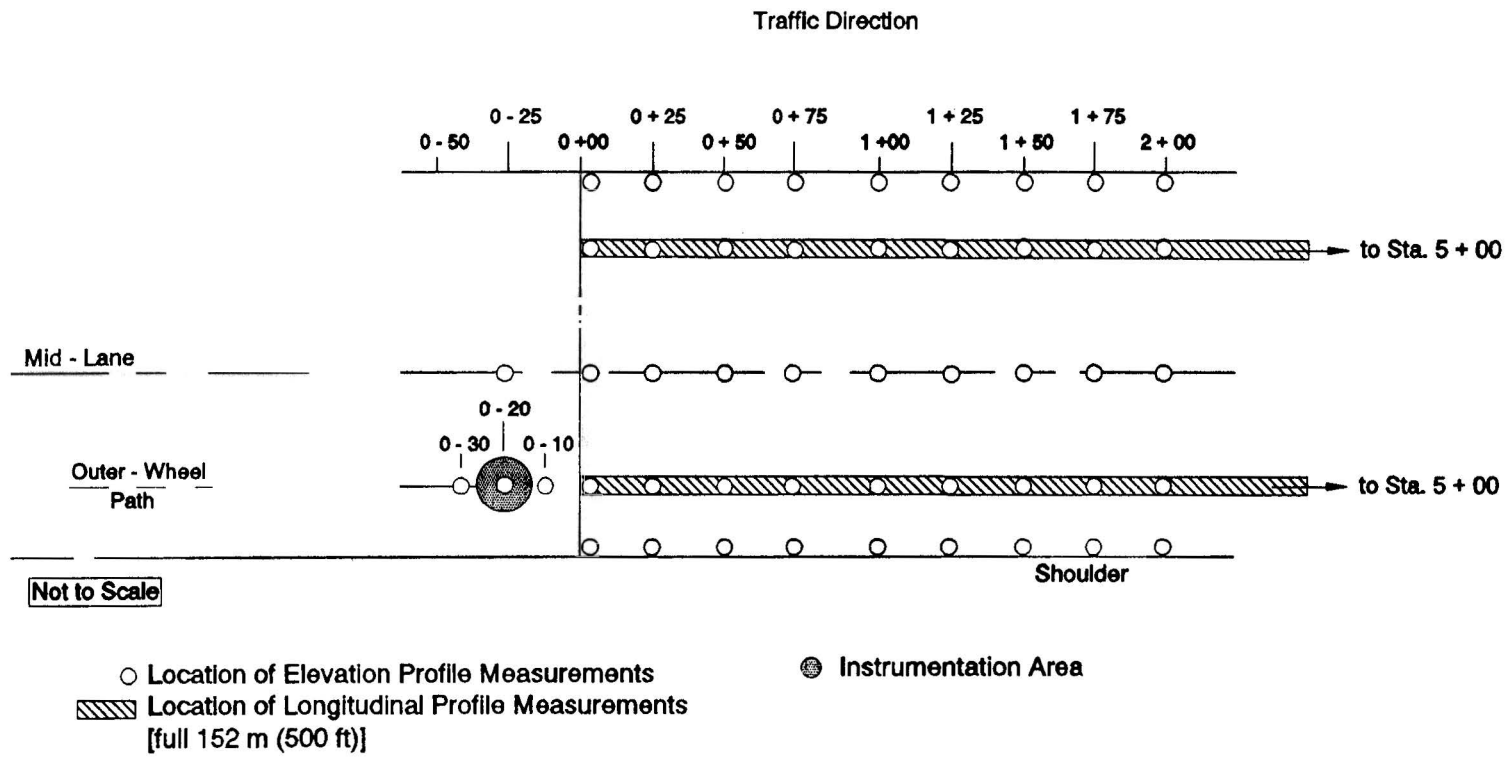

**Note:** End of section can be used instead of beginning portion; e.g., test section between stations 3 + 0 and 5 + 00 and instrumentation at appropriate station 5 + 20.

**Figure III-4 - Elevation and Profile Data Collection Plan - AC Pavements**

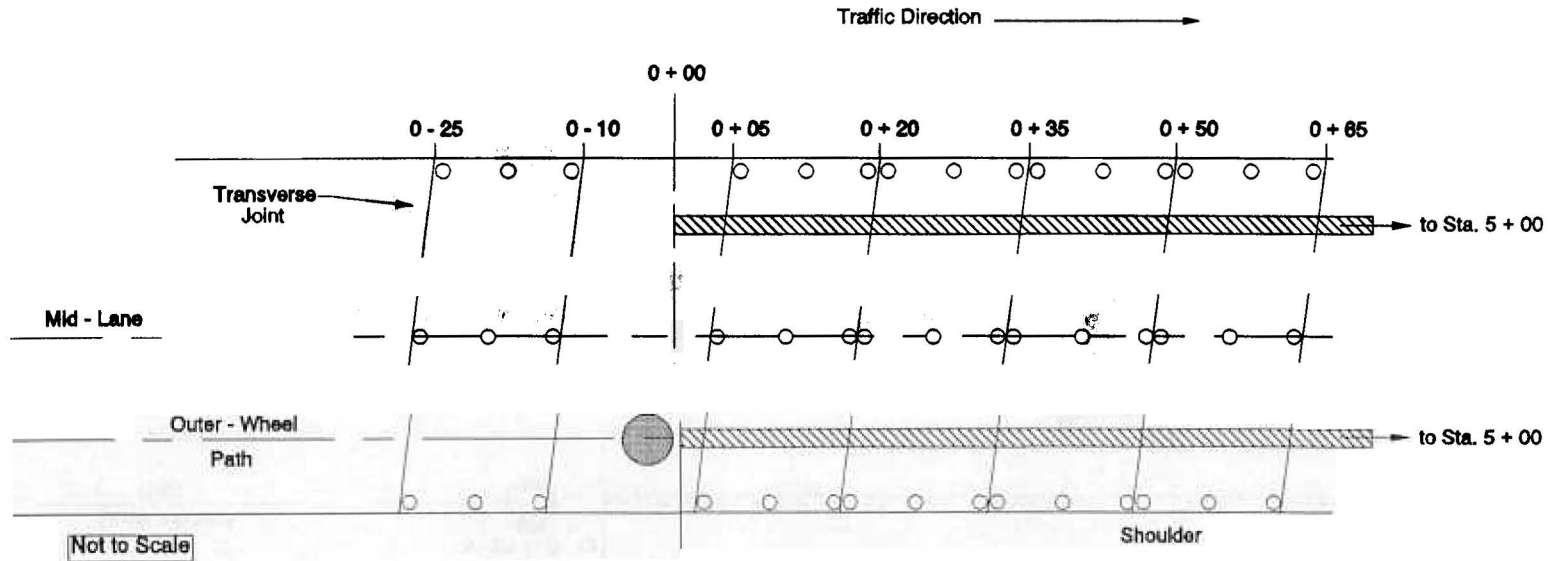

- Location of Elevation Measurements
- Instrumentation Area
- ▨ Location of Longitudinal Profile Measurements [full 152 m (500 ft)]

**Notes:** (1) End of section can be used instead of beginning portion; e.g., test section between stations 4 + 40 and 5 + 00 and instrumentation at station 5 + 15.  
 (2) Above layout assumes 4.5-m (15-ft) slab length. Distances will vary with different slab lengths.

**Figure III-5 - Elevation and Profile Data Collection Plan - JPC Pavements**

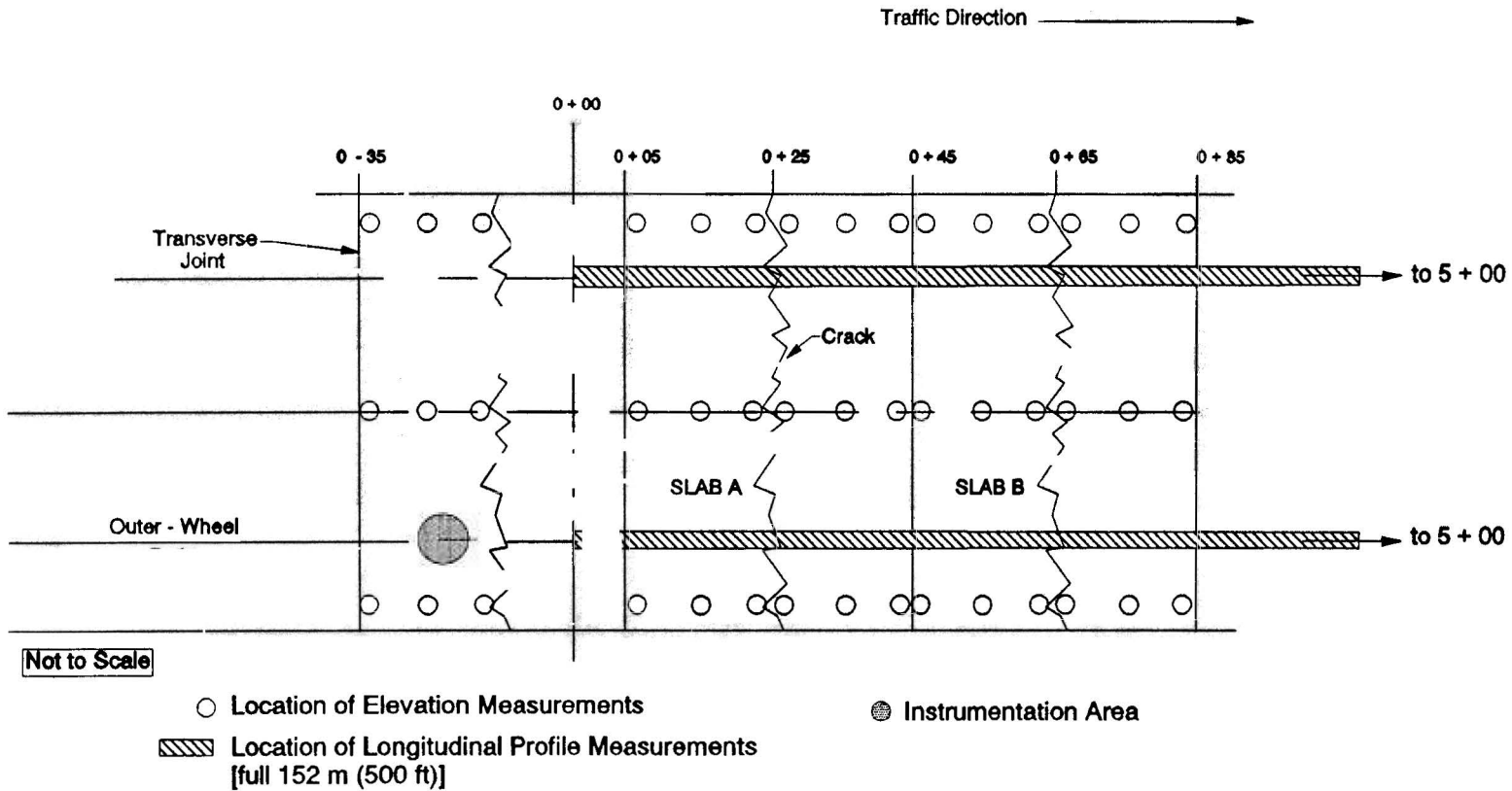

- Notes:** (1) End of section can be used instead of beginning portion; e.g., test section between stations 3 + 40 and 5 + 00 and instrumentation at station 5 + 20.  
 (2) Above layout assumes 12.2-m (40-ft) slab length. Distances will vary with different slab lengths.

**Figure III-6 - Elevation and Profile Data Collection Plan - JRC Pavements**

Measurements at the pavement edge should be located close [less than 153 mm (6 in)] to the inside edge of the painted shoulder stripe. The outside wheel path and mid-lane offsets should be at the same locations as FWD test points. Measurements at the inside lane edge should be close [less than 153 mm (6 in)] to the lane separation stripe. Offsets near the instrumentation area are the same as FWD test points, with an additional measurement at the center of the instrumentation hole. Measurements are recorded on Data Sheet SMP-D08. In the case of rigid pavements, surface elevations are measured at 9 locations on each of the five slabs tested with the FWD (i.e., a total of 45 measurements). These measurements are taken at the following longitudinal locations: beginning and ending of slab and at slab center. The offset locations are 0.3 m (1 ft) from pavement edge, mid-lane and 0.3 m (1 ft) from inside lane edge — the edge reference is the lane-shoulder interface on a normal paving lane [usually 3.7 m (12 ft) wide lane] and the outside edge of the painted shoulder stripe on a wide paving lane [usually 4.0 m (13 ft) wide lane or greater]. If the outside edge of the painted shoulder stripe is over 152 mm (6 in) inside the lane-shoulder interface, then use the outside edge of the painted shoulder stripe as the edge reference. If the lane-shoulder interface is inside the painted shoulder stripe, the interface should be used as the edge reference. (Note: six of the nine measurements are taken on top of the snap rings installed at the joints). Measurements are recorded on Data Sheet SMP-D09.

The exact longitudinal and transverse location for rod and level measurement must be referenced and documented to allow repeat measurements within 25 mm (1 in). The same alternatives proposed for marking FWD test points are recommended for the elevation surveys. Under no condition should paint or holes be used inside the section limits for marking test points. Also, all rod and level measurements must be referenced to a frost- and/or swell-free bench mark.

In addition to surface elevation surveys, profiler readings are taken at each core experiment site to measure the longitudinal profile at intervals throughout the year. Longitudinal profile surveys are conducted four times per test year for each site in non-frost areas; one survey per season, preferably in the middle of the season. In frost areas, these surveys are performed on five different occasions; one survey during the middle of each season and one additional survey during late winter (fully frozen condition).

The profiler surveys are conducted with LTPP profilers following test procedures outlined by LTPP; however, additional test cycles per day are recommended for rigid pavements to look at daily profile changes. It is not necessary to collect readings on the same day as FWD testing, but every effort should be made to minimize the time between FWD and profilometer surveys. For sites in frost areas, the late winter survey must be done within 1 week of corresponding FWD testing. The Dipstick® profiler can be used when it is not practical to schedule the LTPP profiler. In such cases, both wheel paths are surveyed over the entire length of the test section following procedures outlined in the LTPP Manual for Profile Measurements.





## Supplemental Studies

It is desirable for highway agencies to collect the same amount of elevation and profile data as in the core experiment; however, this may not be feasible. Accordingly, the following guidelines are provided:

- At least one surface elevation survey per test year in non-frost areas (during summer months) and two in frost areas (during late winter and mid-fall) is highly desirable.
- At least one longitudinal profile survey per year. Where possible, the LTPP profilometers will do this as part of routine monitoring.

## *DISTRESS SURVEYS*

### Core Experiment

Photographic distress surveys are conducted as part of the LTPP monitoring activities. In addition, two manual distress survey per year are done, one in summer and the other in winter or spring, but always concurrent with a FWD test day or other LTPP seasonal activity. These surveys must be done by accredited LTPP distress raters over the entire length of the LTPP section in accordance to the guidelines provided in the 1993 LTPP Distress Identification Manual.

### Supplemental Studies

Distress data for supplemental studies is essentially the same as that for the core experiment — photographic distress surveys or, if the site is not readily accessible to photographic survey equipment, a manual distress survey. Semi-annual distress surveys are not required, but they are encouraged.

## *SYNTHESIS OF DATA COLLECTION ACTIVITIES AND REQUIREMENTS*

A summary of the required data collection activities for the seasonal monitoring program is provided in tables III-1 through III-8, for the various combinations of experiment type (core versus supplemental), pavement type (flexible versus rigid), and temperature regime (frost versus non-frost areas). Each core site will be tested on a two year cycle; e.g., years 1, 3, 5, etc. or years 2, 4, 6, etc. Continuous monitoring (every year) of supplemental sections is encouraged.

The information provided below outlines procedures for data collection when visiting seasonal sites. Activities are listed in the suggested order for completion. Modifications

Table III-1 - Data Collection Activities: Core Experiment - Flexible Pavements (Frost Areas)

| Data Collection Activity     |   | Number of Test Points/Locations | Daily Test Frequency | Annual Test Frequency |       |
|------------------------------|---|---------------------------------|----------------------|-----------------------|-------|
| Deflection Data              | Deflection Basin Tests                      | Outer-Wheel Path                | 4                    | 14                    |       |
|                              |   | Mid-Lane                        | 4                    | 14                    |       |
| Related Data                 | Pavement Surface and Air Temperature        |                                 | 4                    | 14                    |       |
|                              | Surface Layer Temperature Gradient (Manual) |                                 | 2 to 3 (1)           | hourly                | 14    |
|                              | Moisture - Depth Gradient                   |                                 | 1                    | 2 (min)               | 14    |
|                              | Temperature - Depth Gradient (MRC)          |                                 | 1                    | (2)                   | (2)   |
|                              | Depth of Frost/Thaw (Automated and Manual)  |                                 | 1                    | 2                     | 14    |
|                              | Ground Water Table                          |                                 | 1                    | 2                     | 14    |
|                              | Ambient Temperature and Rainfall            |                                 | 1                    | (2)                   | (2)   |
| Elevation and Roughness Data | Elevation Surveys                           |                                 | 5 lines              | 1                     | 5     |
|                              | Longitudinal Profile Surveys                |                                 | 2 lines              | 1                     | 5     |
| Distress Data                | Distress Surveys                            |                                 | 1                    | 1                     | 3 (3) |

- NOTES:
- (1) Three holes required, unless surface is less than 76 mm (3 in).
  - (2) Continuous monitoring throughout the year.
  - (3) One photographic survey and two manual surveys per year.



**Table III-2 - Data Collection Activities: Core Experiment - Flexible Pavements (Non-Frost Areas)**

| Data Collection Activity     |                        | Number of Test Points/Locations             | Daily Test Frequency | Annual Test Frequency |       |
|------------------------------|------------------------|---|----------------------|-----------------------|-------|
| Deflection Data              | Deflection Basin Tests | Outer-Wheel Path                            | 11                   | 4                     | 12    |
|                              |                        | Mid-Lane                                    | 10                   | 4                     | 12    |
| Related Data                 |                        | Pavement Surface and Air Temperature        | 21                   | 4                     | 12    |
|                              |                        | Surface Layer Temperature Gradient (Manual) | 2 to 3 (1)           | hourly                | 12    |
|                              |                        | Moisture - Depth Gradient                   | 1                    | 2 (min)               | 12    |
|                              |                        | Temperature - Depth Gradient (MRC)          | 1                    | (2)                   | (2)   |
|                              |                        | Ground Water Table                          | 1                    | 2                     | 12    |
|                              |                        | Ambient Temperature and Rainfall            | 1                    | (2)                   | (2)   |
| Elevation and Roughness Data |                        | Elevation Surveys                           | 5 lines              | 1                     | 4     |
|                              |                        | Longitudinal Profile Surveys                | 2 lines              | 1                     | 4     |
| Distress Data                |                        | Distress Surveys                            | 1                    | 1                     | 3 (3) |

- NOTES:
- (1) Three holes required, unless surface is less than 76 mm (3 in).
  - (2) Continuous monitoring throughout the year.
  - (3) One photographic survey and two manual surveys per year.

| Data Collection Activity     |   | Number of Test Points/Locations | Daily Test Frequency | Annual Test Frequency |       |
|------------------------------|---|---------------------------------|----------------------|-----------------------|-------|
| Deflection Data              | Deflection Basin Tests                      | Mid-Slab                        | 5                    | 3                     | 14    |
|                              |   | Edge                            | 9                    | 3                     | 14    |
|                              | Joint Load Transfer Tests                   | Approach, Outer-Wheel Path      | 6                    | 3                     | 14    |
|                              |   | Leave, Outer-Wheel Path         | 6                    | 3                     | 14    |
| Related Data                 | Pavement Surface and Air Temperature        |                                 | 26                   | 3                     | 14    |
|                              | Surface Layer Temperature Gradient (Manual) |                                 | 3                    | hourly                | 14    |
|                              | Moisture - Depth Gradient                   |                                 | 1                    | 2 (min)               | 14    |
|                              | Temperature - Depth Gradient (MRC)          |                                 | 1                    | (1)                   | (1)   |
|                              | Depth of Frost/Thaw (Automated and Manual)  |                                 | 1                    | 2                     | 14    |
|                              | Ground Water Table                          |                                 | 1                    | 2                     | 14    |
|                              | Ambient Temperature and Rainfall            |                                 | 1                    | (1)                   | (1)   |
|                              | Joint Opening                               |                                 | 6                    | 3                     | 14    |
|                              | Joint Faulting                              |                                 | 6                    | 1                     | 14    |
| Elevation and Roughness Data | Elevation Surveys                           |                                 | 9/slab               | 1                     | 5     |
|                              | Longitudinal Profile Surveys                |                                 | 2 lines              | 1                     | 5     |
| Distress Data                | Distress Surveys                            |                                 | 1                    | 1                     | 3 (2) |

- (1) Continuous monitoring throughout the year.  
(2) One photographic survey and two manual surveys per year.

Table III-4 - Data Collection Activities: Core Experiment - Rigid Pavements (Non-Frost Areas)

| Data Collection Activity     |   | Number of Test Points/Locations | Daily Test Frequency | Annual Test Frequency |       |
|------------------------------|---|---------------------------------|----------------------|-----------------------|-------|
| Deflection Data              | Deflection Basin Tests                      | Mid-Slab                        | 5                    | 3                     | 12    |
|                              |   | Edge                            | 9                    | 3                     | 12    |
|                              | Joint Load Transfer Tests                   | Approach, Outer-Wheel Path      | 6                    | 3                     | 12    |
|                              |   | Leave, Outer-Wheel Path         | 6                    | 3                     | 12    |
| Related Data                 | Pavement Surface and Air Temperature        |                                 | 26                   | 1                     | 12    |
|                              | Surface Layer Temperature Gradient (Manual) |                                 | 3                    | hourly                | 12    |
|                              | Moisture - Depth Gradient                   |                                 | 1                    | 2 (min)               | 12    |
|                              | Temperature - Depth Gradient (MRC)          |                                 | 1                    | (1)                   | (1)   |
|                              | Ground Water Table                          |                                 | 1                    | 2                     | 12    |
|                              | Ambient Temperature and Rainfall            |                                 | 1                    | (1)                   | (1)   |
|                              | Joint Opening                               |                                 | 6                    | 3                     | 12    |
|                              | Joint Faulting                              |                                 | 6                    | 1                     | 12    |
| Elevation and Roughness Data | Elevation Surveys                           |                                 | 9/slab               | 1                     | 4     |
|                              | Longitudinal Profile Surveys                |                                 | 2 lines              | 1                     | 4     |
| Distress Data                | Distress Surveys                            |                                 | 1                    | 1                     | 3 (2) |

- NOTES:
- (1) Continuous monitoring throughout the year.
  - (2) One photographic survey and two manual surveys per year.

Table III-5 - Data Collection Activities: Supplemental Studies - Flexible Pavements (Frost Areas)

| Data Collection Activity     |   | Number of Test Points/Locations | Daily Test Frequency | Annual Test Frequency |
|------------------------------|---|---------------------------------|----------------------|-----------------------|
| Deflection Data              | Deflection Basin Tests                      | Outer-Wheel Path                | 1                    | 12                    |
|                              |   | Mid-Lane                        | 1                    | 14                    |
| Related Data                 | Pavement Surface and Air Temperature        |                                 | 1                    | 12                    |
|                              | Surface Layer Temperature Gradient (Manual) |                                 | 2 to 3 (1)           | hourly                |
|                              | Moisture - Depth Gradient                   |                                 | 1                    | 1 (min)               |
|                              | Temperature - Depth Gradient (MRC)          |                                 | 1                    | (2)                   |
|                              | Depth of Frost/Thaw (Automated)             |                                 | 1                    | 1                     |
|                              | Ground Water Table                          |                                 | 1                    | 1                     |
|                              | Ambient Temperature and Rainfall            |                                 | 1                    | (2)                   |
| Elevation and Roughness Data | Elevation Surveys                           |                                 | 5 lines              | 1                     |
|                              | Longitudinal Profile Surveys                |                                 | 2 lines              | 1                     |
| Distress Data                | Distress Surveys                            |                                 | 1                    | 1                     |
|                              |   |                                 |                      | 3 (3)                 |

- NOTES:
- (1) Three holes required, unless surface is less than 76 mm (3 in).
  - (2) Continuous monitoring throughout the year.
  - (3) One photographic survey and two manual surveys per year.

**Table III-6 - Data Collection Activities: Supplemental Studies - Flexible Pavements (Non-Frost Areas)**

| Data Collection Activity     |                        | Number of Test Points/Locations             | Daily Test Frequency | Annual Test Frequency |       |
|------------------------------|------------------------|---|----------------------|-----------------------|-------|
| Deflection Data              | Deflection Basin Tests | Outer-Wheel Path                            | 11                   | 1                     | 12    |
|                              |                        | Mid-Lane                                    | 10                   | 1                     | 14    |
| Related Data                 |                        | Pavement Surface and Air Temperature        | 21                   | 1                     | 12    |
|                              |                        | Surface Layer Temperature Gradient (Manual) | 2 to 3 (1)           | hourly                | 12    |
|                              |                        | Moisture - Depth Gradient                   | 1                    | 1 (min)               | 12    |
|                              |                        | Temperature - Depth Gradient (MRC)          | 1                    | (2)                   | (2)   |
|                              |                        | Ground Water Table                          | 1                    | 1                     | 12    |
|                              |                        | Ambient Temperature and Rainfall            | 1                    | (2)                   | (2)   |
| Elevation and Roughness Data |                        | Elevation Surveys                           | 5 lines              | 1                     | 1     |
|                              |                        | Longitudinal Profile Surveys                | 2 lines              | 1                     | 1     |
| Distress Data                |                        | Distress Surveys                            | 1                    | 1                     | 3 (3) |

- NOTES:
- (1) Three holes required, unless surface is less than 76 mm (3 in).
  - (2) Continuous monitoring throughout the year.
  - (3) One photographic survey and two manual surveys per year.

Table III-7 - Data Collection Activities: Supplemental Studies - Rigid Pavements (Frost Areas)

| Data Collection Activity     |   | Number of Test Points/Locations | Daily Test Frequency | Annual Test Frequency |       |
|------------------------------|---|---------------------------------|----------------------|-----------------------|-------|
| Deflection Data              | Deflection Basin Tests                      | Mid-Slab                        | 5                    | 1                     | 14    |
|                              |   | Edge                            | 9                    | 1                     | 14    |
|                              | Joint Load Transfer Tests                   | Approach, Outer-Wheel Path      | 6                    | 1                     | 14    |
|                              |   | Leave, Outer-Wheel Path         | 6                    | 1                     | 14    |
| Related Data                 | Pavement Surface and Air Temperature        |                                 | 26                   | 1                     | 14    |
|                              | Surface Layer Temperature Gradient (Manual) |                                 | 3                    | hourly                | 14    |
|                              | Moisture - Depth Gradient                   |                                 | 1                    | 1 (min)               | 14    |
|                              | Temperature - Depth Gradient (MRC)          |                                 | 1                    | (1)                   | (1)   |
|                              | Depth of Frost/Thaw (Automated)             |                                 | 1                    | 1                     | 14    |
|                              | Ground Water Table                          |                                 | 1                    | 1                     | 14    |
|                              | Ambient Temperature and Rainfall            |                                 | 1                    | (1)                   | (1)   |
|                              | Joint Opening                               |                                 | 6                    | 1                     | 14    |
|                              | Joint Faulting                              |                                 | 6                    | 1                     | 14    |
| Elevation and Roughness Data | Elevation Surveys                           |                                 | 9/slab               | 1                     | 2     |
|                              | Longitudinal Profile Surveys                |                                 | 2 lines              | 1                     | 1     |
| Distress Data                | Distress Surveys                            |                                 | 1                    | 1                     | 3 (2) |

- NOTES:
- (1) Continuous monitoring throughout the year.
  - (2) One photographic survey and two manual surveys per year.

**Table III-8 - Data Collection Activities: Supplemental Studies - Rigid Pavements (Non-Frost Areas)**

| Data Collection Activity     |   |                            | Number of Test Points/Locations | Daily Test Frequency | Annual Test Frequency |
|------------------------------|---|----------------------------|---------------------------------|----------------------|-----------------------|
| Deflection Data              | Deflection Basin Tests                      | Mid-Slab                   | 5                               | 1                    | 12                    |
|                              |   | Edge                       | 9                               | 1                    | 12                    |
|                              | Joint Load Transfer Tests                   | Approach, Outer-Wheel Path | 6                               | 1                    | 12                    |
|                              |   | Leave, Outer-Wheel Path    | 6                               | 1                    | 12                    |
| Related Data                 | Pavement Surface and Air Temperature        |                            | 26                              | 1                    | 12                    |
|                              | Surface Layer Temperature Gradient (Manual) |                            | 3                               | hourly               | 12                    |
|                              | Moisture - Depth Gradient                   |                            | 1                               | 1 (min)              | 12                    |
|                              | Temperature - Depth Gradient (MRC)          |                            | 1                               | (1)                  | (1)                   |
|                              | Ground Water Table                          |                            | 1                               | 1                    | 12                    |
|                              | Ambient Temperature and Rainfall            |                            | 1                               | (1)                  | (1)                   |
|                              | Joint Opening                               |                            | 6                               | 1                    | 12                    |
|                              | Joint Faulting                              |                            | 6                               | 1                    | 12                    |
| Elevation and Roughness Data | Elevation Surveys                           |                            | 9/slab                          | 1                    | 1                     |
|                              | Longitudinal Profile Surveys                |                            | 2 lines                         | 1                    | 1                     |
| Distress Data                | Distress Surveys                            |                            | 1                               | 1                    | 3 (2)                 |

- NOTES:
- (1) Continuous monitoring throughout the year.
  - (2) One photographic survey and two manual surveys per year.

may be required based on weather conditions, traffic control, and actual activities to be completed. The team leader for data collection activities must complete the SMP Field Activity Report — Data Sheet SMP-D10 — prior to leaving the site.

### Activities to Complete Prior to Site Arrival

- Call traffic control one day ahead to verify "on schedule." If schedule changes, call all districts affected.
- Batteries charged in the following equipment:
  - Replacement battery for ONSITE datalogger (when voltage drops below 11.4 V).
  - MOBILE unit (bi-weekly).
  - Computer for datalogger (run battery down daily and recharge completely).
  - Tektronix 1502B cable tester power supply (bi-weekly).
  - Survey instrument (monthly).
  - Function generator for electrical resistance and resistivity readings (bi-weekly).
- In cold climates, van and FWD heaters plugged in overnight if not in a heated garage.
- In cold climates, FWD heaters plugged into inverter while driving to site, but off while testing (refer to FHWA Directive Number FWD-9). Heaters should be turned on between FWD cycles. After testing, the FWD heaters should remain off until the van is plugged in at the next motel.
- Start "FWD Field Activity Report" for FWD testing.
- Start "SMP Field Activity Report" for Seasonal Monitoring activities.

### Activities at Site Prior to Start of FWD Testing

- Inspect cabinet and instrumentation for damage from weather, snow plows, vehicles, animals, etc. and make comments on "SMP Field Activity Report."

|  |                 |     |
|--|-----------------|-----|
| <b>LTPP Seasonal Monitoring Program<br/>Data Sheet SMP-D10<br/>SMP Field Activity Report</b> | Agency Code     | [ ] |
|  | LTPP Section ID | [ ] |

| Onsite Datalogger and Instrumentation |              |           |
|---------------------------------------|--------------|-----------|
| File Name - *.ONS                     |              | Comments: |
| Battery Replace                       | Yes - No     | Voltages  |
| Repairs/Calib.                        |              |           |
| Other: _____                          |              |           |
| Mobile Datalogger                     |              |           |
| File Name - *.MOB                     |              | Comments: |
| TDR/Resistance Voltages               | Sets ( _ _ ) |           |
| Other: _____                          |              |           |
| Manual Data Collection                |              |           |
| Piezometer                            | Yes - No     | Comments: |
| Resistance 2 pt.                      | Sets ( _ _ ) |           |
| Resistivity 4 pt.                     | Sets ( _ _ ) |           |
| Elevations                            | Sets ( _ _ ) |           |
| Distress Survey                       | Yes - No     |           |
| Long. Dipstick Profile                | Yes - No     |           |
| Photos or Video                       | Yes - No     |           |
| Other: _____                          |              |           |
| FWD and Associated Data               |              |           |
| FWD Testing                           | Sets ( _ _ ) | Operator: |
| JCP - Snap Rings                      | Sets ( _ _ ) |           |
| JCP - Faulting                        | Sets ( _ _ ) |           |
| Other: _____                          |              |           |

**IF REQUIRED, ATTACH SKETCHES TO THIS DATA SHEET**

Comments: \_\_\_\_\_  
 \_\_\_\_\_  
 \_\_\_\_\_

Prepared by: \_\_\_\_\_ Employer: \_\_\_\_\_  
 Date (dd/mm/yy): \_\_\_ / \_\_\_ /

- Inspect block over instrumentation for distress and make comments and/or sketches as per FHWA Directive Number SM-4.
- Record any problems with instrumentation or data acquisition on Data Sheet SMP-D10 (SMP Field Activity Report).
- Setup utility tent over the equipment cabinet if required.
- Hook up data acquisition equipment (MOBILE unit) according to the following steps.

**Warning: If there is potential for lightning, wait until electrical storm passes.**

Remove combination lock, remove cabinet door, and loosen bolt on panel door.

Setup MOBILE unit, Tektronix 1502B cable tester, and portable computer near equipment cabinet.

Hook ground strap from MOBILE unit to panel door (wing nut on bottom of panel).

Extend bundle of 10 TDR cables and 1 resistivity cable from cabinet, hook cables to appropriate connections on the MOBILE unit.

Observe recommendations on discharging potential on cables before connecting.

Careful not to over stress BNC connectors on multiplexer boards.

Slowly move cables in extremely cold weather to prevent cracking the insulation.

- Make appropriate connections between MOBILE unit and Tektronix 1502B cable tester, and pull cable tester power switch "on."
- Connect optical isolator in series with 7.6 m (25 ft) extension cable to COM1 of the portable computer.
- Initiate data collection for ONSITE and MOBILE dataloggers using the following procedure.

Hook optical isolator plug to datalogger.

Power switch must be "on" in the datalogger unit.

Go to the cr10 directory (cd CR10 <rtm>).

At the c:\cr10 prompt type "*CR10PM* <rtm>" to access the Procedure Manager for data collection from the ONSITE and/or MOBILE dataloggers.

Follow steps outlined in the users documentation for installation and operation instructions for the CR10 datalogger and menu software

Notes: (1) For MOBILE data collection, electrical resistance readings occur 1 min after down loading program, and TDR readings start 5 min after down loading program. Data sets are recorded at 4-h intervals. Required to get at least two data sets from MOBILE for each visit.

Return to MOBILE unit 5 min after initializing and monitor cable tester display to check traces for the TDR probes

- Run ONSFIELD software to check Onsite.dat file.

Check ONSITE data acquisition equipment if data anomalies are identified.

Leave computer on to check MOBILE after first readings are finished.

- Setup FWD and start buffer conditioning. Expect at least three conditioning cycles to stabilize loads in cold weather.

If the air temperature is below -10 °C, only use drop height one for first conditioning cycle to avoid exposing load cell to large spikes from cold buffers.

- Dig out piezometer and take first water level reading.

- Dig out optional Bench Marks if installed

- Run MOBFIELD software on Mobile.dat file to check TDR traces and resistance profile.

Check MOBILE data acquisition equipment if data anomalies are identified and rerun the MOBILE program.

## Activities in Conjunction with FWD

- Prepare three temperature holes for manual temperature gradient measurement.

Remove silicon plugs (retain for plugging holes between readings) and any water or ice from holes. Measure hole depths and compare with depths reported from previous testing to make sure all material is removed from the holes.

Add oil to holes if needed [only 5 mm (0.25 in) of oil needed].

- Read temperatures 15 min after holes prepared, and then at least every 60 min as long as traffic control is setup.
- Begin first cycle of FWD tests after final buffer conditioning.
- Activities to complete while running first cycle of FWD tests.

Establish all F1 and F3, or J1 and J3 locations within 10 mm (0.4 in) of location established during first monitoring following instrumentation installation. Neatly mark the locations with small "+" using caulk or keel visible on the camera monitor for checking FWD load plate location within 25-mm (1-in) tolerance.

Do not use any permanent markings inside the section limits, because it causes problems with profilometer operations.

If getting many repeat tests, make sure to keep at least one set of three tests at one location in order to evaluate the effects of extra drops or changes in the pavement structure.

Make sure to include joint width, snap ring spacing, and faulting measurements during J4/J5 pass on PCC sections by collecting data on joint just in front of tow vehicle during each cycle.

Measure out and mark locations for all elevation points not already marked at FWD locations. Mark with a small "+" using keel.

- Activities to complete after first cycle of FWD tests.

Set up equipment for reading resistance values using manual methods.

Make sure manual readings don't interfere with automatic readings that are taken 1 min after MOBILE unit is initialized and every 4 h after that.

Collect four point measurements.

Collect two point measurements.

**Hook electrical resistance probe cable back up to MOBILE unit before second auto reading occurs.**

- Read piezometer second time.
- Edit first cycle FWD data.
- Run FWD buffer warm up as needed.
- Start FWD cycle two.

Note: append to existing files from first cycle of FWD tests; end up with two files for AC and three files for PCC for the entire day.

- Activities to complete after collecting cycle two FWD data.

Shoot elevations on all control points as follows.

Shoot BM piezometer and any optional BM installed on the site both before and after all points on the test section.

Read piezometer third time.

Edit FWD cycle two data.

- Run FWD buffer warm up as needed.
- Start FWD cycle three.
- Activities to complete after collecting cycle three FWD data.

Manual distress survey if required (Two per year).

- Run FWD buffer warm up as needed.
- Start FWD cycle four for AC sections.
- Activities to complete after collecting cycle four FWD data.

Edit data from previous cycles.



- Activities to complete after collecting last cycle of FWD data while traffic control is still in-place.

Take last temperature readings and plug top inch of holes with silicon seal.

### Activities After FWD Testing Completed

- Final MOBILE data collection done any time at least 4 h after initial readings.
- Create backup files for ONSITE and MOBILE datalogger files.

Copy two files from data directory to drive a: with backup disk labeled "Copy A" for the seasonal loop as follows.

In the c:\cr10 directory type *COPY ##S?##??.\* a:* (replace # and ? with appropriate characters) <rtm> and verify two files copied.

Repeat above step with disk labeled "Copy B."

- If required, replace battery pack for ONSITE datalogger in the cabinet as follows.

**Proceed only if ONSITE data has been uploaded, renamed, and saved from the datalogger.**

Remove two screws on power supply cover and turn power switch located on ONSITE datalogger power supply "off."

Remove battery by unplugging battery and sliding pack out.

Place fully charged battery into empty power supply, plug battery cable into "INT" socket for internal battery, turn power switch "ON," replace cover, and tighten two screws on cover.

- Pack up all equipment.

Disconnect cable to MOBILE or ONSITE datalogger.

Hang cables inside cabinet so they will not short out datalogger when panel is closed. Also, make sure cables hang down so connectors do not collect water.

Pack up computer, MOBILE unit, cable reader, manual electrical resistance equipment, and table/stand.

Close cabinet panel, finger tighten bolt on panel, and fold plastic over door.

Install cabinet door, tighten two bolts, and lock (dry, re-lubed lock). Note, lock must have at least one tumbler rotated before it will stay closed.

Pack up tent if used.

- Read piezometer last time and pack granular material on top of cover.
- Check screen on rain gauge by standing on cabinet, and lifting funnel off. Remove any debris from the funnel and screen, but leave any snow or ice in place. Replace funnel.
- Backup FWD data and check completion of all forms.
- Prepare FWD and van for travel.

### *FILE NAMING AND DATA HANDLING*

The following convention is used to name FWD data files obtained as part of the seasonal monitoring program:

4 8 S E 9 3 C 1 . F W D  
1 2 3 4 5 6 7 8 9 10 11 12

where characters

- |            |   |   |
|------------|---|---|
| 1, 2       | = | agency code; e.g., "48" for Texas   |
| 3          | = | always "S" for seasonal   |
| 4          | = | seasonal site identifier within agency; e.g., "E" is the fifth seasonal site in Texas |
| 5, 6       | = | last two digits of seasonal monitoring year; e.g., "93" for 1993                      |
| 7          | = | sequential visit identifier or code; e.g., "C" for third visit of that year           |
| 8          | = | FWD pass number; e.g., "3" for outer-wheel path, etc.                                 |
| 9          | = | ."  |
| 10, 11, 12 | = | always "FWD" for FWD testing  |

For profiler data files, the naming convention is as follows:

4 8 S E 3 C . A 3 2  
 1 2 3 4 5 6 7 8 9 10

where characters

- 1, 2 = agency code; e.g., "48" for Texas
- 3 = always "S" for seasonal
- 4 = seasonal site identifier within agency; e.g., "E" is the fifth seasonal site in Texas
- 5,9 = last digit of the year; e.g., "3" for 1993
- 6 = sequential visit identifier or code; e.g., "C" for third visit of that year
- 7 = "."
- 8 = month in which data was obtained; e.g., "A" for January, "B" for February, "L" for December.
- 10 = profiler run number; e.g., "2" for run number 2 (minimum of 5 and maximum of 9 runs per visit)

And, for ONSITE and MOBILE data files, the following naming convention is used:

4 8 S B 9 3 C K . O N S  
 1 2 3 4 5 6 7 8 9 10 11 12

where characters

- 1, 2 = agency code; e.g., "48" for Texas
- 3 = always "S" for seasonal
- 4 = seasonal site identifier within agency; e.g., "B" is the second seasonal site in Texas
- 5, 6 = last two digits of the year; e.g., "93" for 1993
- 7 = sequential visit identifier or code; e.g., "C" for third visit of that year
- 8 = month on which data was uploaded; e.g., "K" for November (A for January, B for February, etc.)
- 9 =
- 10, 11, 12 = file extension; if data was obtained from the on-site dataloggers use "ONS" and, if obtained through the mobile unit use "MOB."

FWD, ONSITE, and MOBILE data files have the same first seven characters in file names for a visit on a given date. A visit is anytime data is collected or uploaded at a site (increments character 7). Profiler data files have the same first four characters for a visit on a given date, but the fifth and sixth characters are the same as the sixth and seventh

characters in the FWD, ONSITE and MOBILE data files — a character was eliminated in the profiler data file name, which only allows six characters.

Back-up copies of all seasonal data files are made prior to leaving the site. For both FWD and profiler data files, the back-up procedures specified in the respective LTPP manuals and/or subsequent directives should be used. For the ONSITE and MOBILE data files, the same back-up procedure as the FWD is used except compression of the files is not required.

Other data handling procedures for FWD and profiler data files are the same as those currently used in the LTPP program. The development of similar procedures for the ONSITE and MOBILE data are currently in progress.



**APPENDIX A**

**SEASONAL MONITORING PROGRAM DATA SHEETS**

**Calibration: SMP-C01 to SMP-C05**

**Installation: SMP-I01 to SMP-I06**

**Data Collection: SMP-D01 to SMP-D09**

## LIST OF DATA SHEETS

### Data Sheet

|                     |   |      |
|---------------------|---|------|
| Data Sheet SMP-C01: | TDR Probe Check . . . . .   | A-2  |
| Data Sheet SMP-C02: | Thermistor and Air Temperature Probe<br>Check . . . . .           | A-4  |
| Data Sheet SMP-C03: | Electrical Resistivity Probe Check . . . . .                      | A-5  |
| Data Sheet SMP-C04: | Function Generator, Multimeter, and Swith Box<br>Checks . . . . . | A-6  |
| Data Sheet SMP-C05: | Tipping-Bucket Rain Gauge Calibration . . .                       | A-7  |
| Data Sheet SMP-I01: | List of Installed Instrumentation . . . . .                       | A-8  |
| Data Sheet SMP-I02: | Instrumentation Location . . . . .                                | A-9  |
| Data Sheet SMP-I03: | Log of Piezometer Hole . . . . .                                  | A-10 |
| Data Sheet SMP-I04: | Log of Instrumentation Hole . . . . .                             | A-11 |
| Data Sheet SMP-I05: | Field Gravimetric Moisture Contents . . .                         | A-12 |
| Data Sheet SMP-I06: | TDR Moisture Contents . . . . .                                   | A-13 |
| Data Sheet SMP-D01: | Manual Moisture Measurements . . . . .                            | A-14 |
| Data Sheet SMP-D02: | Manual Temperature Measurements . . . .                           | A-15 |
| Data Sheet SMP-D03: | Contact Resistance Measurements . . . . .                         | A-16 |
| Data Sheet SMP-D04: | Four-Point Resistivity Measurements . . .                         | A-17 |
| Data Sheet SMP-D05: | Ground Water Table Measurements . . . .                           | A-18 |
| Data Sheet SMP-D06: | Joint Opening Measurements . . . . .                              | A-19 |
| Data Sheet SMP-D07: | Joint Faulting Measurements . . . . .                             | A-20 |
| Data Sheet SMP-D08: | Surface Elevation Measurements - AC<br>Pavements . . . . .        | A-21 |
| Data Sheet SMP-D09: | Surface Elevation Measurements - PCC<br>Pavements . . . . .       | A-22 |
| Data Sheet SMP-D10: | SMP Field Activity Report . . . . .                               | A-23 |

|   |  |
|---|--|
| <p>LTPP Seasonal Monitoring Program<br/>Data Sheet SMP-C01 (Page 1)<br/>TDR Probe Check</p> | <p>Agency Code <span style="float: right;">[ ]</span><br/>LTPP Section ID <span style="float: right;">[ ]</span></p> |
|---|--|

Place TDR trace "Shorted at Start" here

| TDR Trace          | Apparent Length, (m) | Dielectric Constant |
|--------------------|----------------------|---------------------|
| "Shorted at Start" | _____                | _____               |

Place TDR trace "In Air" here

| TDR Trace | Apparent Length, (m) | Dielectric Constant <sup>1</sup> |
|-----------|----------------------|----------------------------------|
| "In Air"  | _____                | _____                            |